

# FX-10GM,FX(E)-20GM

## Hardware/Programming Manual

Manual number: JY992D60401B  
Manual revision: B  
Date: Sep 1998

### Foreword

- This manual contains text, diagrams and explanations which will guide the reader in the correct installation and operation of the FX-10GM,FX(E)-20GM unit.
- Before attempting to install or use the FX-10GM,FX(E)-20GM unit this manual should be read and understood.
- If in doubt at any stage of the installation of the FX-10GM,FX(E)-20GM unit always consult a professional electrical engineer who is qualified and trained to the local and national standards which apply to the installation site.
- If in doubt about the operation or use of the FX-10GM,FX(E)-20GM unit please consult the nearest Mitsubishi Electric distributor.
- This manual is subject to change without notice.







## **Guidelines for the safety of the user and protection of the FX-10GM,FX(E)-20GM unit**

This manual provides information for the use of the FX-10GM,FX(E)-20GM unit. The manual has been written to be used by trained and competent personnel. The definition of such a person or persons is as follows;

- a) Any engineer who is responsible for the planning, design and construction of automatic equipment using the product associated with this manual should be of a competent nature,trained and qualified to the local and national standards required to fulfill that role. These engineers should be fully aware of all aspects of safety with regards to automated equipment.
- b) Any commissioning or service engineer must be of a competent nature,trained and qualified to the local and national standards required to fulfill that job. These engineers should also be trained in the use and maintenance of the completed product. This includes being completely familiar with all associated documentation for the said product. All maintenance should be carried out in accordance with established safety practices.
- c) All operators of the completed equipment should be trained to use that product in a safe and co-ordinated manner in compliance to established safety practices. The operators should also be familiar with documentation which is connected with the actual operation of the completed equipment.

Note: the term 'completed equipment' refers to a third party constructed device which contains or uses the product associated with this manual.

## **Notes on the symbology used in this manual**

At various times through out this manual certain symbols will be used to highlight points of information which are intended to ensure the users personal safety and protect the integrity of equipment. Whenever any of the following symbols are encountered its associated note must be read and understood. Each of the symbols used will now be listed with a brief description of its meaning.

### Hardware warnings



Indicates that the identified danger **WILL** cause physical and property damage.



Indicates that the identified danger could **POSSIBLY** cause physical and property damage.



Indicates a point of further interest or further explanation.

### Software warning



Indicates special care must be taken when using this element of software



Indicates a special point which the user of the associate software element should be aware of



Indicates a point of interest or further explanation

# CONTENTS

<b>1. INTRODUCTION</b> .....	<b>1-1 ~ 1-10</b>
1.1 Outline of the Unit .....	1 - 1
1.2 System Configuration of the FX-10GM .....	1 - 2
1.2.1 Nomenclature .....	1 - 2
1.2.2 System configuration and I/O assignment .....	1 - 3
1.3 System Configuration of the FX(E)-20GM .....	1 - 6
1.3.1 Nomenclature .....	1 - 6
1.3.2 System configuration and I/O assignment (during independent operation) .....	1 - 7
1.3.3 System configuration and I/O assignment (when a programmable controller is connected) .....	1 - 8
<b>2. SPECIFICATIONS AND WIRING</b> .....	<b>2-1 ~ 2-36</b>
2.1 General Specifications .....	2 - 1
2.2 Outside dimensions .....	2 - 2
2.3 Performance specifications .....	2 - 3
2.4 General installation/wiring work .....	2 - 5
2.5 Power Supply Specifications and Wiring .....	2 - 7
2.5.1 Power Supply Specifications .....	2 - 7
2.5.2 Service power supply .....	2 - 8
2.5.3 Power supply connection (FX-10GM) .....	2 - 9
2.5.4 Power supply connection (FX-20GM/E-20GM) .....	2-11
2.6 I/O Specifications and Wiring .....	2-13
2.6.1 Input specifications and external wiring .....	2-13
2.6.2 Output specifications and external wiring .....	2-18
2.6.3 Operation input wiring .....	2-21
2.6.4 Drive system/mechanical system I/O wiring .....	2-22
2.6.5 Absolute position (ABS) detection wiring .....	2-23
2.6.6 Manual pulse generator wiring .....	2-24
2.7 Optional Units .....	2-25
2.7.1 I/O cables and connectors .....	2-25
2.7.2 Motor connection cables .....	2-26
2.7.3 Terminal block .....	2-29
2.7.4 I/O extension block .....	2-35
<b>3. OPERATION, MAINTENANCE AND INSPECTION</b> .....	<b>3-1 ~ 3-22</b>
3.1 Before Starting Operation .....	3 - 2
3.2 Operation .....	3 - 3
3.2.1 Incremental/absolute drive method .....	3 - 3
3.2.2 Direction of motor rotation .....	3 - 4
3.2.3 Each signal fetch timing .....	3 - 5
3.2.4 Zero return .....	3 - 6
3.2.5 JOG operation .....	3-12
3.2.6 Single-step operation .....	3-13
3.2.7 Automatic operation .....	3-14
3.3 Troubleshooting .....	3-15
3.3.1 Troubleshooting using LEDs .....	3-15
3.4 Maintenance .....	3-18
3.5 Error Code List .....	3-19
<b>4. PARAMETERS AND SPECIAL DEVICES</b> .....	<b>4-1 ~ 4-32</b>
4.1 Notes on Parameters in General .....	4 - 1
4.2 System Parameters .....	4 - 3
4.2.1 Basic parameters .....	4 - 3
4.2.2 Subtask parameters .....	4 - 5
4.3 Positioning Parameters .....	4 - 7
4.3.1 Units .....	4 - 7
4.3.2 Speed, acceleration/deceleration, etc. ....	4 - 9
4.3.3 Machine zero return, etc. ....	4-11
4.3.4 Other settings .....	4-13
4.3.5 Default values (initial values) .....	4-16

4.4	I/O Control Parameters .....	4-17
4.4.1	Program No. ....	4-17
4.4.2	Outputting the M code to the outside .....	4-19
4.4.3	Manual pulse generator .....	4-21
4.4.4	Detecting the absolute position (ABS) .....	4-22
4.4.5	Single-step operation and general purpose input .....	4-23
4.4.6	Default values (initial values) .....	4-24
4.5	Special Devices .....	4-25
4.5.1	General description .....	4-25
4.5.2	Special auxiliary relays .....	4-27
4.5.3	Special data registers .....	4-29
<b>5.</b>	<b>POSITIONING CONTROL INSTRUCTIONS .....</b>	<b>4-1 ~ 4-30</b>
5.1	General Rules for Positioning Control Instructions .....	5 - 1
5.1.1	Program format .....	5 - 1
5.1.2	Instruction format .....	5 - 3
5.1.3	M code instruction format .....	5 - 6
5.1.4	Instruction execution time .....	5 - 7
5.2	Drive Control Instructions .....	5 - 9
5.3	Standby Instructions .....	5-17
5.4	Zero Return Control Instructions .....	5-19
5.5	Interrupt Drive Instructions .....	5-21
5.6	Compensation .....	5-25
5.7	Address Specification and Present Value Change Instruction .....	5-26
5.8	Subtasks .....	5-28
<b>6.</b>	<b>SEQUENCE CONTROL INSTRUCTIONS .....</b>	<b>6-1 ~ 6-24</b>
6.1	Applicable devices .....	6 - 1
6.2	Basic sequence instructions .....	6 - 2
6.3	General rules for application instructions .....	6 - 3
6.3.1	Application instruction format .....	6 - 3
6.3.2	Bit devices .....	6 - 5
6.3.3	Data length and instruction execution format .....	6 - 6
6.3.4	Indexing of devices .....	6 - 6
6.4	Program Flow .....	6 - 7
6.5	Comparison, Transfer, etc. ....	6-11
6.6	Arithmetic and Logical Operations .....	6-15
6.8	Other Instructions .....	6-23
<b>7.</b>	<b>Communication with Programmable Controller .....</b>	<b>7-1 ~ 7-12</b>
7.1	Outline .....	7 - 1
7.2	Buffer Memories .....	7 - 2
7.2.1	Configuration of the buffer memories .....	7 - 2
7.2.2	FROM/TO instructions .....	7 - 3
7.2.3	Assignment of buffer memories .....	7 - 4
7.3	Functions Enabled by the Programmable Controller .....	7 - 5
7.3.1	Specifying the program No. ....	7 - 5
7.3.2	Operation commands (start/stop) .....	7 - 6
7.3.3	Reading the present value .....	7 - 7
7.3.4	Setting the travel and the operation speed .....	7 - 8
7.3.5	Reading M codes .....	7 - 9
7.3.6	Reading/Changing the parameters .....	7-11
<b>8.</b>	<b>CONNECTION EXAMPLES WITH MOTOR .....</b>	<b>8-1 ~ 8-12</b>
<b>9.</b>	<b>Supplemental Items .....</b>	<b>9-1 ~ 9-14</b>
9.1	Compensation ignore function added for incremental drive .....	9 - 1
9.2	Teaching function added in AUTO mode .....	9 - 2
9.3	Positioning using the table method (FX-10GM) .....	9 - 3
9.4	M mode control during operation with multi-step speed: M9160 (FX-10GM) .....	9-15
9.5	Connection with FX2N Series PC .....	9-17
9.6	Pulse output waveform .....	9-18
	<b>For parameter recording .....</b>	<b>A-1 ~ A-2</b>



# 1. INTRODUCTION

This section explains the outline of the positioning unit and the related peripheral units.

In description, the FX-10GM may be abbreviated as "10GM", the FX-20GM and the E-20GM as "FX (E)-20GM" or "20GM".

## 1.1 Outline of the Unit

The FX-10GM/FX-20GM/E-20GM positioning unit is the pulse chain output type, and enables the positioning control of the stepping motor or the servo motor via the drive unit.

**Table:1.1**

- Each model is mainly classified as follows.

Model name	Number of control axes	Positioning languages	Number of output pulses	Interpolation control	Connection to Programmable controller
FX-10GM	1	Dedicated language	1 to 200 kPPS		Connected to FX2/FX2c or performs independently
FX-20GM	2	+	1 to 200 kPPS (100 kPPS during interpolation)	Linear interpolation and circular interpolation	
E-20GM		Sequence language			Dedicated to independent operation

Number of control axes

- FX-10GM: For one axis. FX-20GM, E-20GM: For two axes (Simultaneous 2-axis operation and independent 2-axis operation are possible.)  
\* The number of axes indicates the number of motors controlled.

Positioning languages

- Both dedicated positioning language (cod instructions) and sequence language (basic instructions and application instructions).  
The languages are compatible among the FX-10GM, the FX-20GM and the E-20GM.

Number of output pulses

- High-speed pulse output from 1 PPS to 200 kPPS maximum (100 kPPS maximum during interpolation control in the FX-20GM and the E-20GM).
- Linear interpolation and circular interpolation are available in the FX-20GM and E-20GM.

Programmable controller connected

- The FX-10GM/FX-20GM can be connected to the FX/FX<sub>2C</sub> Series programmable controller to read or write the positioning data. Each unit can also be used independently.
- To the FX-20GM/E-20GM (programmable controller) extension blocks can be connected as general purpose I/O points of the positioning unit. (Forty-eight extension I/O points can be added to the 8 input points and 8 output points already in the main unit. Sixty-four I/O points in all are possible.)

## 1.2 System Configuration of the FX-10GM

### 1.2.1 Nomenclature

This section explains the names of the terminals and the connectors provided in the FX-10GM.

**Figure:1.1**

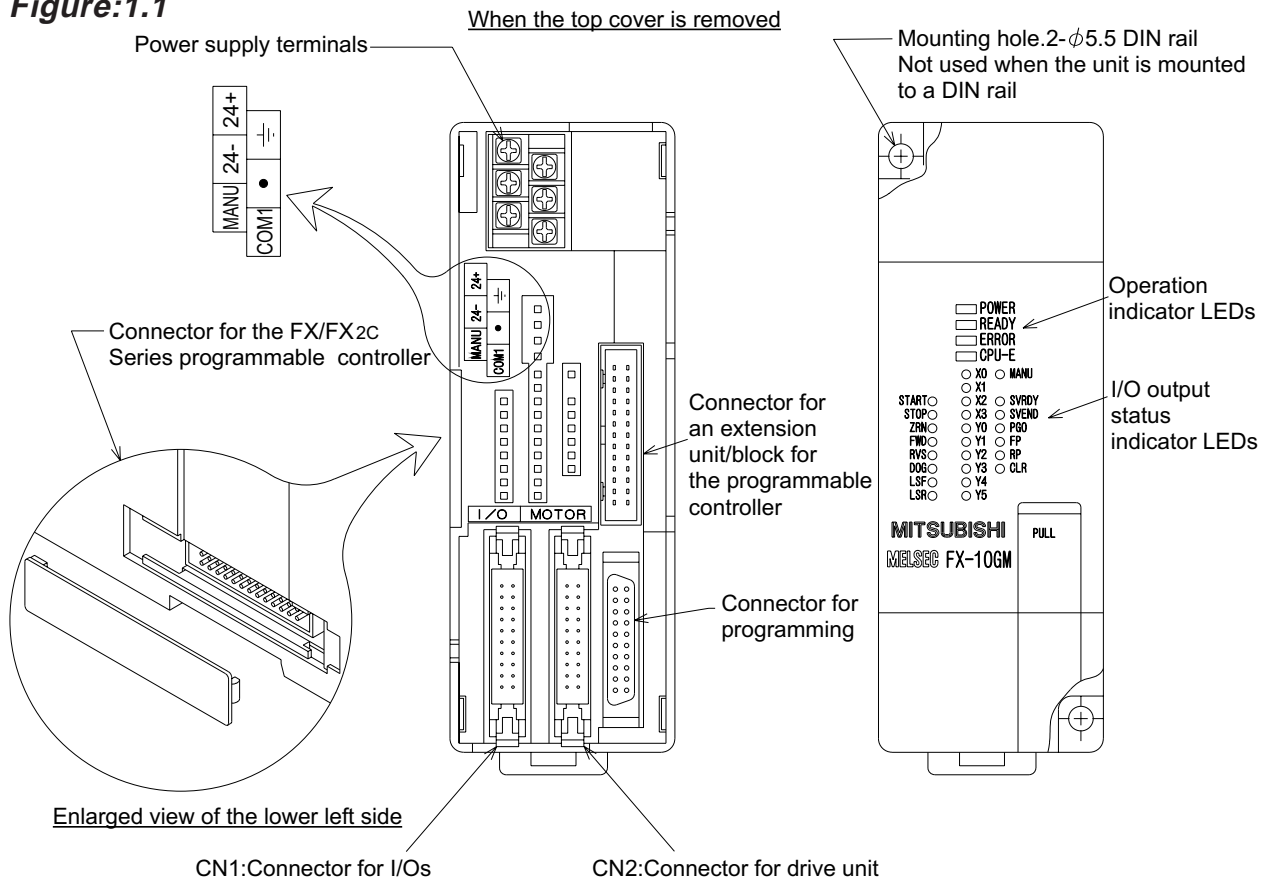

CN1: Connector for I/Os

10	Y4	COM1	LSR	LSF	DOG	RVS	FWD	ZRN	STOP	START	1
20	Y5	COM1	Y3	Y2	Y1	Y0	X3	X2	X1	X0	11

CN2: Connector for drive unit

11	SVEND	COM2	PG0	COM4	RP0	RP	24(+)	VC	COM5	ST2	20
1	SVRDY	COM2	CLR	COM3	FP0	FP	24(+)	VC	COM5	ST1	10

## 1.2.2 System configuration and I/O assignment

This section explains the system configuration and I/O assignment of the FX-10GM.

### Independent operation

- The FX-10GM can operate independently because it is equipped with a power supply of 24 VDC, CPU, operation inputs, mechanical inputs and drive unit inputs/outputs as described on the next page.
- The FX-10GM can be connected to external I/O devices because it is equipped with 4 input points (X0 to X3) and 6 output points (Y0 to Y5) as general purpose I/Os. When the I/O points are insufficient, use a programmable controller as described below.

### Connecting a programmable controller

- Applicable programmable controller: FX or FX<sub>2C</sub> Series  
The FX-10GM is treated as a special unit of the programmable controller. Eight special units (such as the analog I/O unit, the high-speed counter, etc.) including the FX-10GM can be connected to a programmable controller.

**Figure:1.2**

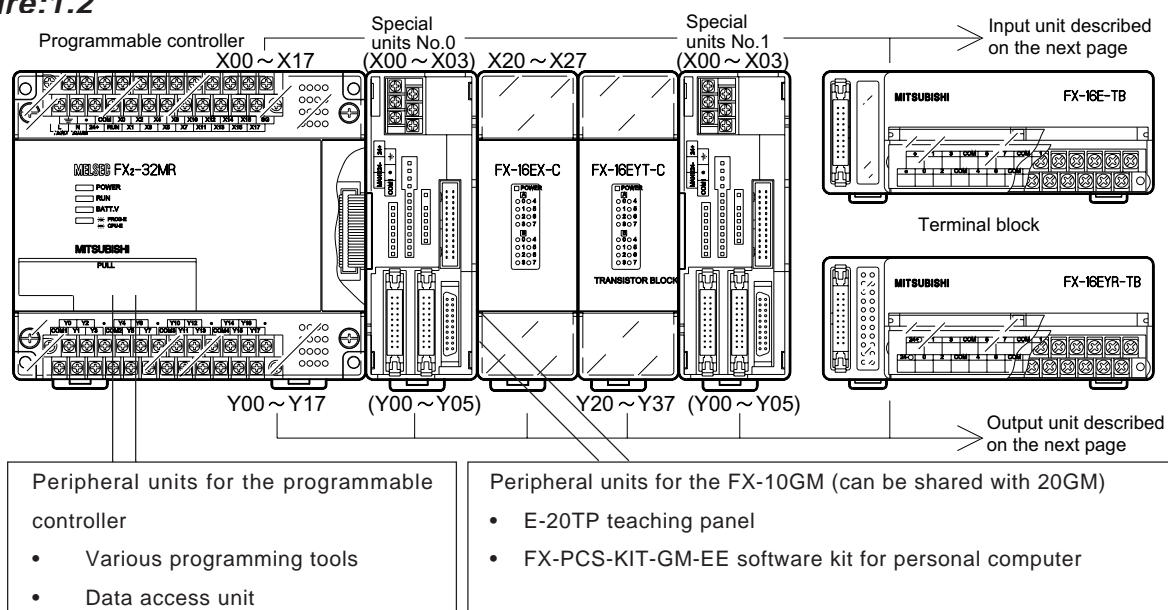

- I/O assignment  
The FX-10GM is treated as a special unit of the programmable controller. The special unit Nos. 0 to 7 are automatically assigned to each of the special units from the unit closest to the programmable controller (The No. assigned here is regarded as the unit No. specified in the FROM/TO instruction.)  
No I/Os of the programmable controller are assigned, and the general purpose I/Os of the FX-10GM are controlled by the 10GM.

For details of the I/O assignment in the programmable controller, refer to the manual of the FX/FX<sub>2C</sub> Series programmable controller. The number of extension blocks connected after the 10GM is limited. For details, refer to page 2-8.

See also service power supply: Section 2.5.2

- The optional cables are convenient for wiring the following I/O units.  
Units for general I/O connection

- For the general I/Os of the positioning unit and the extension I/Os of the programmable controller (the extension I/Os connected to the FX-20GM/E-20GM), the following external units can be connected.

Various input switches

The various input switches such as a push-button switch, limit switch, sensor, etc. can be connected.

Manual pulse generator

A pulse generator can be connected to each axis, or one pulse generator can be connected to both axes and switched between them. The manual pulse generators used must be an open collector output type.

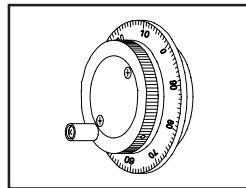

Interrupt input

The input from the manual pulse generator can be used as control input for interrupt positioning control by switching the line.

General input/extension input

Input from the digital switch

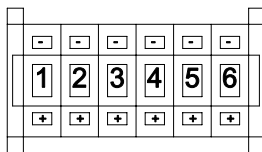

- Up to 6 digits are possible with the FX-10GM. Use with a programmable controller for more digits.

Various data settings can be fetched through connections that save wiring, either by a direct connection method or by multiplexing input/outputs.

- [1] Program No. specification: 1 to 2 digits for each axis
- [2] The following data can be set using direct specification instructions.

- Target position
- Speed
- Center coordinates of circular arc
- Radius of circular arc
- Various parameters and control constants

General output/extension output

Auxiliary equipment control output

The ON/OFF control outputs for various auxiliary equipment are generated by M code signals (2-digit BCD) or a direct program.

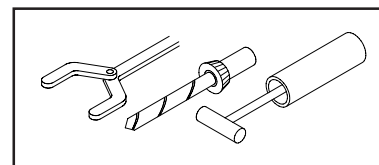

- [1] Current position display: 8 digits maximum for each axis.
- [2] The line No. being executed, the set speed, the present dwell value, various parameters and the status can be read and displayed.

Seven-segment display

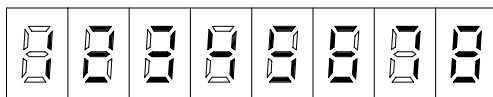

Various setting data and statuses, and present value, can be displayed through connections that save wiring, either by a direct connection method or by multiplexing outputs.

- Up to 2 digits are possible with the FX-10GM. Use with a programmable controller for more digits.

- The positioning control command inputs and the drive unit connection are enabled via dedicated I/O.

## Units for dedicated I/O connection

## Operation system inputs

- Automatic start command
- Single-step operation command
- Stop command
- System stop command (20GM)
- Zero return command
- Manual forward rotation command
- Manual reverse rotation command
- Manual/automatic selection

## Mechanical system inputs

- Forward rotation limit
- Reverse rotation limit
- Near-point dog signal

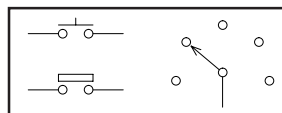

## Drive unit

- Zero point signal
  - Servo ready
  - Servo end
  - Forward/reverse rotation pulse sample
  - Clear signal
  - Absolute position detection signal
- etc.

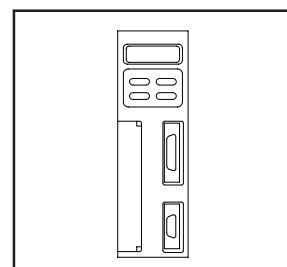

Reference wiring: Sections 2 and 8.

# 1.3 System Configuration of the FX(E)-20GM

## 1.3.1 Nomenclature

This section explains the names of the terminals and the connectors provided in the FX-20GM/E-20GM.

Figure:1.3

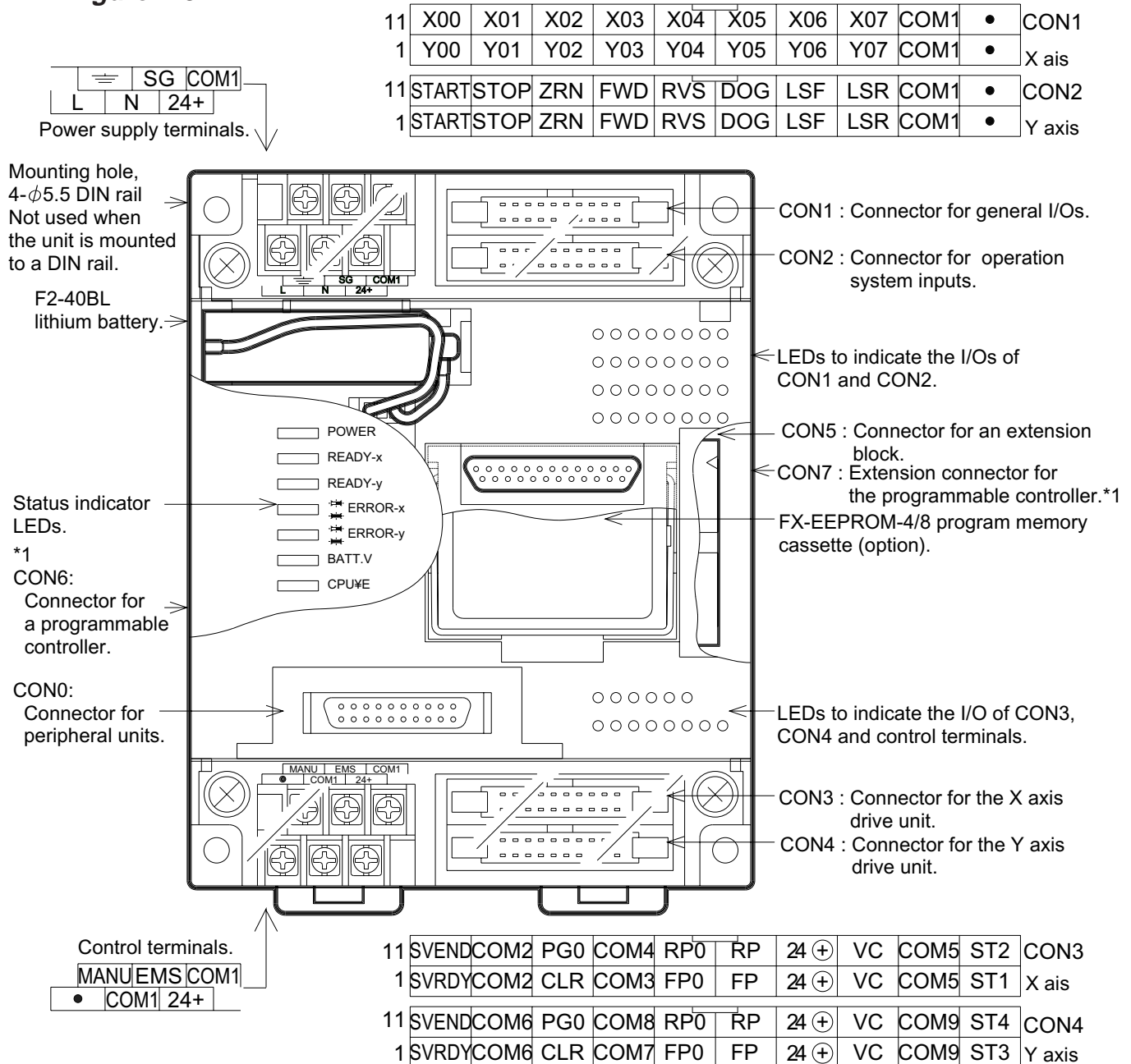

\*1 CON6 and CON7 are provided in the FX-20GM only.  
(For details, refer to Section 1.3.3.)

### 1.3.2 System configuration and I/O assignment (during independent operation)

This section explains the system configuration and an assignment example when the FX-20GM/E-20GM is used independently.

#### Independent operation

- The FX-20GM/E-20GM can operate independently because it is equipped with a power supply (100 to 200 VAC) and I/Os to connect various units.
- Eight input points (X0 to X7) and eight output points (Y0 to Y7) are provided as general I/Os on the main unit to connect external I/O devices. When I/O points are not sufficient, (programmable controller) extension blocks can be connected to CON5 as extensions of the positioning unit.

Figure:1.4

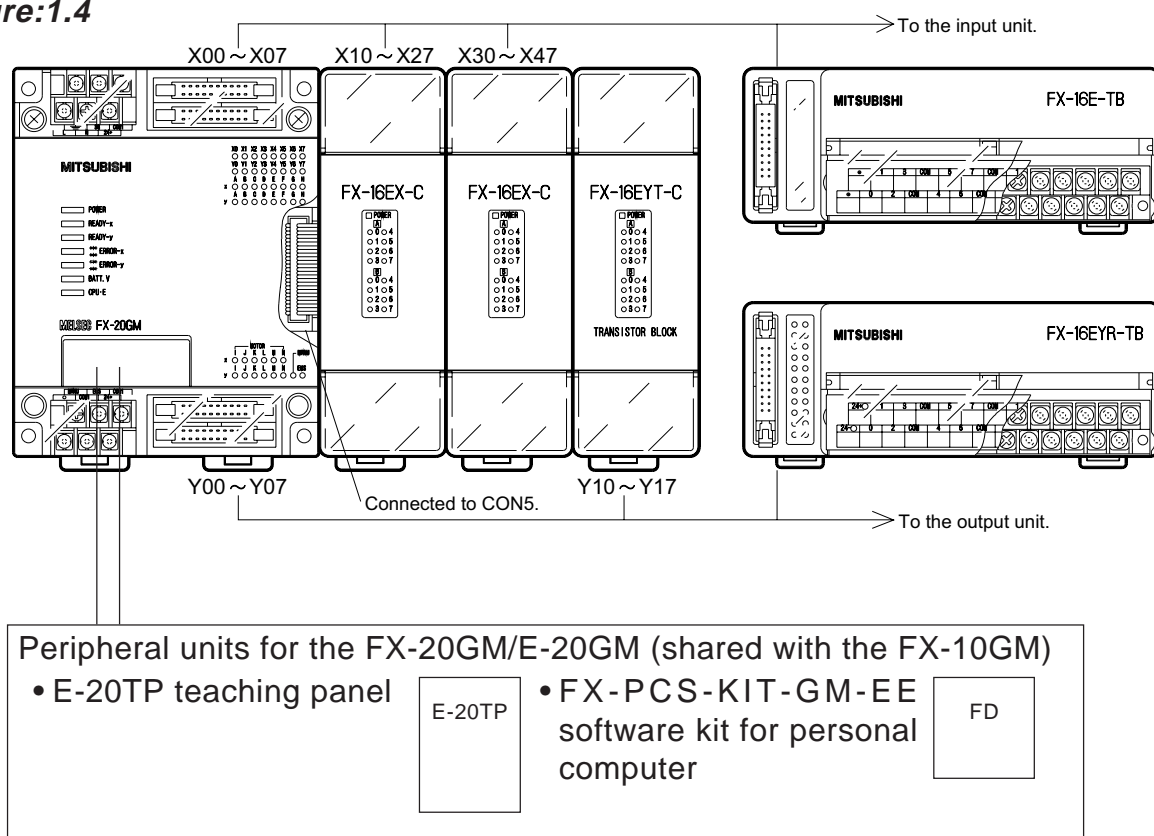

- I/O assignment  
Up to 48 points can be extended to the 16 I/O points (8 input points and 8 output points) built in the positioning unit (Up to 64 points in all are possible.). To each extension point, inputs and outputs are assigned from the point closest to the positioning unit.

### 1.3.3 System configuration and I/O assignment (when a programmable controller is connected)

This section explains the system configuration and an I/O assignment example when the programmable controller is connected. The E-20GM cannot be directly connected to a programmable controller: It must be connected via the general I/Os (Refer to Section 4.4.2.).

When used with a programmable controller.

- The connectors CON6 and CON7 are provided in the FX-20GM to connect directly to the programmable controller.
- Applicable programmable controller: FX or FX<sub>2C</sub> Series

Figure:1.5

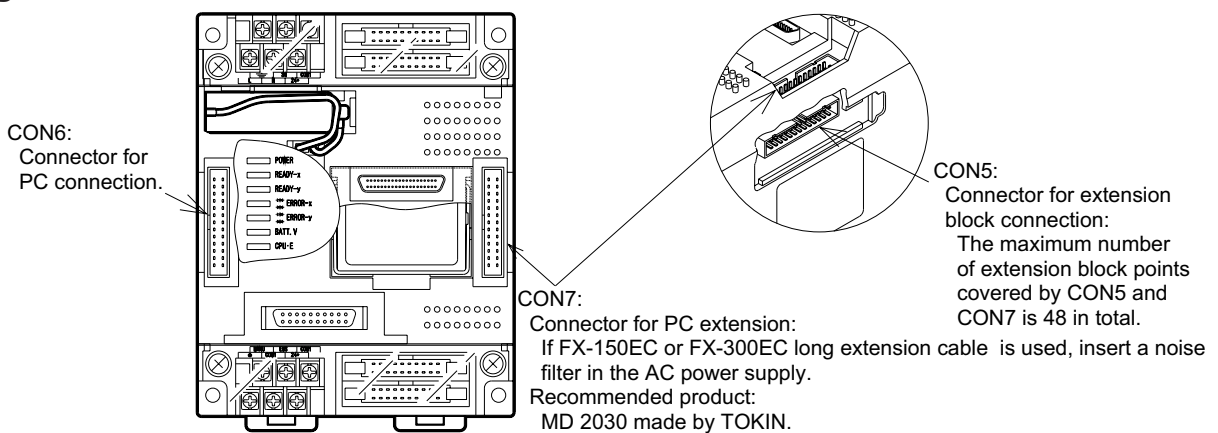

The diagram below indicates the connection among the connectors.

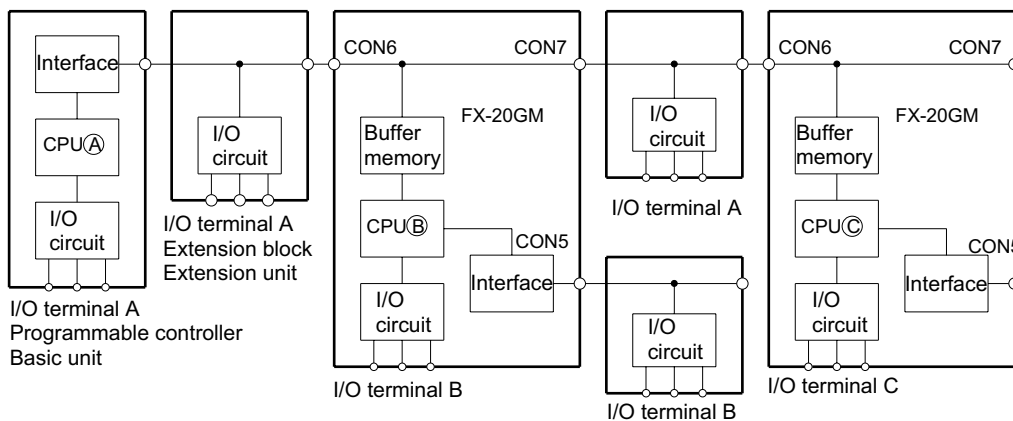

- The FX-20GM functions as a special extension unit for the programmable controller. One FX-20GM unit occupies 8 I/O points. Up to eight FX-20GM units can be connected to one programmable controller.
- CPU A of the programmable controller directly controls the I/O terminals [A].
- CPU B and CPU C in the FX-20GM directly control the output terminals [B] [C] respectively.
- Communication between CPU A and I/O terminals [B]/[C] or between the CPU B/C and I/O terminals [A] can be performed using the FROM/TO instruction inside the programmable controller.



Figure:1.6

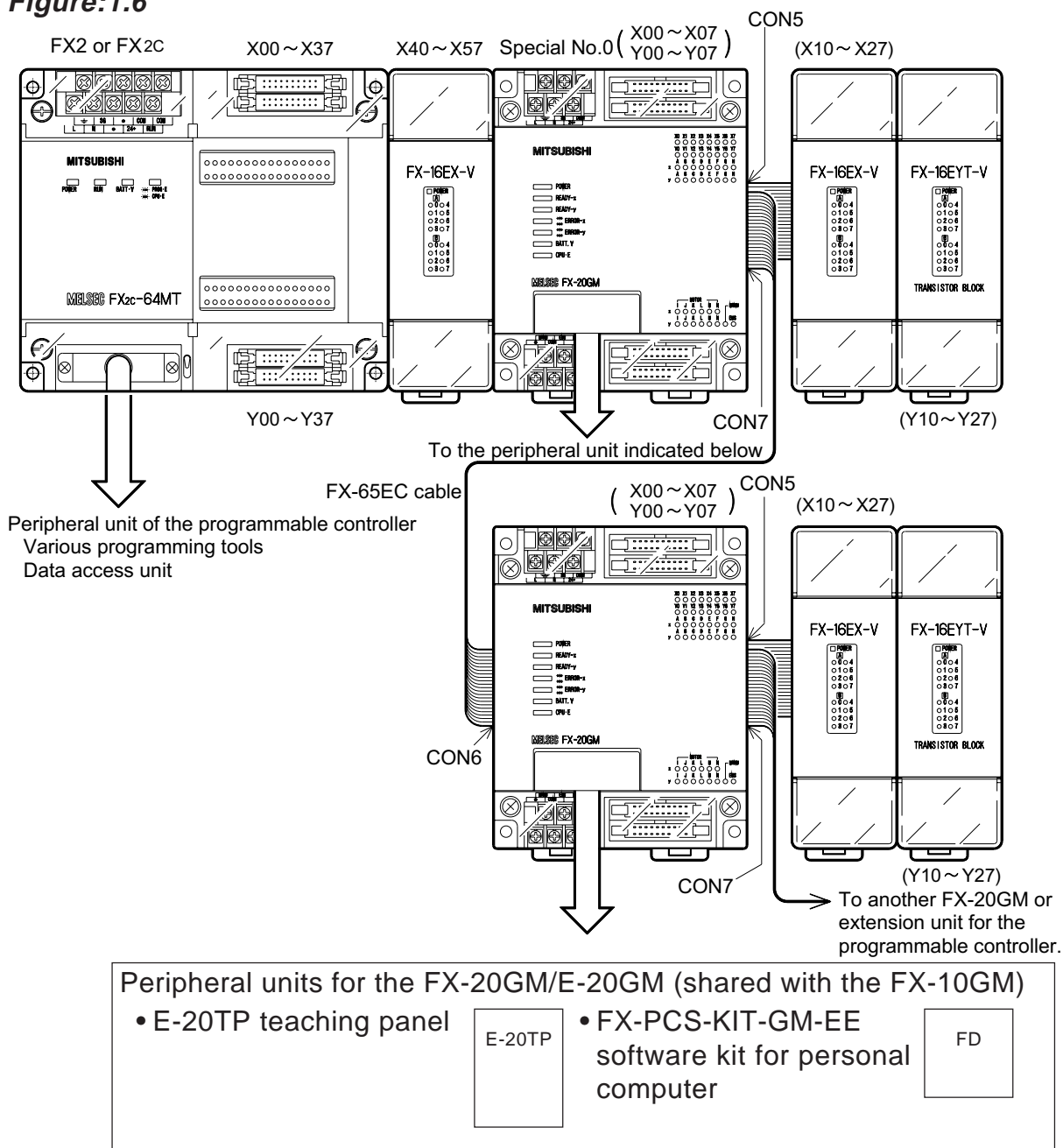

- I/O assignment  
 The FX-20GM is treated as a special unit of the programmable controller. To each extension unit, the special unit No. 0 to 7 is assigned from the unit closest to the programmable controller. The I/O is assigned as follows depending on the connector used.  
 CON5: Treated as an extension of the positioning unit, and gets the I/O No. from the FX-20GM.  
 CON7: Treated as an extension of the programmable controller, and gets the I/O No. from the programmable controller.  
 The number of extension blocks connected to a 20GM is limited. For details, refer to Section 2.5.2.

See also reference service power supply: Section 2.5.2

# MEMO

## 2. SPECIFICATIONS AND WIRING

This section explains the connection between the positioning unit and external functions. Understand sufficiently the specifications of each part before starting wiring.

### 2.1 General Specifications

**Table:2.1 Environmental specifications**

Ambient temperature	Operating: 0 to +55 Storage: -20 to +70	
Ambient humidity	Operating: 35 to 85%RH, non condensing.	
Vibration resistance	Conforms to JIS C0911: 10 to 55Hz, 0.5mm, (2G maximum) *1 2 hours in 3 axis directions.	
Shock resistance	Conforms to JIS C0912: 10G three times in 3 axis directions.	
Noise resistance	By noise simulator with noise voltage 1,000Vp-p, noise width 1 kHz and cycle 30 to 100Hz.	
Withstand voltage	1,500VAC for 1 minute (FX-20GM, E-20GM) 500VAC for 1 minute (FX-10GM).	Between all terminals and ground.
Insulating resistance	5MΩ or more by 500VDC Megger.	
Grounding	Class 3 grounding (with strong power system is not allowed.) *2	
Ambient atmosphere	Free from corrosive gas and excessive dust.	

\*1 0.5G when mounted to a DIN rail.

\*2

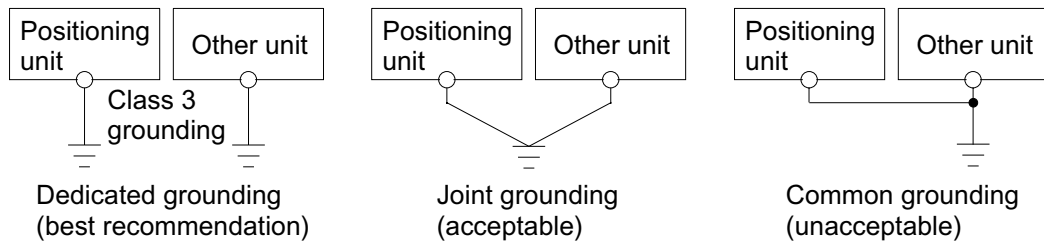



## 2.3 Performance specifications

**Table:2.2 Performance specifications**

Item	Specifications	
	FX-20GM / E-20GM	FX-10GM
Number of control axes	2 simultaneous (Linear interpolation, circular interpolation) or 2 independent.	1
Applicable programmable controller	Bus connection with FX/FX2C Series PC, Number of I/O points occupied: 8/unit. *E-20GM operates independently, and can communicate with general PC at I/O level.	
Program memory	7.8K step RAM built-in. FX-EEPROM-8 or FX-EEPROM-4 EEPROM cassette is available (option).	3.8K step EEPROM built in.
Battery	F2-40BL lithium battery built in. Service life: Approx. 5 years (Guaranteed service life: 1 year).	
Positioning units (incremental / absolute)	Command units: 0.001, 0.01, 0.1 mm, deg. 0.1 inch or 1, 10, 100, 1,000PLS. Max. command value: 7999,999 (indirectly specified: 32 bits).	
Cumulative address	72,147,483,647 pulses.	
Speed commands	200 kPPS max., 153,000 cm/min (not exceeding 200 kPPS). Automatic trapezoidal pattern acceleration/deceleration (However, the limit is 100 kPPS for interpolation operations in the FX-20GM/E-20GM.).	
Zero return	Manual or automatic dog type machine zero return (with the dog search function). Automatic electrical zero return in accordance with the electrical zero position setting is possible.	
Absolute position detection	When using an MR-H servo motor, simple absolute position detection is possible.	
Control inputs	Operation system: MANU (manual), FED (manual forward rotation), RVS (manual reverse rotation), ZRN (machine zero return), START (automatic start), STOP (stop), manual pulse generator (2 kPPS max.), single-step operation input (depending on parameter settings)	
	Mechanical system: Dog (near-point signal), LSF (forward rotation limit) LSR (reverse rotation limit), interrupts: 7 points (4 in the FX-10GM)	
	Servo system: SVRDY (servo ready), SVEND (servo end), PGO (zero-point signal)	
	General purpose: X0 to X7 using the main unit. X10 to X67 (octal) available using extension blocks.	General purpose: X0 to X3
Control outputs	Servo system: PF (forward rotation pulse), RP (reverse rotation pulse), CLR (counter clear)	
	General purpose: Y0 to Y7 using the main unit. Y10 to Y67 (octal) available using extension blocks.	General purpose: Y0 to Y5

Item	Specifications	
	FX-20GM / E-20GM	FX-10GM
Program Nos.	000 to 099 (for simultaneous 2-axis operation), 0x00 to 0x99, 0y00 to 0y99 (for independent 2-axis operation), 0100 (subtask program). For each program, line No.N of up to 4 digits can be designated.	0x00 to 0x99, 0100 (subtask program).
Instructions	positioning	Cod No. system (used with instruction codes), 19 types.
	Sequence	11 types: LD, LDI, AND, ANI, OR, ORI, ANB, ORB, SET, RST, NOP
	Application	FNC No. system, 30 types
M codes	m00: program stop (WAIT) and m102 (END) can be used as required (SFTER mode, WITH mode). For subtasks, m100 (WAIT) and m102 (END) can be used.	m01, m03 to m99 can be used.
Parameters	System setting: 12 types Positioning: 27 types I/O control: 19 types	System setting: 9 types Positioning: 27 types I/O control: 18 types
	Parameter settings (except system settings) can be changed in a program by using special data registers.	
Self-diagnosis	Diagnosis is enabled by the display of parameter errors, program errors and external errors with error code Nos.	
Devices	Inputs: X0 to X67, X372 to X377 Outputs: Y0 to Y67 Auxiliary relays: M0 to M99 (general purpose) M100 to M511 (general purpose)* M9000 to M9175 (special purpose) Counters: P0 to P255 Data registers (16-bit): D0 to D99 (general purpose) D100 to D3999 (general purpose)* D4000 to D6999 (file)* D9000 to D9599 (special purpose) *Back up by battery. Indexes: V0 to V7 (16-bit) Z0 to Z7 (32-bit)	Inputs: X0 to X3, X375 to X377 Outputs: Y0 to Y5 Auxiliary relays: M0 to M511 (general purpose) M9000 to M9175 Counters: P0 to P127 Data registers (16-bit): D0 to D1999 (general purpose) D4000 to D6999 (file) D9000 to D9313 (special purpose) Indexes: V0 to V7 (16-bit) Z0 to Z7 (32-bit)
	Programming tool	E-20TP teaching panel Program (reading / writing, insertion / deletion), parameters (reading / writing), operation monitor, testing (jog, machine zero return,

## 2.4 General installation/wiring work

Please observe the following rules during installation or wiring.  
PC mounting arrangements.

- To prevent a rise in temperature, mount the units to walls. Never mount them to the floor or ceiling of an enclosure.
- Figure 3.4.
- Leave a clearance of 50 mm or more between the main unit and other units or structures.

Examples;

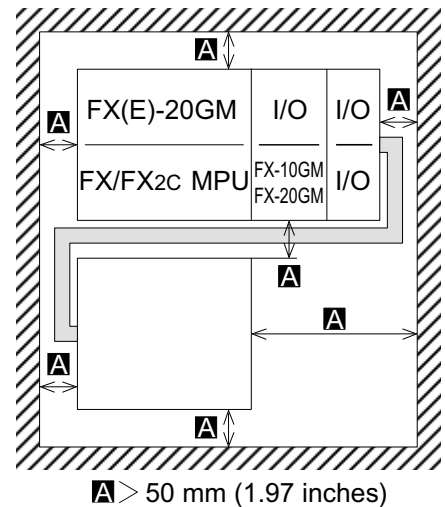
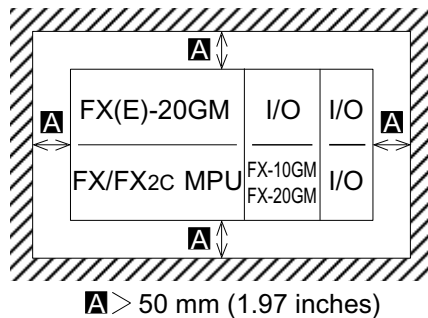

### Caution



- Units should not be installed in areas subject to the following conditions: excessive or conductive dust, corrosive or flammable gas, moisture or rain, excessive heat, regular impact shocks or excessive vibration.
- Take special care not to allow debris to fall inside the unit during installation e.g. cut wires, shavings etc. Once installation is complete remove the protective paper band: to prevent overheating.

### General notes

- Always ensure that mounted units and blocks are kept as far as possible from high-voltage cables, high-voltage equipment and power equipment.

### Wiring cautions

- Do not run input signals in the same multicurie cable as output signals or allow them to share the same wire.
- Do not lay I/O signal cables next to power cables or allow them to share the same trunking duct. Low voltage cables should be reliably separated or insulated with regard to high voltage cabling.
- Where I/O signals lines are used over an extended distance consideration for voltage drop and noise interference should be made.

Mounting method

DIN rail mount

- Units and blocks can be mounted directly to a DIN rail DIN 46277 (Width: 35 mm). (Vibration resistance is 0.5 G. Refer to Section 2.1.)  
To detach a unit or block from the DIN rail, pull the DIN rail hooks down.

Direct mount

The pitch of the mounting screw holes (M4) for direct mounting is shown on the right. For the position of each size, refer to the figure on the right.

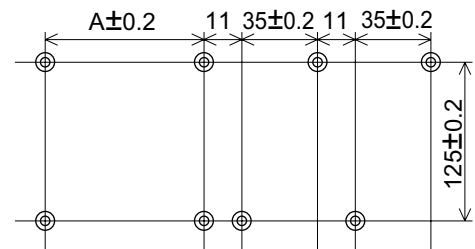

FX-20GM  
E-20GM  
A=100

Extension I/O block  
FX-16EX-C,V  
FX-16EY□-C,V

FX-10GM  
A= 40

Extension I/O block  
Used together with the programmable controller when connected.

Wiring work

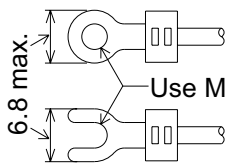

- Use solderless terminals of the dimensions shown in the figure on the left.
- Tighten the terminal screws with a torque of 0.5 to 0.8 N·m (5 to 8 kgf·cm). Tighten them securely to prevent loose connection which may cause malfunction.
- The optional cables used for the connection between CON1 of the FX-10GM or CON1/CON2 of the FX-20GM and the terminal block are shown in Section 2.7.1. If performing the wiring by yourself, use a flat cable or separate wires and follow the instructions described in Section 2.7.1
- For the connection (to the drive unit for the motor) between CON2 of the FX-10GM or CON3/CON4 of the FX-20GM/E-20GM and the terminal block, use the E-GM-200CAB shielded twisted pair cable (2m). Dedicated cables are available for use with Mitsubishi MR-H/MR-J servo amplifiers. If using one of these models, order the E-GMH-200CAB cable (for the MR-H, 2m) or the E-GMJ-200CAB cable (for the MR-J, 2 m). In either case, one cable is required for each axis.

I/O No. labels

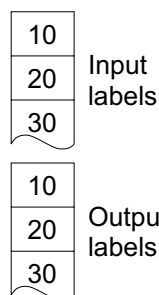

- The No. labels that are supplied with the extension blocks and the terminal blocks should be adhered at every group of 8 points on the I/O terminals of the extension blocks and the terminal blocks. Label groups of 8 inputs, and groups of 8 outputs, in the sequence 10, 20, 30..... starting from the terminal closes to the positioning unit.



## 2.5 Power Supply Specifications and Wiring

This section explains the power supply specifications and wiring of the positioning unit.

### 2.5.1 Power Supply Specifications

**Table:2.3 Power Supply Specifications**

Item	FX-10GM	FX-20GM,E-20GM
Rated voltage	24 VDC	100 ~ 240 VAC
Allowable voltage range	-15% to +10%	
Rated frequency	50/60Hz	
Allowable momentary power interruption time	Continues operation against momentary power interruption of 5 msec or less.	Continues operation against momentary power interruption of 10 msec or less.
Power supply fuse		250V 3A 5φ × 20mm
Power consumption	5W	40VA
Service power supply	Refer to the next page.	

The following points should be observed.

- Turn ON/OFF simultaneously the power of the programmable controller and the power of the positioning unit.
- Use a wire of 2 mm<sup>2</sup> or more for the power supply lines to prevent voltage drop.
- Even if a momentary interruption of 10 msec (5 msec for DC power supply) or less has occurred in the power supply, the positioning unit can continue its operation. When the power has been interrupted for a considerable time or the voltage has abnormally dropped, the positioning unit is stopped and the outputs are turned OFF. When the power supply is recovered, the positioning unit automatically restarts its operation.

### 2.5.2 Service power supply

This section explains the capacity of the 24 VDC service power supply for the positioning unit.

#### FX-10GM

- The drive power supply of the FX-10GM is 24 VDC. There is no 24 VDC service power supply for an external unit.
- When a programmable controller is used, extension blocks can be connected. The maximum total input and output points for non powered extension blocks is 48.
- The capacity of the 5 V power supply for special extension blocks (such as the FX-2DA/4AD analog block, the FX-1HC high-speed counter, etc.) is 100 mA.
- When more than 48 I/O points are needed or when the capacity of the 5 V power supply is insufficient, use powered extension units.

#### FX-20GM / E-20GM

Service power supply specifications.

Number of extension output points ↑	48	80			
	32	140	80		
	16	190	140	80	
	0	250	190	140	80
		0	16	32	48
		→ Number of extension input points			

Example: When an extension with 32 input points and 16 output points is made, the maximum output capacity of the 24 VDC power supply is 80 mA.

- The maximum number of extension input points is 48 and the maximum number of extension output points is 48; the maximum combined total of extension input and output points is also 48. However, since the FX-20GM, E-20GM incorporates 8/8 general purpose I/O points, the maximum overall total is 64 points.
- FX-20GM is capable of supplying power for up to 48 I/O points including a PC extension block. If the I/O points are to be extended exceeding 48 points, use extension units for PC I/Os. **The capacity of the 5 V power supply for the special extension block for PC is 100 mA.**
- The output current of a 24 VDC power supply for sensors varies depending on whether or not an extension block is used. If an overload occurs, the voltage is lowered automatically, deactivating the inputs connected to the E-20GM. Do not connect an external power supply to the [24+] terminal.



### 2.5.3 Power supply connection (FX-10GM)

This section explains the power supply connection of the FX-10GM. For the power supply specifications, refer to Section 2.5.1.

Example of configuration and connection

**Figure:2.3 When the FX-10GM operates independently**

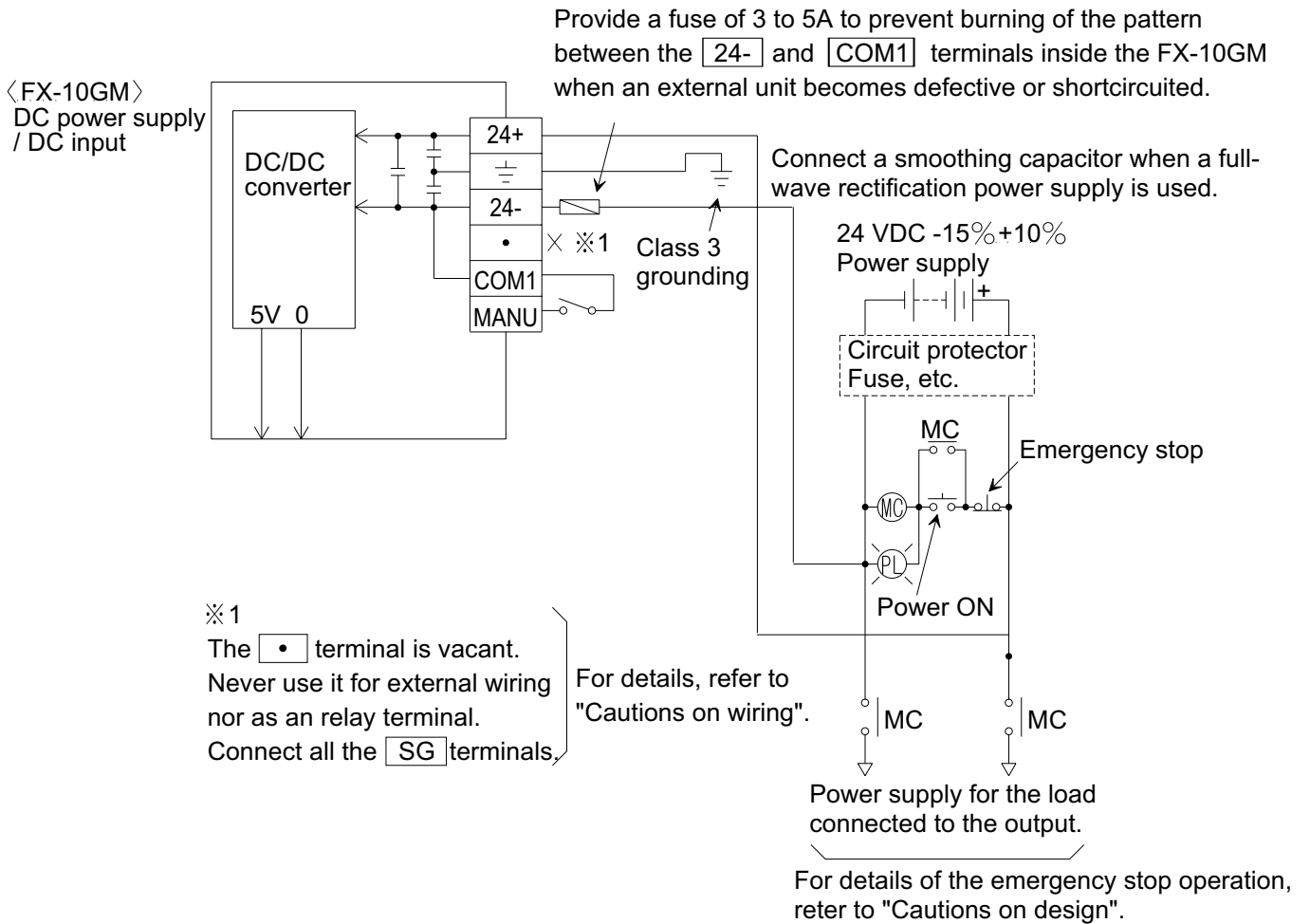

- All general purpose input of the GM unit are configured as SINK inputs.

Example of configuration and connection

Figure:2.4 When the FX-10GM and the programmable controller are used together

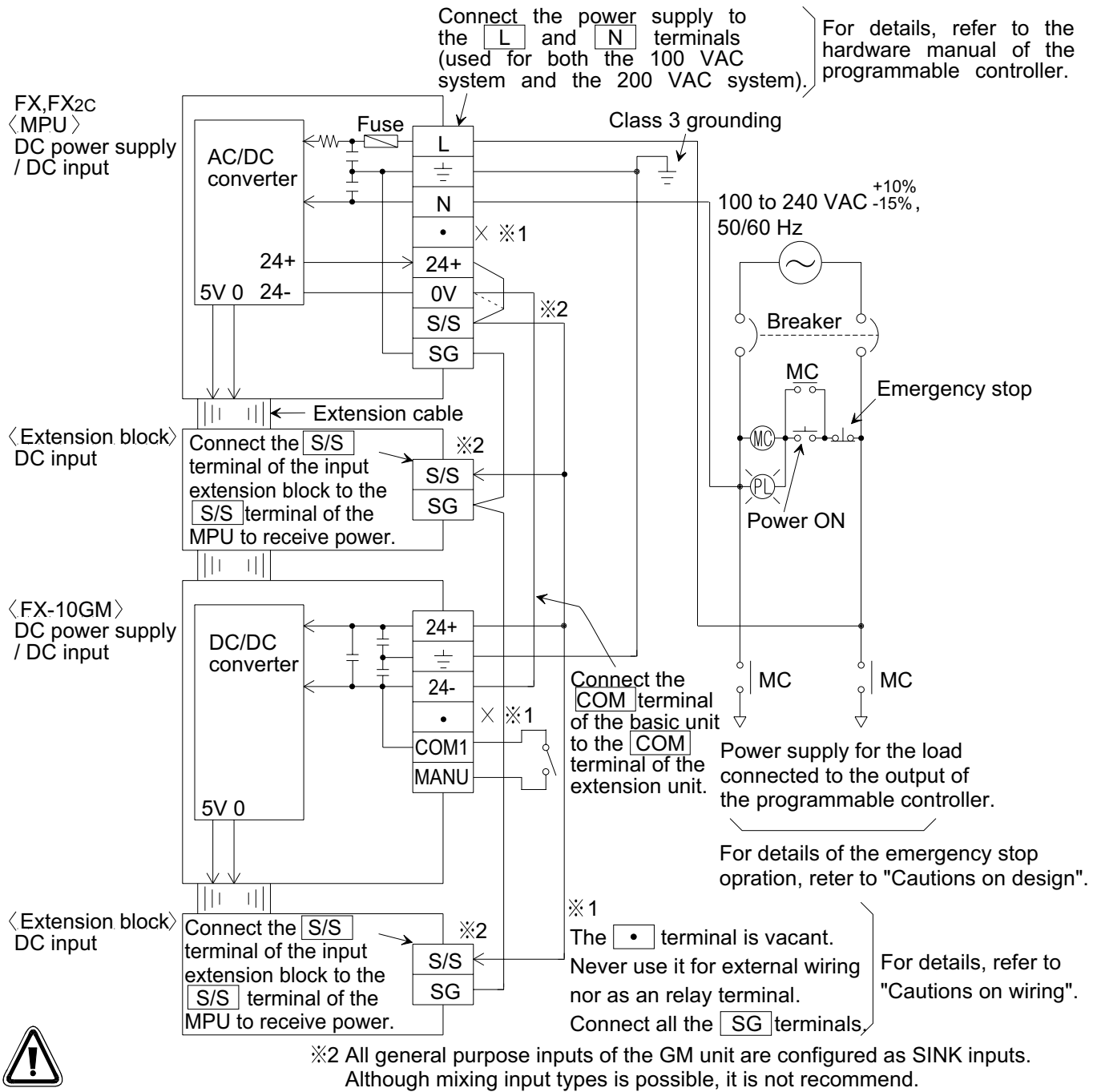

- When the programmable controller is used, refer to the hardware manual of the programmable controller and perform correct wiring.
- When the 24 VDC of the FX-10GM is not supplied from the programmable controller, refer to "When the FX-10GM operates independently" on the previous page.
- For the number of extension blocks connected after the FX-10GM, refer to Section 2.5.2.

Reference

Service power supply: Section 2.5.2

### 2.5.4 Power supply connection (FX-20GM/E-20GM)

Example of configuration and connection

**Figure:2.5 When the FX-20GM/E-20GM operates independently**

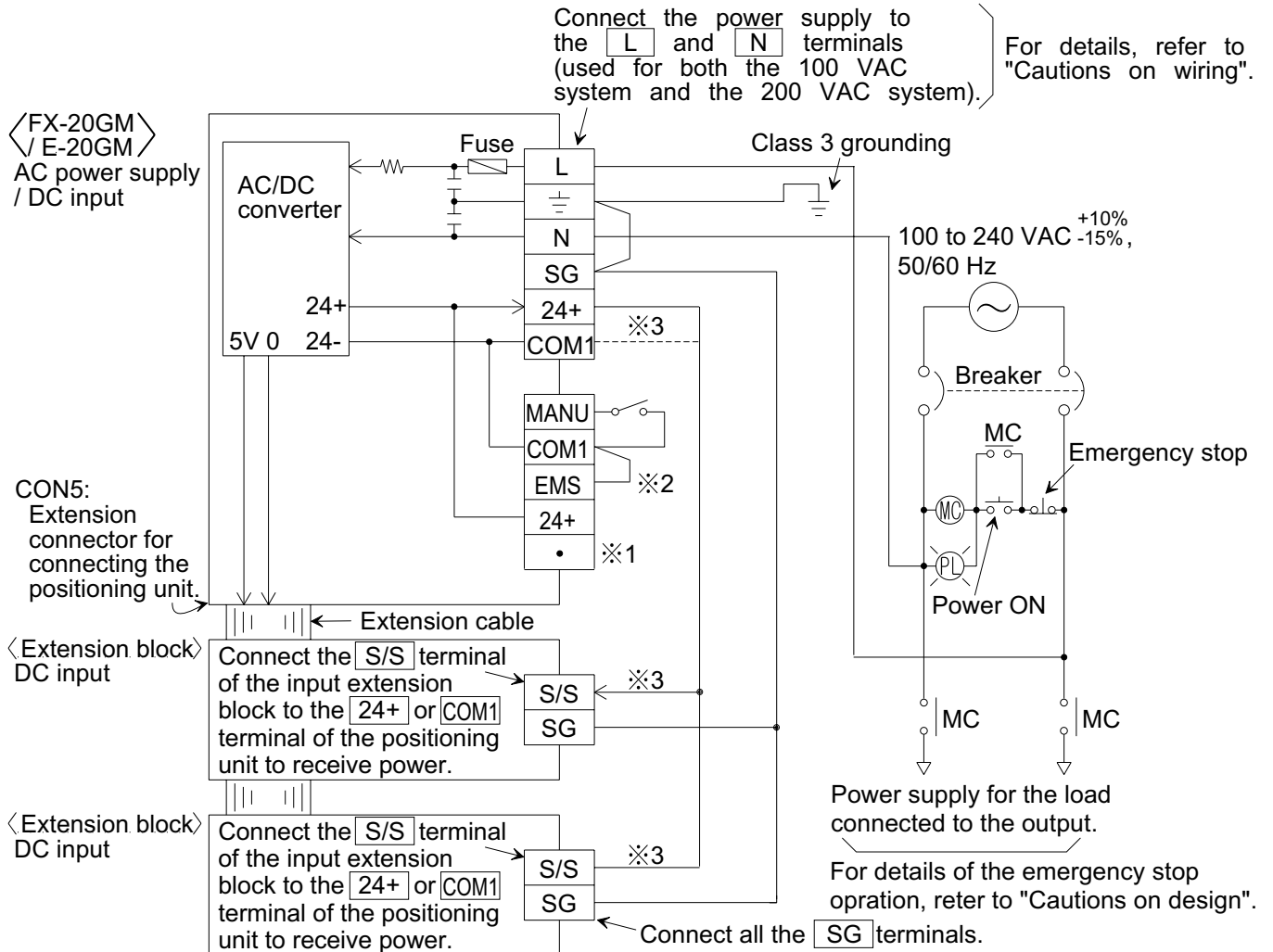

- ※1 The • terminal is vacant. Never use it for external wiring nor as a relay terminal.
- ※2 EMS is the input to drive the FX-20GM / E-20GM system. It should always remain connected with the attached short pin. If the short pin is disconnected or if the input is defective, the positioning unit does not operate (The POWER LED is lit.).
- ※3 All general purpose inputs of the GM unit are configured as SINK inputs. Although mixing input types is possible, it is not recommend.



- For the number of possible extension blocks connected to an FX-20GM/E-20GM and the 24 VDC service power supply, refer to Section 2.5.2.

Reference Service power supply: Section 2.5.2

Example of configuration and connection

**Figure:2.6 When the FX-20GM is used with a programmable controller (Not E-20GM).**

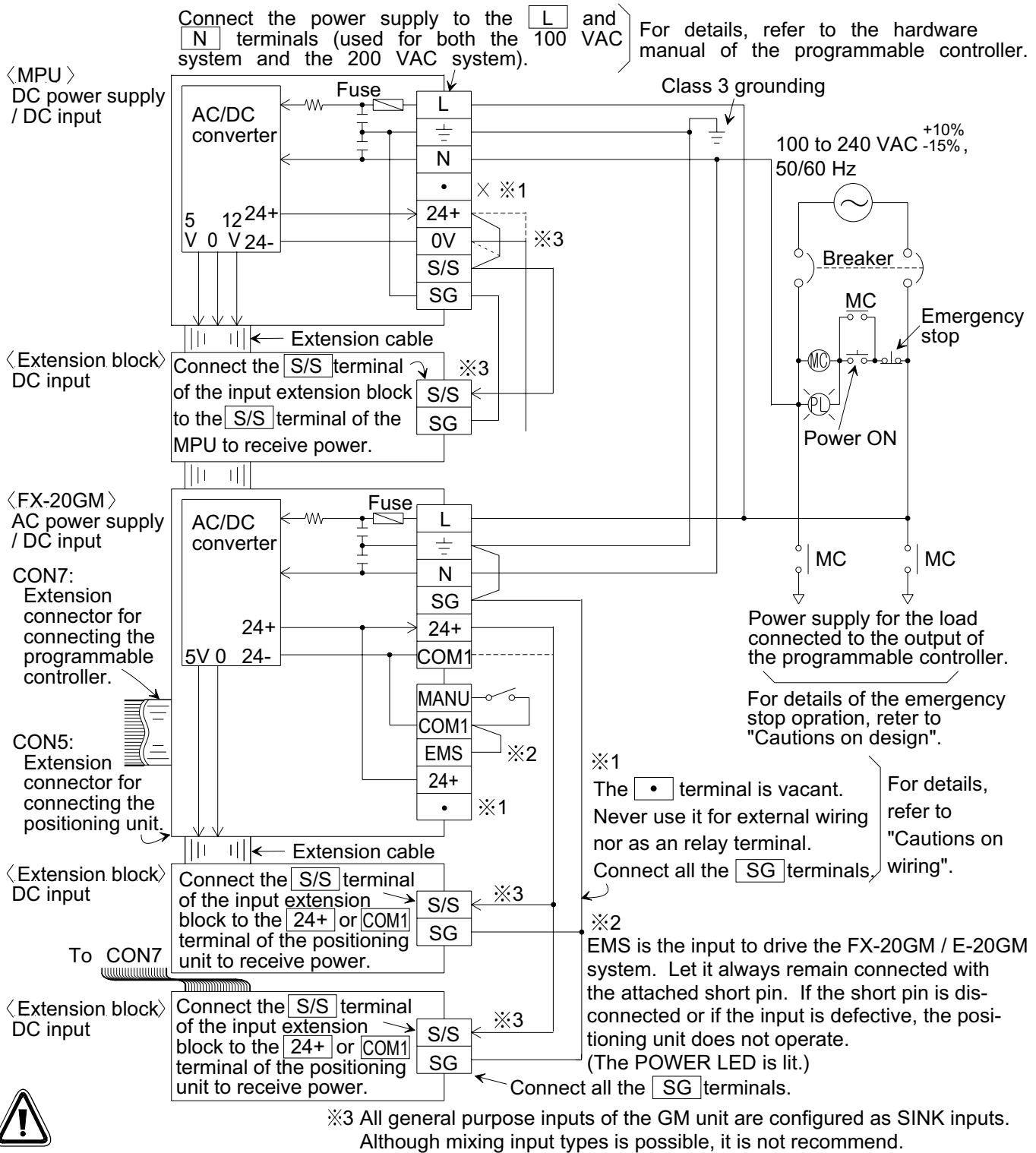

- For the number of possible extension blocks connected to the FX-20GM and the 24 VDC service power supply, refer to Section 2.5.2.

Reference Service power supply: Section 2.5.2

## 2.6 I/O Specifications and Wiring

This section explains the connection with external units and the specifications.

### 2.6.1 Input specifications and external wiring

**Table:2.4 Input specifications and external wiring**

Item	FX-10GM	FX-10GM/20GM,E-20GM	Non-powered extension block input
Input circuit configuration			
Item	FX(E)-20GM		
Input circuit configuration			
Input signal names	Group 1	MANJ EMS (20GM) START STOP ZRN FWD RVS LSF LSR	X10 ~ X67 (20GM) (Total number of general I/O points: 64 max.) (With the FX-10GM, extension I/O are available only when a programmable controller is connected.)
	Group 2	DOG	PGO 2
	Group 3	General inputs X00 to X03 (10GM) X00 to X07 (20GM)	
	Group 4	Manual pulse generator, interrupt inputs	
Circuit isolation	By photocoupler	By photocoupler	By photocoupler
Operation indication	LED is lit while input is ON.	LED is lit while input is ON.	LED is lit while input is ON.
Signal voltage	24 VDC $\pm$ 10% (internal power supply)	5 to 24 VDC $\pm$ 10%	24 VDC $\pm$ 10%
Input current	7 mA / 24 VDC	7 mA / 24 VDC (PGO 11.5 mA / 24 VDC)	7 mA / 24 VDC
Input ON current	4.5 mA or more	0.6 mA or more (PGO 1.5 mA or more)	4.5 mA or more
Input OFF current	1.5 mA or less	0.3 mA or less (PGO 0.5 mA or less)	1.5 mA or less
Signal format	Contact input or NPN open collector transistor input.		
Response time	Group 1	Approx. 0.5 msec	Approx. 10 msec
	Group 2	Approx. 3 msec	
	Group 3	Approx. 0.1 msec 1	
	Group 4	Approx. 3 msec 1	

Notes 1 to 3 are described on the next page.

- 1 The selection of general purpose inputs, manual pulse generator inputs or interrupt inputs in the parameter settings automatically adjusts the input filters. The maximum response frequency for the manual pulse generator is 2 kPPS.
  
- 2 When using a stepping motor, short-circuit [ST1] and [ST2] terminals (X axis, including the 10GM) as well as the [ST3] and [ST4] terminals (Y axis) to each other to reduce the PGO resistance from 3.3 k $\Omega$  to 1 k $\Omega$ .  
The input current also changes.  
PGO 4.9 mA/5 VDC ON at 1.5 mA or less  
OFF at 0.5 mA or less
  
- 3 In the case of the FX-20GM/E-20GM, the 24 VDC service power supply can be used as the input power supply (Refer to Section 2.5.2.).



### DC input circuit

- **Input terminals**  
The input is turned ON when the input terminal is connected to the [COM] terminal by a no-voltage contact or an NPN open collector transistor. When the input is turned ON, the input indicator LED is lit.  
If two or more common terminals [COM] are provided, they are connected inside the positioning unit.

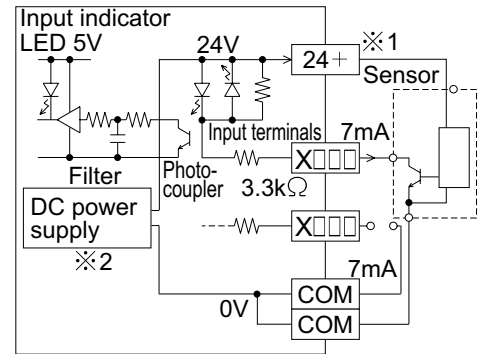

- 1 24 VDC is supplied to the FX-10GM from the outside.
- 2 Not applicable in the FX-10GM.

- **Input circuits**  
The primary and secondary input circuits are isolated by a photocoupler, and a C-R filter is provided in the secondary circuit. This prevents malfunction due to input contact chattering or other noises that may enter via the input line.
- **Input sensitivity**  
The input current for the positioning unit is 24 VDC, 7 mA, but correct ON and OFF operations can be ensured by currents of at least 4.5 mA for ON and not more than 1.5 mA for OFF. Note that the I/O contact may fail to turn ON properly if a diode or resistor is connected to it in series or fail to turn OFF properly if there is a resistor connected in parallel with it or if there is any leak current.

#### External circuit for sensor:

The input current for the FX-20GM/E-20GM is supplied from the 24 VDC power supply inside the FX-20GM/E-20GM.

Therefore, if a sensor such as a photoelectric switch is driven by an external power supply, the voltage should be 24VDC  $\pm$  4 VDC and the output transistor of the sensor must be the NPN open connector type.

However, if the output transistor has sufficient withstanding voltage and the diode and the resistor indicated with dotted line in the figure below are not incorporated in the sensor (open collector), it does not matter if a different external power supply voltage is used.

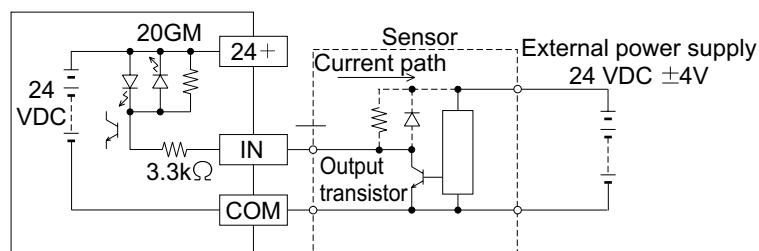

Figure:2.7 Input connection example for the FX-10GM

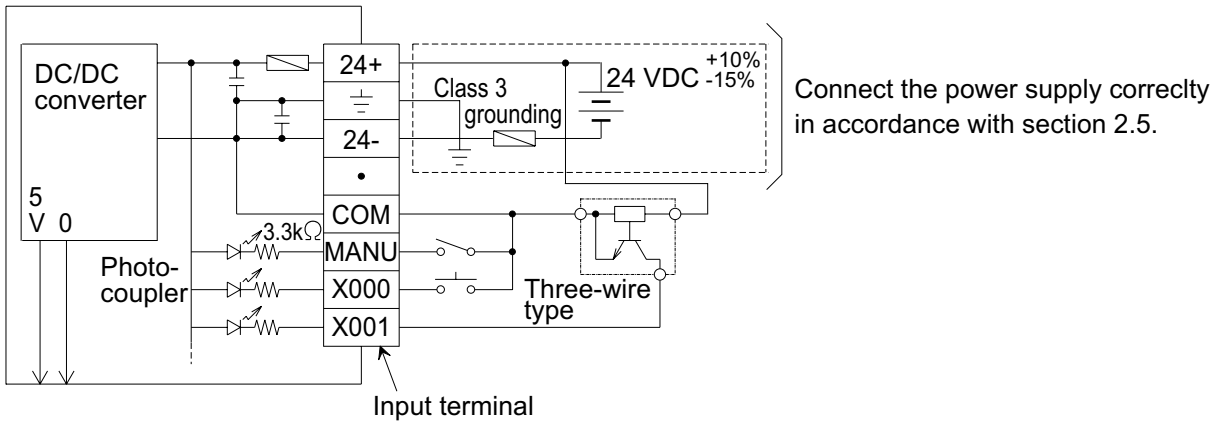
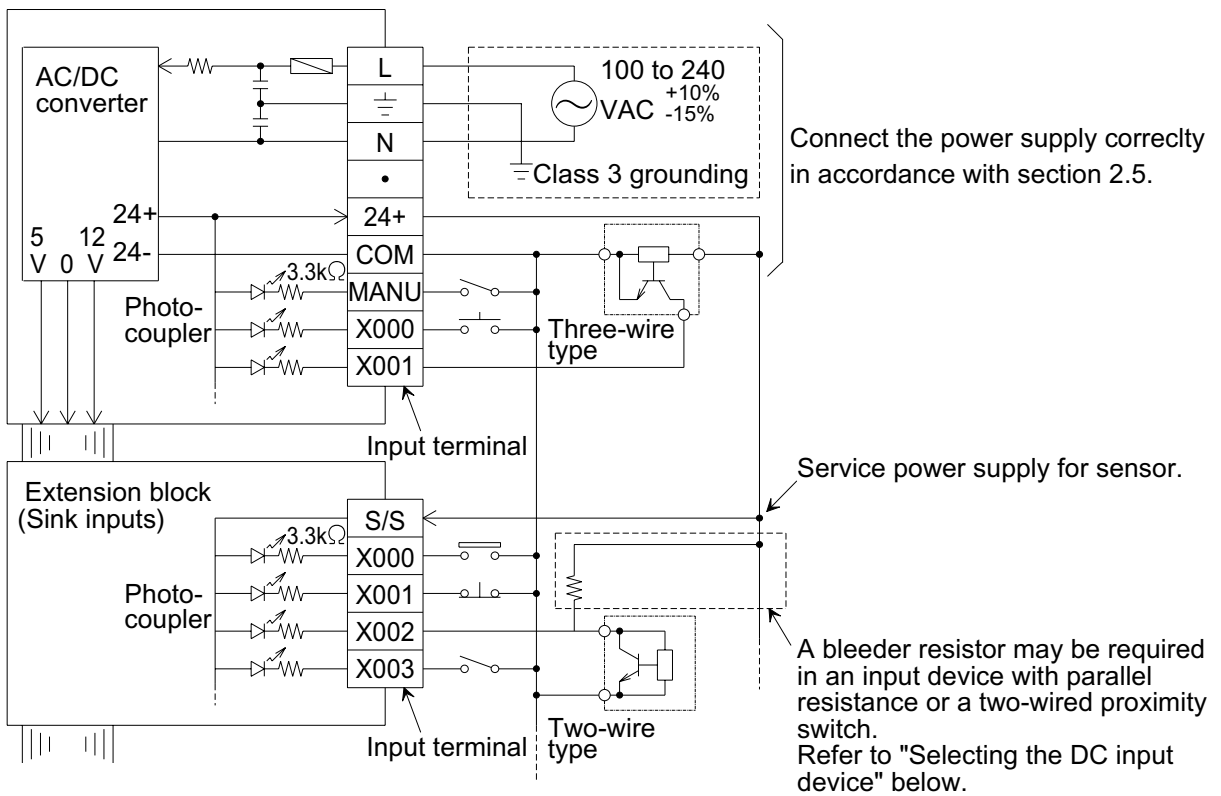

Figure:2.8 Input connection example for the FX(E)-20GM



### Selecting DC input device

The input current for the positioning unit is 24 VDC, 7 mA (internal power supply). Use a small-sized input device suited to this low current.

Example: Following products manufactured by OMRON

Micro switch: Z, V, D2RV Proximity switch: TL, E2M

Operation switch: A3P Photoelectric switch: E3S, E3N

Imperfect contact may occur when a switch for large current is used.

Input device with diodes connected in series

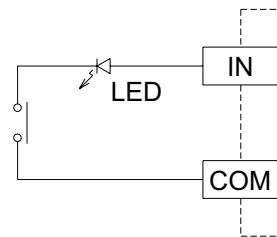

Make sure that the voltage drop of the diodes connected in series is approximately 4 V or less. Accordingly, in the case of a lead switch with LEDs connected in series, two or less LEDs can be connected in series.

Input device with resistors connected in parallel or two-wired proximity switches.

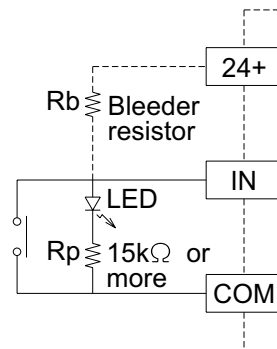

Make sure that the parallel resistance  $R_p$  is 15 k  $\Omega$  or more. When  $R_p$  is less than 15 k  $\Omega$ , connect a bleeder resistor  $R_b$  satisfying the following formula between the [24+] and [IN] terminals.

$$R_b = \frac{4R_p}{15 - R_p} \text{ (k } \Omega \text{)}$$

Make sure that the leak current  $I_l$  is 1.5 mA or less when the two-wired proximity switch is turned OFF.

When  $I_l$  exceeds 1.5 mA, connect a bleeder resistor  $R_b$  satisfying the following formula in the same way.

$$R_b = \frac{6}{I_l - 1.5} \text{ (k } \Omega \text{)}$$

2.6.2 Output specifications and external wiring

Table:2.5 Output specifications and external wiring

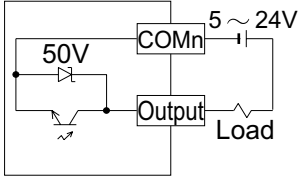
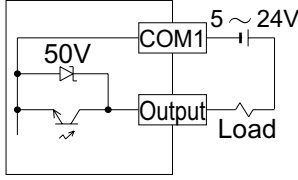
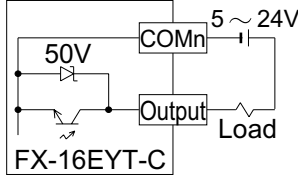
Item	Positioning unit drive output	Positioning unit general purpose output	FX-16EYT-C extension block
Output circuit configuration			
Output signal names	FP (FP0), RP (RP0) CLR	X00 ~ X05 (10GM) Y00 ~ X07 (20GM)	X10 ~ X67 (With the FX-10GM, extension I/O are available only when a programmable controller is connected.) (Total number of general I/O points: 64 max.)
Circuit isolation	By photocoupler	By photocoupler	By photocoupler
Operation indication	LED is lit while output is ON.	LED is lit while output is ON.	LED is lit while output is ON.
External power supply	5 to 24 VDC $\pm$ 10%	5 to 24 VDC $\pm$ 10%	5 to 24 VDC $\pm$ 10%
Load current	20 mA or less	50 mA or less	0.3 A / 1 point, 1.6 A / 16 points
Open circuit leak current	0.1 mA / 24 VDC or less	0.1 mA / 24 VDC or less	0.1 mA / 24 VDC or less
Output ON voltage	0.5 V max. (1.5 V max. for CLR)	0.5 V max.	1.5 V max.
Response time	For pulse outputs FP (FP0) and RP (RP0): 200 kPPS max. Pulse output width of CLR signal: Approx. 20 msec	0.2 msec max. for both OFF ON and ON OFF.	0.2 msec max. for both OFF ON and ON OFF. (when load is 0.1 A).

### Transistor output circuit

- Output terminals:**  
 The output terminals of the positioning unit are located in a 16-point connector in which both inputs and outputs are located. The power supply for driving the loads must be 5 to 30 VDC smoothed power supply.
- Circuit isolation:**  
 The internal circuits of the positioning unit are isolated optically from the output transistors by a photocoupler. In addition, each common block is isolated from the others.
- Operation indication:**  
 When a photocoupler is driven, the LED is lit and the output transistor is turned ON.
- Response time:**  
 For the response time between activation or deactivation of a photocoupler and turning ON or OFF of an output transistor, refer to the table on the previous page.
- Output current:**  
 The current shown in the table on the previous page is possible at each output point.  
 The ON voltage of an output transistor is approximately 1.5 V.  
 When driving semiconductors, etc., make sure that the input voltage of the device does not exceed this value.
- Leak current in open circuit:**  
 The leak current is 0.1 mA or less.

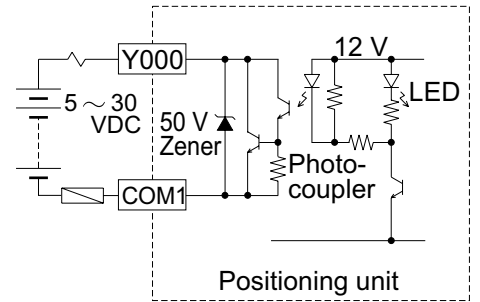

Output connection example

Figure:2.9 Output connection example

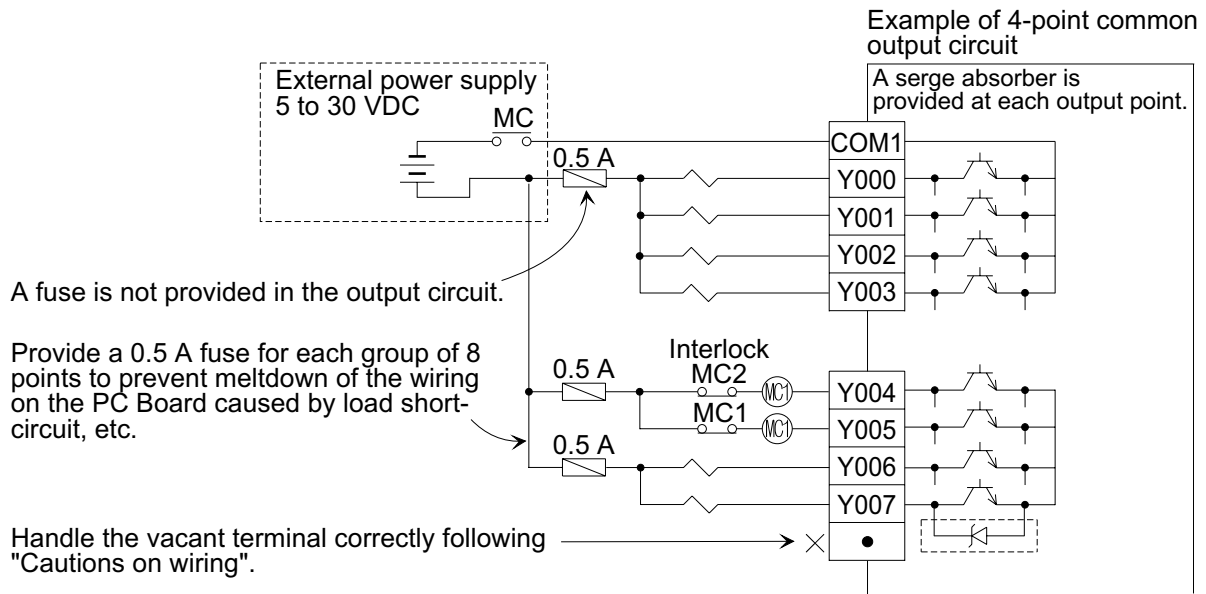

Output circuit configuration

Figure:2.10 Output circuit configuration

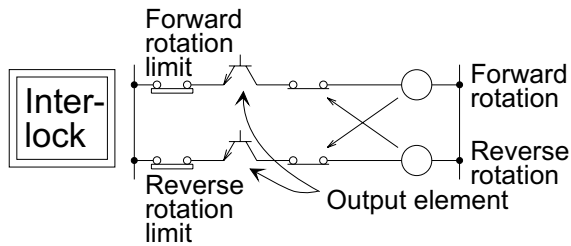

For pairs of inputs such as forward/reverse rotation contacts which would pose a hazard if turned ON simultaneously, provide external interlocks, in addition to interlocks in the program inside the positioning unit, to ensure that they cannot be turned ON simultaneously.

### 2.6.3 Operation input wiring

This section explains the wiring of the operation inputs such as change-over of start/stop and MANU/AUTO. Perform the actual wiring work while referring to "2.6.1 Input specifications and wiring".

**Figure:2.11 Operation input wiring**

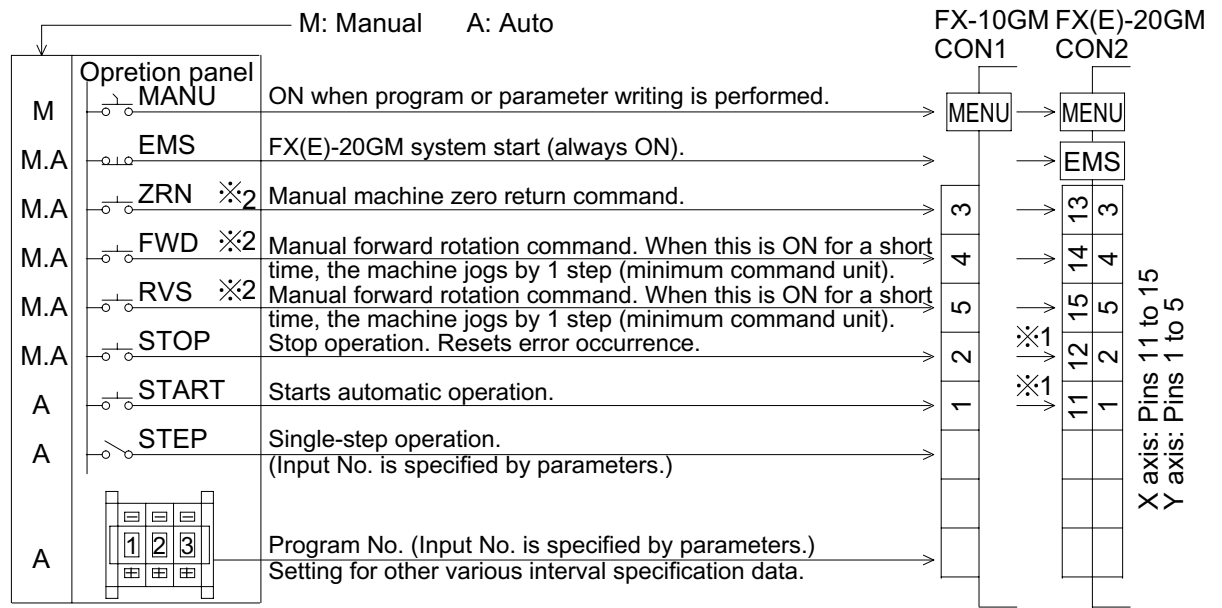

#### General purpose input declaration

- Parameter No. 56 (PARA 56)  
 When the general purpose input declaration is set to "1" or "3", the input terminals [ZRN], [FWD] and [RVS] can be used as general purpose inputs in AUTO mode. The wiring and input No. at this time are shown in the figure below.

**Figure:2.12 Parameter No. 56 (PARA 56)**

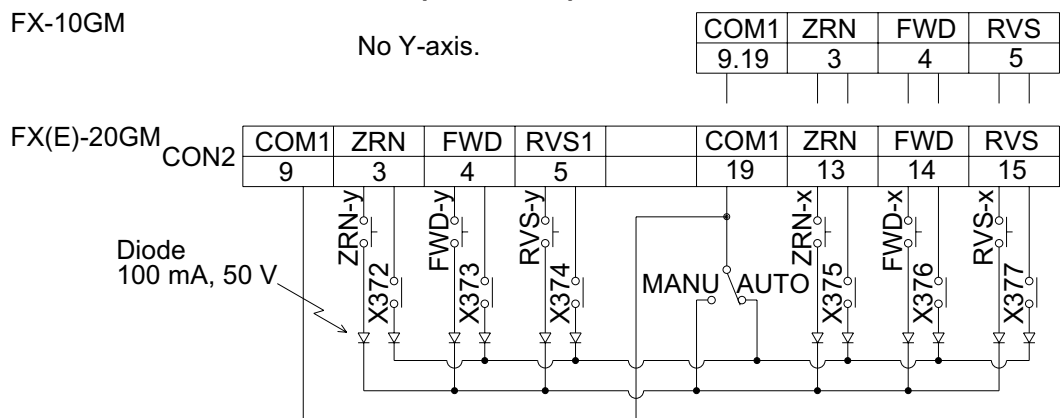

2.6.4 Drive system/mechanical system I/O wiring

This section explains the I/O of the drive system and the mechanical system such as the drive unit, forward/reverse rotation limit, near-point DOG, etc. Refer to the manual of the drive unit or sections 2.6.1 and 2.6.2 in this manual before correctly performing the actual wiring. Section 8 indicates a wiring example of the drive unit of a Mitsubishi servo motor. Refer to Section 8 also.

Figure:2.13 Drive system/mechanical system I/O wiring

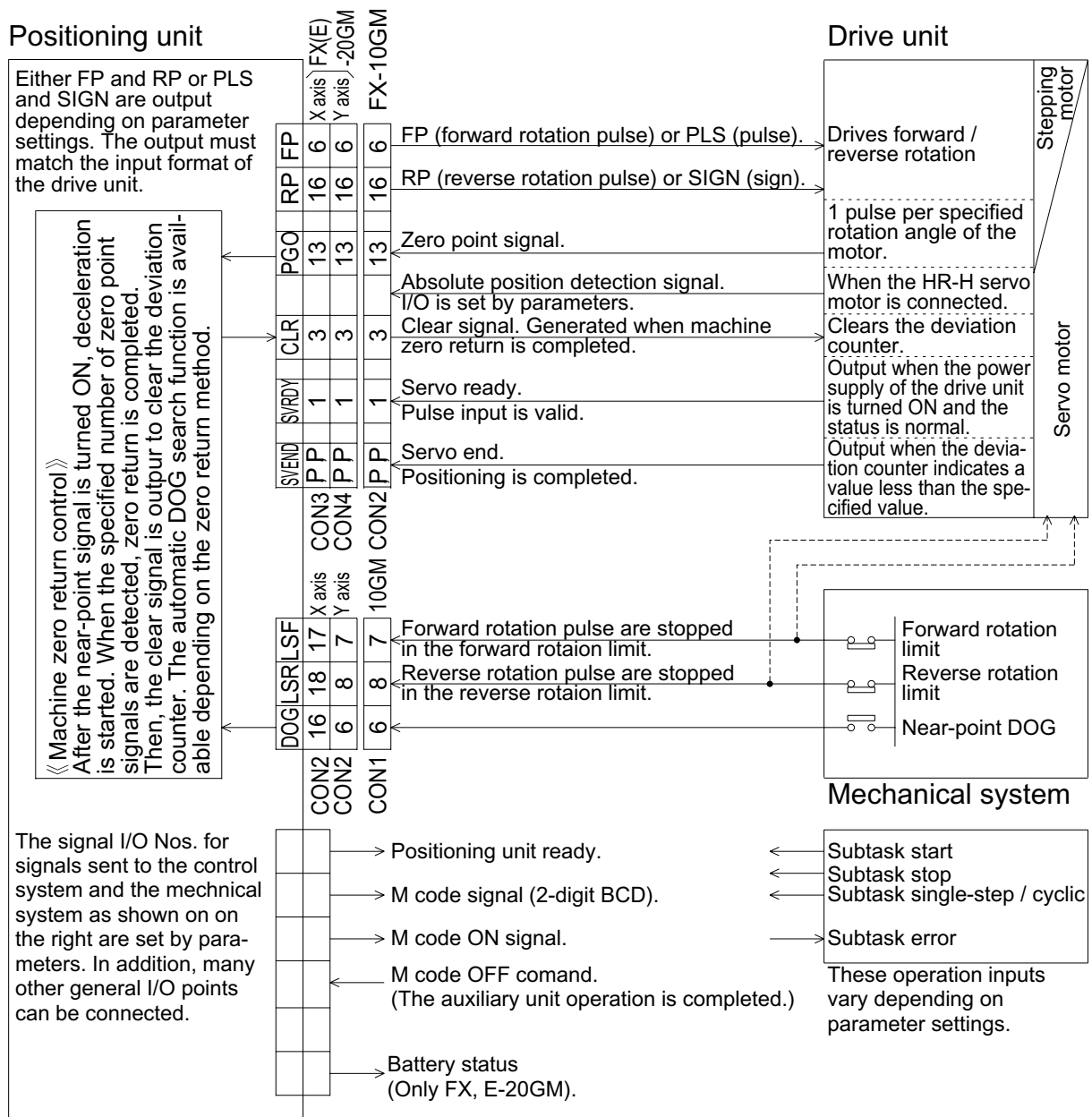

Reference

- Input specifications and external wiring: Section 2.6.1
- Output specifications and external wiring: Section 2.6.2
- Motor connection example: Section 8.1





### 2.6.6 Manual pulse generator wiring

This section explains the wiring when a manual pulse generator is used.

- When a manual pulse generator is used, parameter settings are required. In the wiring shown below, the parameters are set as follows.
  - |                                 |  |
|---------------------------------|--|
| PARA 39: Manual pulse generator | Set to "1": One pulse generator. (FX-10GM)   |
|                                 | Set to "2": Two pulses generator. (FX-20GM and E-20GM)   |
| PARA 40: Magnification ratio    | Set according to necessity.  |
| PARA 41: Division               | Set according to necessity. (Not available in the FX-10GM.)  |
| PARA 42: Enable input           | One manual pulse generator can be changed over for the X axis or the Y axis in the FX-20GM/E-20GM. |

Figure:2.16

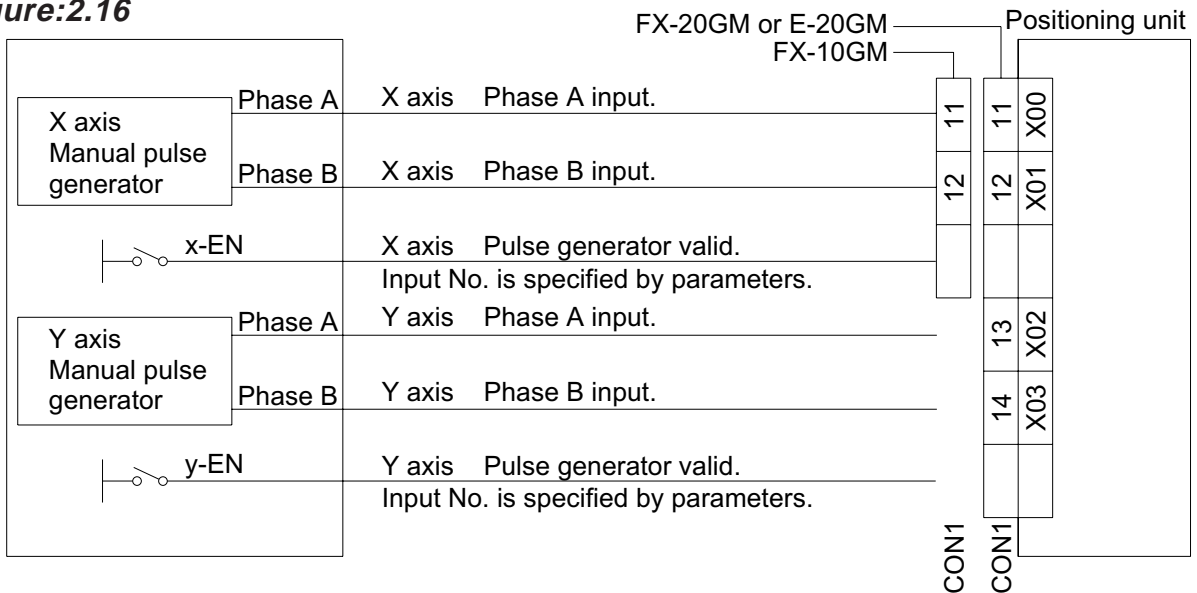

※ In the case of FX-20GM or E-20GM, one pulse generator can be switched between the X axis or the Y axis.

- Have in mind that the following operation is performed when a manual pulser is used together with the FX-10GM.

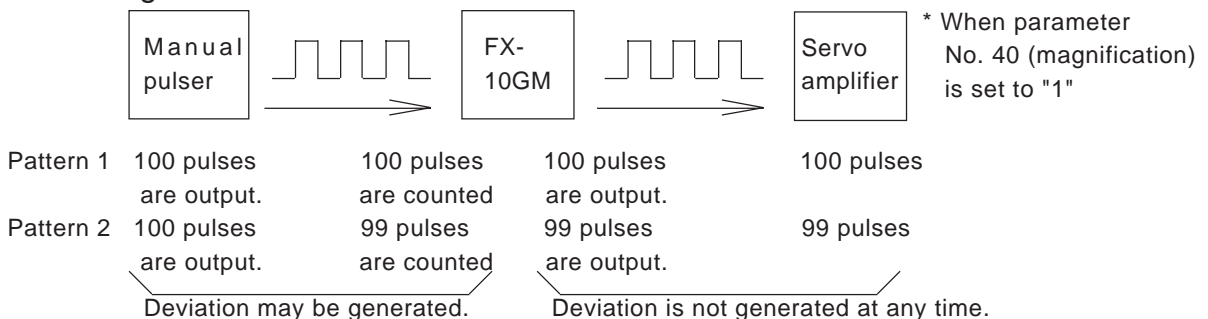

When the manual pulser function of the FX-10GM is used, 100 pulses output from a manual pulser may be counted as 99 pulses as shown in the pattern 2 above.

However, no deviation is generated between the current value in the 10GM and the current value in the servo amplifier because the number of pulses counted in the 10GM is always equivalent to the number of pulses output to the servo amplifier.

## 2.7 Optional Units

This section explains the optional units which can be used with the positioning unit.

### 2.7.1 I/O cables and connectors

When an I/O connector of the positioning unit is connected to a terminal block, the following cables are convenient.

#### Optional cables

The following optional cables are available to connect the positioning unit.

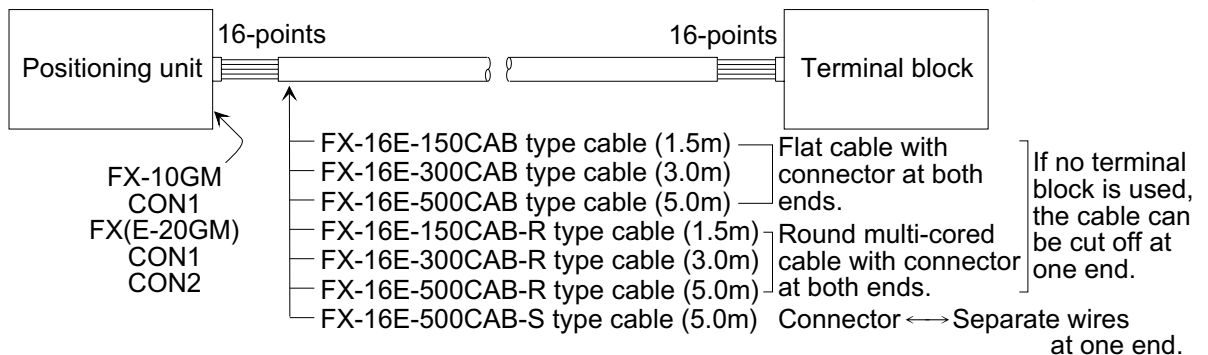

For connection with the motor drive unit, use the cables indicated on the next page.

#### Applicable connectors

The specifications for connector cables made by the user and for the connectors to be used when connecting additional equipment are indicated below.

##### When making a cable

Flat cables  
Wire size: AWG28 (0.1 mm<sup>2</sup>)  
1.27 pitch, 20 cores  
Example of pressure displacement connectors (female)

- HIF3BA-20D-2.54R Hirose Denki
- FRC5-A020-3TOS Daiichi Denshi
- FRC2-A020-30S Daiichi Denshi

Separate wires  
Wire size: AWG22 to 20 (0.3 to 0.5 mm<sup>2</sup>)  
Solderless contacts: HU-411S (0.3 mm<sup>2</sup>)  
Daiichi Denshi  
HU-411SA (0.5 mm<sup>2</sup>)  
Daiichi Denshi  
Housing: HU-200S2-001 Daiichi Denshi  
Depending on the variation in sheath thickness, it may be difficult to accommodate the wires in the housing.  
UL-1061 wires are recommended.

##### When connecting additional equipment

The destination side connectors to which Mitsubishi's optional cables can be connected include the following models.

- HIF3BA-20PA-2.54DSA Hirose Denki
- FRC5-C20S53T-OL Daiichi Denshi
- FRC2-C20S13-OL Daiichi Denshi

The internal connectors of the positioning unit and extension blocks are equivalent to the models indicated above.

2.7.2 Motor connection cables

The positioning unit can easily be connected to a Mitsubishi servo motor amplifier using the following cables.

Figure:2.17 Motor connection cables

**E-GMC-200CAB** For MR-C, 2 m  
 To CON2 of FX-10GM,  
 To CON3 or CON4 of FX(E)-20GM.

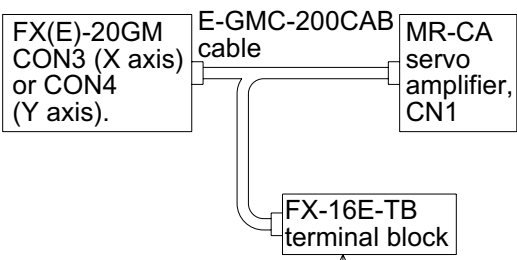
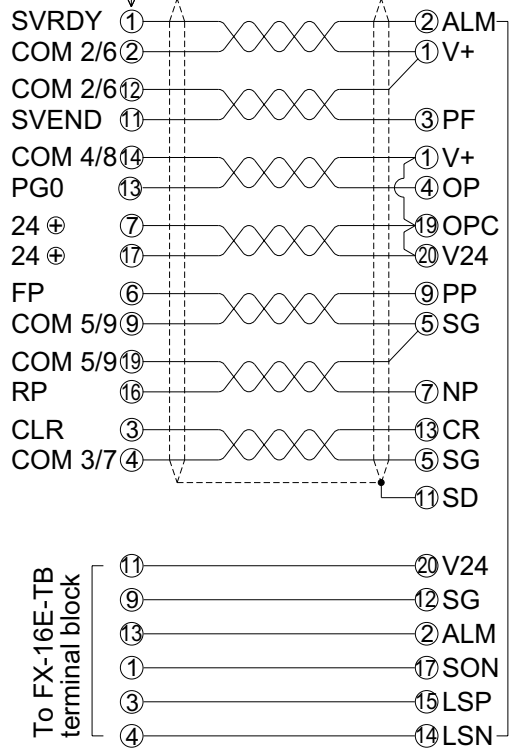

For details of the command input terminal Nos. for the servo motor, refer to Section 2.7.3.

**E-GMH-200CAB** For MR-H, 2 m  
 To CON2 of FX-10GM,  
 To CON3 or CON4 of FX(E)-20GM.

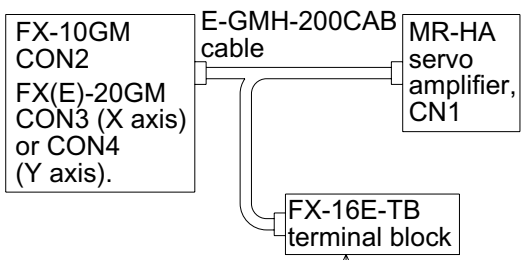
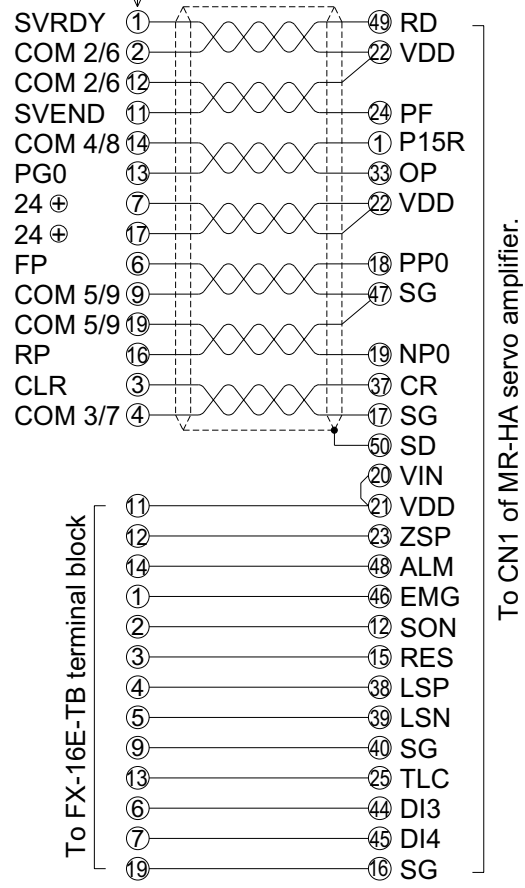

For details of the command input terminal Nos. for the servo motor, refer to Section 2.7.3.

**E-GMJ-200CAB** For MR-J, 2 m  
 To CON2 of FX-10GM,  
 To CON3 or CON4 of FX(E)-20GM.

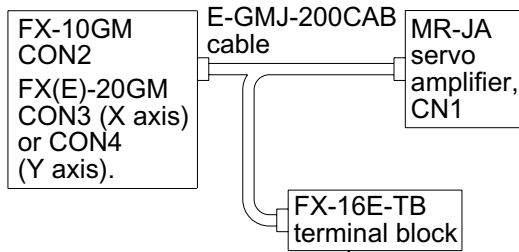
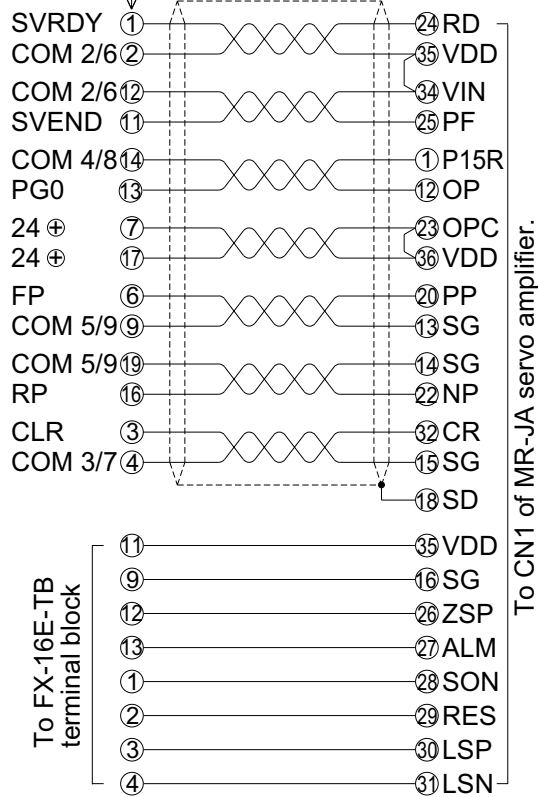

For details of the command input terminal Nos. for the servo motor, refer to Section 2.7.3.

**E-GMJ2-200CAB1A** For MR-J2, 2 m  
 To CON2 of FX-10GM,  
 To CON3 or CON4 of FX(E)-20GM.

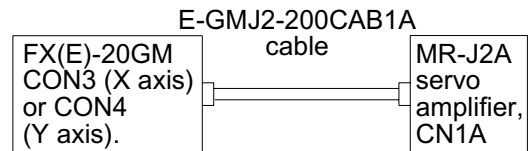
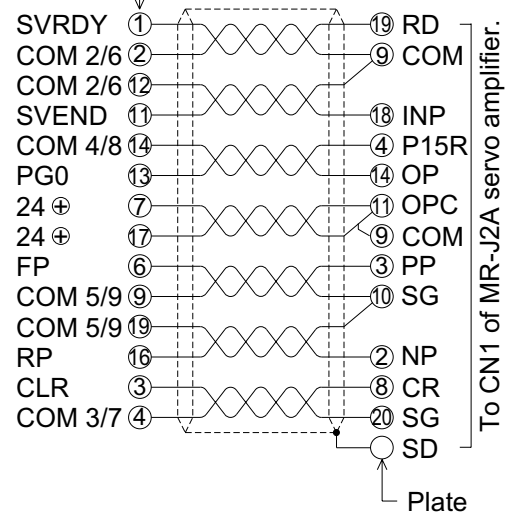

- The positioning unit can be connected to a general purpose drive unit manufactured by any company other than Mitsubishi using the following cable.

**E-GM-200CAB** For general pupose drive unit, 2 m

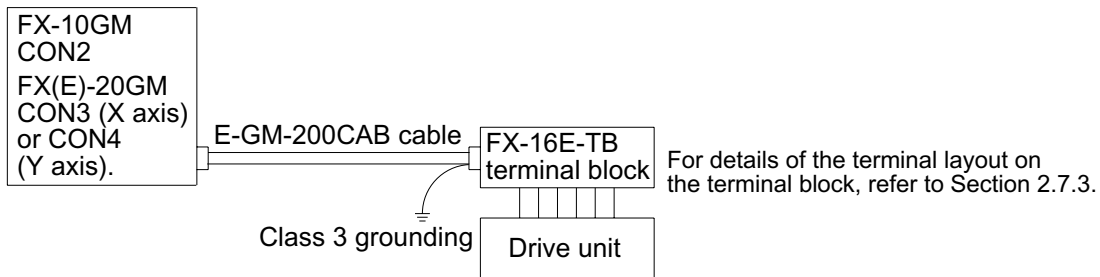
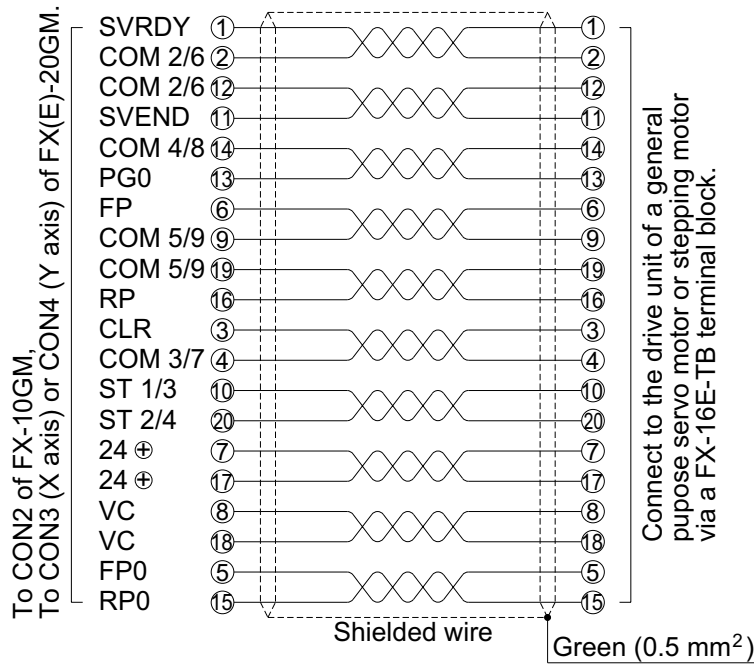

### 2.7.3 Terminal block

The terminal block converts the I/Os of the positioning unit and the connector I/Os of the connector type extension block (described in Section 2.7.4).

Note that the FX-16EY(R, T, S)-TB and FX-16EYT-H-TB output terminal blocks cannot be connected to the input/output connector of the positioning unit.

#### Specifications

- Other general specifications are equivalent to those of the positioning unit (Refer to Section 2.1.).

**Table:2.6 Specifications**

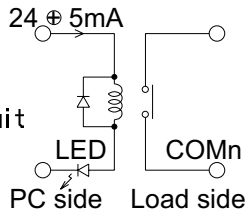
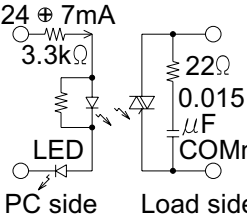
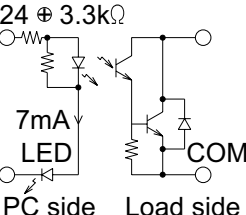
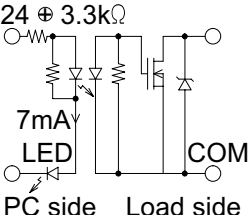
Item	Relay output FX-16EYR-TB	Triac output FX-16EYS-TB	Transistor output FX-16EYT-TB	Transistor output FX-16ET-H-TB	
I/O configuration circuit					
Load voltage	250VAC, 30VDC or less	85 to 242 VAC	5 to 30 VDC	5 to 30 VDC	
Circuit isolation	Mechanical isolation	By photothyristor	By photocoupler	By photocoupler	
Operation indication	LED is lit when relay coil is ON.	LED is lit when Photothyristor is ON.	LED is lit when photocoupler is ON.	LED is lit when photocoupler is ON.	
Maximum load	Resistance load	2A/1 point, 8A/4 points	0.3A/1 point, 0.8A/4 points.	1A/1 point, 3A/4 points	
	Inductive load	80VA	15VA/100VAC 30VA/200VAC	12W/24VDC	24W/24VDC
	Lamp load	100W	30W	1.5W/24VDC	3W/24VDC
Open circuit leak current		1mA/100VAC 2mA/200VAC	0.1mA/30VDC	0.1mA/30VDC	
Minimum load	5VDC, 2mA (reference value)	0.4VA/100VAC 1.6VA/200VAC			
Response time	OFF → ON	Approx. 10msec	2msec max.	0.2msec max.	0.3msec max.
	ON → OFF	Approx. 10msec	12msec max.	1.5msec max.	4msec max.
Input signal current	5mA/24VDC per point (power consumption)	7mA/24VDC per point (power consumption)	7mA/24VDC per point (power consumption)	7mA/24VDC per point (power consumption)	

Outside dimensions

Figure:2.18 Outside dimensions

FX-16E-TB  
 FX-16EY□-TB  
 FX-16EYT-H-TB  
 (□=R, S, T)

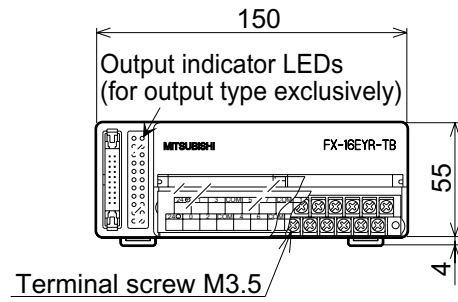

FX-32E-TB

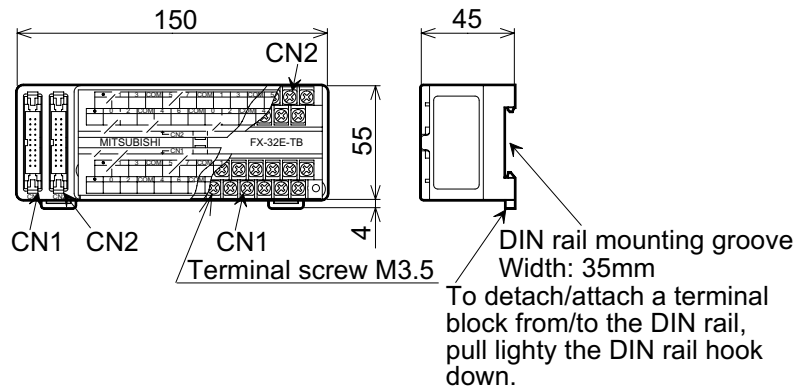



**Figure:2.19 Input wiring**

- The figure below shows an example of the input connection using the FX(E)-20GM and FX-16E-TB terminal blocks.

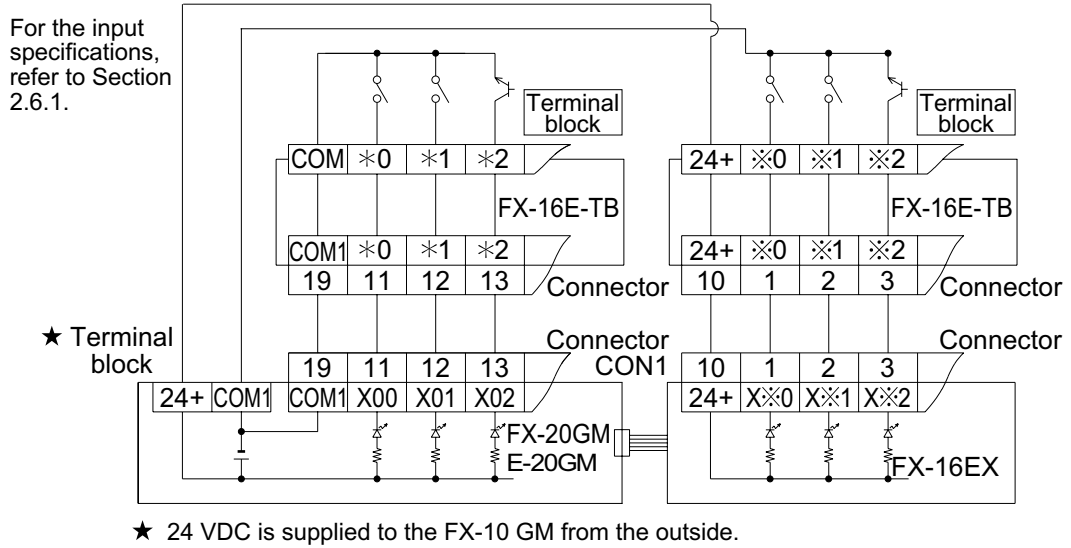

**Figure:2.20 Output wiring**

- The figure below shows an example of the input connection using the FX-16E-TB terminal block.

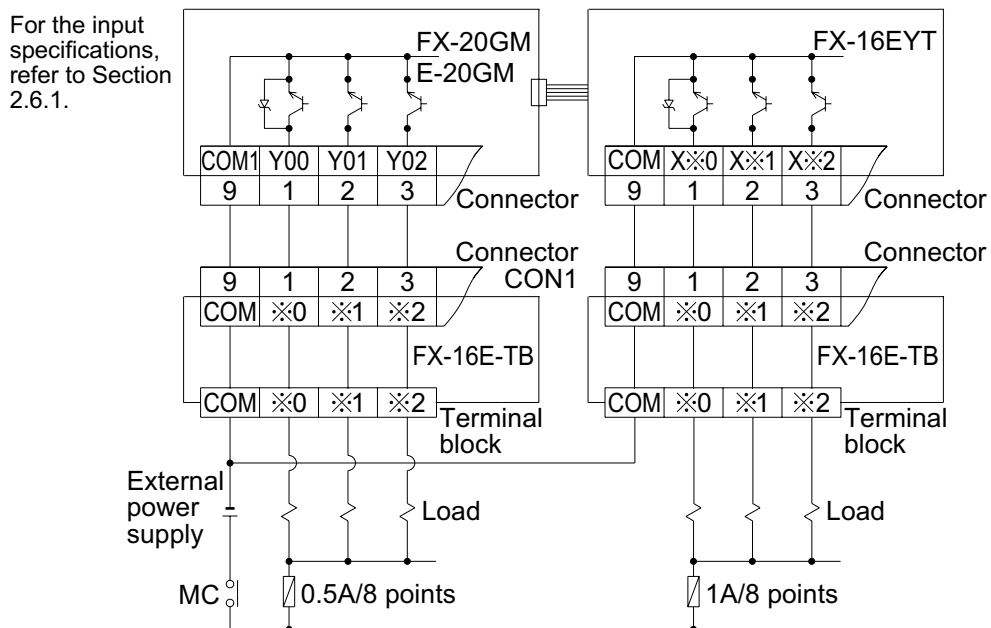

**Terminal block layout**

- The correspondence between the terminal Nos. of the FX-16E-TB I/O terminal block and the pin Nos. of the connector in the FX-10GM, the FX-20GM, the E-20GM, the FX-16EX-C or the FX-16EYT-C is shown below.  
 Note that in the case of the connector in the FX-20GM or the E-20GM, inputs and outputs may be mixed in a variety of combinations and care is required.  
 Note also that if a flat cable is connected, the projections on the connectors must be oriented in one of the ways indicated below.

**Figure:2.21 Terminal block layout**

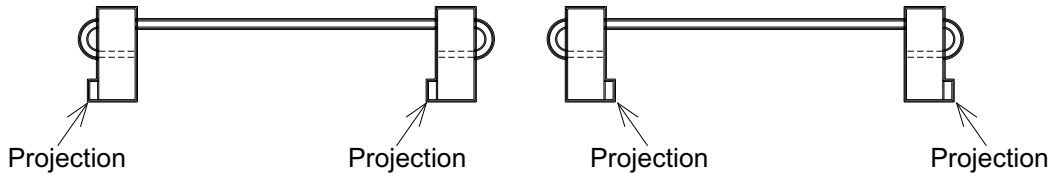

Nos. on insertion side

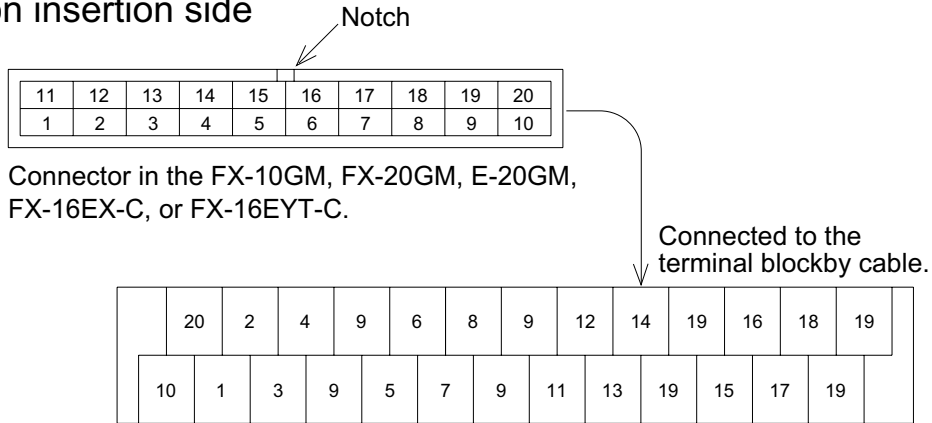

The names of the actual I/O signals of each connector connected to each of the terminals on the terminal block are shown on the next page.  
 An exception is the correspondence when an output terminal block is connected to an FX-16EYT-C extension block, which is shown below.

	24+	Y1	Y3	COM1	Y5	Y7	COM2	Y1	Y3	COM3	Y5	Y7	COM4
	24-	Y0	Y2	COM1	Y4	Y6	COM2	Y0	Y2	COM3	Y4	Y6	COM4

- The figures below indicate the terminal layout when the FX-16E-TB is used.

**Figure:2.22 Terminal block layout**

To CON1 of the FX-10GM  
FX-16E-○○○CAB cable

	Y05	STOP	FWD	COM1	DOG	LSR	COM1	X01	X03	COM1	Y01	Y03	COM1
	Y04	START	ZRN	COM1	RVS	LSF	COM1	X00	X02	COM1	Y00	Y02	COM1

To CON1 of the FX-20GM, E-20GM  
FX-16E-○○○CAB cable

	•	Y01	Y03	COM1	Y05	Y07	COM1	X01	X03	COM1	X05	X07	COM1
	•	Y00	Y02	COM1	Y04	Y06	COM1	X00	X02	COM1	X04	X06	COM1

To CON2 of the FX-20GM, E-20GM  
FX-16E-○○○CAB cable

		y	y	y	y	y	y	x	x	x	x	x	x
	•	STOP	FWD	COM1	DOG	LSR	COM1	STOP	FWD	COM1	DOG	LSR	COM1
		y	y	y	y	y	y	x	x	x	x	x	x
	•	START	ZRN	COM1	RVS	LFS	COM1	START	ZRN	COM1	RVS	LSF	COM1

To CON3 of the FX-20GM, E-20GM  
E-GM-200CAB cable

	x	x	x	x	x	x	x	x	x	x	x	x	x
	ST2	COM2	COM3	COM5	FP	VC	COM5	COM2	COM4	COM5	RP	VC	COM5
	x	x	x	x	x	x	x	x	x	x	x	x	x
	ST1	SVRDY	CLR	COM5	FP0	24Φ	COM5	SVEND	PG0	COM5	RP0	24Φ	COM5

To CON2 of the FX-10GM or CON4 of the FX-20GM/E-20GM  
E-GM-200CAB cable

	y	y	y	y	y	y	y	y	y	y	y	y	y
	ST4	COM6	COM7	COM9	FP	VC	COM9	COM6	COM8	COM9	RP	VC	COM9
	y	y	y	y	y	y	y	y	y	y	y	y	y
	ST3	SVRDY	CLR	COM9	FP0	24Φ	COM9	SVEND	PG0	COM9	RP0	24Φ	COM9

To CON1 of the MR-HA servo amplifier  
E-GMH-200CAB cable

	•	SON	LSP	SG	DI3	•	SG	ZSP	ALM	SG	•	•	SG
	•	EMG	RES	SG	LSN	DI4	SG	VDD	TLC	SG	•	•	SG

To CON1 of the MR-JA servo amplifier  
E-GMJ-200CAB cable

	•	RES	LSN	SG	•	•	SG	ZSP	•	SG	•	•	SG
	•	SON	LSP	SG	•	•	SG	VDD	ALM	SG	•	•	SG

To the FX-16EX-C  
(first extension input)  
FX-16E-○○○CAB  
cable

	24+	X11	X13	•	X15	X17	•	X21	X23	•	X25	X27	•	
	24+	X10	X12	•	X14	X16	•	X20	X22	•	X24	X26	•	

To the FX-16EX-C  
(second extension input)  
FX-16E-○○○CAB  
cable

	24+	X31	X33	•	X35	X37	•	X41	X43	•	X45	X47	•	
	24+	X30	X32	•	X34	X36	•	X40	X42	•	X44	X46	•	

To the FX-16EX-C  
(third extension input)  
FX-16E-○○○CAB  
cable

	24+	X51	X53	•	X55	X57	•	X61	X63	•	X65	X67	•	
	24+	X50	X52	•	X54	X56	•	X60	X62	•	X64	X66	•	

To the FX-16EYT-C  
(first extension output)  
FX-16E-○○○CAB  
cable

	•	Y11	Y13	COM	Y15	Y17	COM	Y21	Y23	COM	Y25	Y27	COM	
	•	Y10	Y12	COM	Y14	Y16	COM	Y20	Y22	COM	Y24	Y26	COM	

To the FX-16EYT-C  
(second extension output)  
FX-16E-○○○CAB  
cable

	•	Y31	Y33	COM	Y35	Y37	COM	Y41	Y43	COM	Y45	Y47	COM	
	•	Y30	Y32	COM	Y34	Y36	COM	Y40	Y42	COM	Y44	Y46	COM	

To the FX-16EYT-C  
(third extension output)  
FX-16E-○○○CAB  
cable

	•	Y51	Y53	COM	Y55	Y57	COM	Y61	Y63	COM	Y65	Y67	COM	
	•	Y50	Y52	COM	Y54	Y56	COM	Y60	Y62	COM	Y64	Y66	COM	

To CN1 of the  
MR-CA servo  
amplifier  
E-GMC-200CAB  
cable

	•	•	LSN	SG	•	•	SG	•	•	SG	•	•	SG	
	•	SON	LSP	SG	•	•	SG	V24	ALM	SG	•	•	SG	

### 2.7.4 I/O extension block

This section explains the connector type extension block. For specifications, refer to Sections 2.6.1 and 2.6.2.

Figure:2.23 I/O extension block

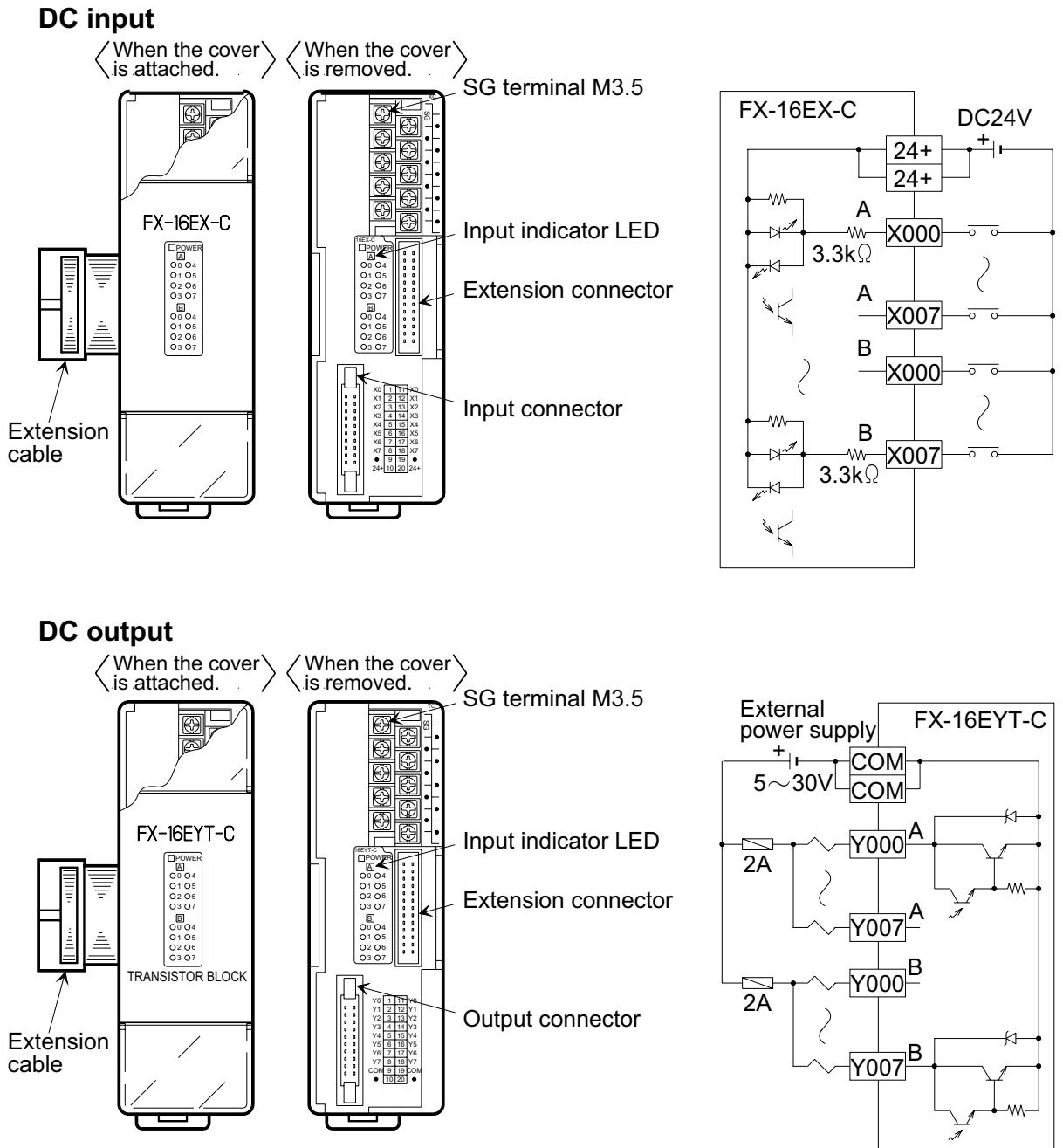

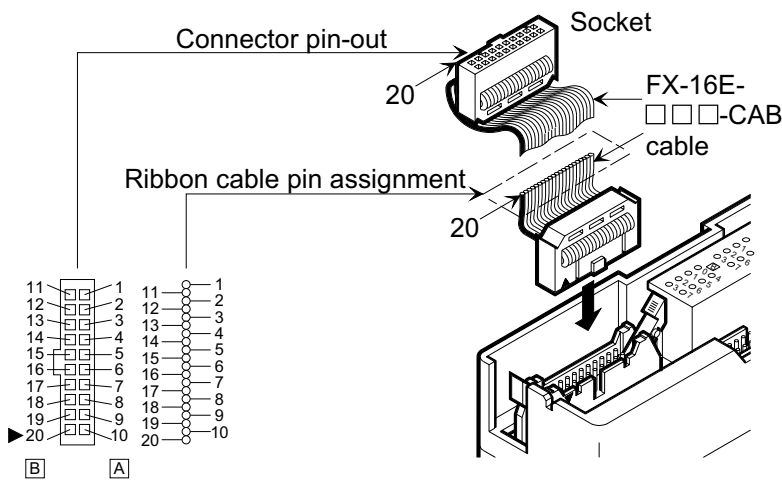

Optional cable

- FX-16E- (See 2.7.1.)

CAB cable.

Applicable connector

(See 2.7.1.)

(Socket pin layout)

FX-16EX-C	Pin No.	1	2	3	4	5	6	7	8	9	10
	Side [A]	X000	X001	X002	X003	X004	X005	X006	X007		24+
	Pin No.	11	12	13	14	15	16	17	18	19	20
	Side [B]	X00	X001	X002	X003	X004	X005	X006	X007		24+

FX-16EYT-C	Pin No.	1	2	3	4	5	6	7	8	9	10
	Side [A]	Y000	Y001	Y002	Y003	Y004	Y005	Y006	Y007	COM	
	Pin No.	11	12	13	14	15	16	17	18	19	20
	Side [B]	Y00	Y001	Y002	Y003	Y004	Y005	Y006	Y007	COM	

Lower numbers are entered on Side [A], and higher numbers are entered on Side [B].

Examples: Side A X040 to X047  
Side B X050 to X057

### **3. OPERATION, MAINTENANCE AND INSPECTION**

This section explains various operations, preparation before operation and maintenance and inspection after operation.

## 3.1 Before Starting Operation

Check the following items before starting operation.

### System design

- Check the machine with regard to the following items to ensure that a suitable motor is selected.  
Load torque, Load inertia, Acceleration/deceleration time,  
Operation speed, Stopping accuracy, Operation frequency, etc.

### Preliminary inspection

Turn OFF the power.

- Incorrect connection of the power supply terminal, contact between a DC input line and a power line, a short-circuit in the output wiring, etc. can cause serious damage. Before turning ON the power, make sure that the power supply and the ground are correctly connected and the I/O lines are correctly wired.

### Remarks

Measure the withstand voltage and the insulation resistance of the positioning unit using the following procedure.

- [1] Disconnect all the I/O wiring and the power line of the positioning unit.
- [2] Connect all the terminals except the ground terminal of the positioning unit with a jumper wire while the positioning unit is not connected to any other unit.
- [3] Measure the voltage and the resistance between the jumper wire and the ground terminal.  
Withstand voltage: 1,500 VAC, 1 minute (FX-20GM, E-20GM)  
500 VAC, 1 minute (FX-10GM)  
Insulation resistance: 5 M or more by 500 VDC Program check.

Turn ON the power, and set the positioning unit to the MANU mode.

- Write a program using a peripheral unit (Release the write-protect switch of the EEPROM in the FX-20GM/E-20GM.)  
After that, read the program and check whether it is correctly written, and check the program and the parameters using the program check function of the peripheral unit.



## 3.2 Operation

This section explains the operations performed by the positioning unit so that you can understand various controls to assure safety.

### 3.2.1 Incremental/absolute drive method

To specify the travel (or rotation angle) of the machine, absolute drive and incremental drive methods can be selected. Absolute drive method indicates the position from a reference point and incremental drive method indicates the position by travel distance from the present position.

#### Absolute drive method

- The distance from the reference point (zero point) is specified.

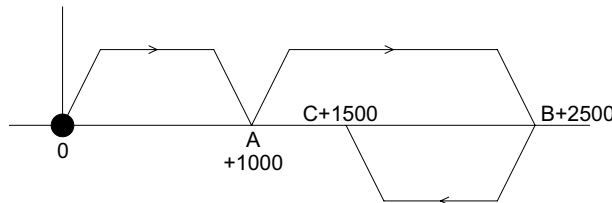

#### Program example

```
Ox00
cod 00 (DRV)
x1000;
cod 00 (DRV)
x2500;
cod 00 (DRV)
x1500;
m02 (END)
```

- In the example above, Point A is placed at "+1000" from the zero point. Point B is placed at "+2500" from the zero point. When the machine returns from Point B to Point C, it moves in the minus direction but the travel is indicated as "+1500". A program example is given.

#### Incremental drive method

- The distance of travel from the present position is specified.

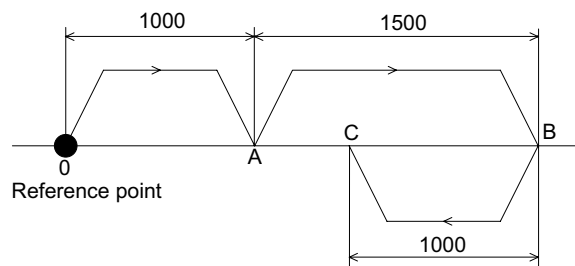

#### Program example

```
Ox00
cod 91 (INC);
cod 00 (DRV)
x1000;
cod 00 (DRV)
x1500;
cod 00 (DRV)
x-1000;
m02 (END)
```

- In the example above, the operation equivalent to that explained in the absolute drive method is indicated. Here, Point A is placed at "+1000" from the initial position. Point B is placed at "+1500" (incremental travel) from Point A (reference point). In the same way, Point C is placed at "-1000" from Point B (reference point).

#### Drive method specification

The absolute drive method can be selected by entering "cod90 (ABS)" in the positioning program, and the incremental drive method can be selected by entering "cod91 (INC)". The absolute drive method is automatically selected when nothing is specified (Refer to Section 5.7.).

### 3.2.2 Direction of motor rotation

This section explains the setting to drive the motor correctly.

Direction of motor rotation

- The direction of motor rotation is determined by the settings of PARA 12 and PARA 15 and by the method used to connect the positioning unit and the drive unit.

**Table:3.1 Direction of motor rotation**

PARA12	Direction of rotation setting "0"	Direction of rotation setting "1"
Present value	Increased by forward rotation pulses (FP) Decreased by reverse rotation pulses (RP)	Decreased by forward rotation pulses (FP) Increased by reverse rotation pulses (RP)
Instruction operations	+x and +y instructions generate forward rotation pulses (FP) -x and -y instructions generate reverse rotation pulses (RP)	+x and +y instructions generate reverse rotation pulses (RP) -x and -y instructions generate forward rotation pulses (FP)
FWD input JOG+input	Generate forward rotation pulses (FP)	Generate reverse rotation pulse (RP)
RVS input JOG-input	Generate reverse rotation pulse (RP)	Generate forward rotation pulses (FP)
Zero return direction	When PARA 15 is set to "0", forward rotation pulses (FP) are generated When PARA 15 is set to "1", reverse rotation pulses (RP) are generated	When PARA 15 is set to "0", reverse rotation pulses (RP) are generated When PARA 15 is set to "1", forward rotation pulses (FP) are generated

- The direction of motor rotation and the direction of machine travel in response to forward rotation pulses depend on the method used to connect the drive unit and the machine specifications.

Connection of limit switches

- Incorrect connection of the limit switches may operate the motor incorrectly.

**Table:3.2 Connection of limit switches**

Type	For stepping motor	For servo motor
LS connection	Connected to positioning unit. Drive unit always ON.	Connected to the drive unit. Positioning unit always ON (refer to remarks below).
LSF	When LSF is turned OFF (refer to note below), input of forward rotation pulses (FP) is stopped and escape is possible using the RVS operation input.	When LSF is turned OFF, forward pulses inside the drive unit are stopped and reverse pulses are accepted.
LSR	When LSR is turned OFF (refer to note below), input of reverse rotation pulses (RP) is stopped and escape is possible using the FWD operation input.	When LSR is turned OFF, reverse pulses inside the drive unit are stopped and forward pulses are accepted.

Note: When PARA 20 is set to "0", input of pulses is stopped when the LS is turned ON.  
When PARA 20 is set to "1", input of pulses is stopped when the LS is turned OFF.

- Install the LSF and the LSR in a position a little outside the usual operation envelope.

Remarks

If driving a servo motor, operation will not be possible unless LSF and LSR are connected to the drive unit and the positioning unit is set to always ON (PARA 20: 1) or always OFF (PARA 20: 0).

However, in this connection status, even if LSF or LSR is actuated and the drive unit stops automatically, the positioning unit will not detect that the drive unit has stopped.

Therefore, it is best to install preliminary limit switches LSF' and LSR' that are actuated before LSF and LSR, and connect these to the positioning unit.

To avoid this double use, connect LSF and LSR to the positioning unit and set the drive unit always to ON, in the same way as the stepping motor connection.

### 3.2.3 Each signal fetch timing

In order to write programs correctly, the writer must be aware of the timing in which the positioning unit detects and executes operations in response to the various inputs.

**Table:3.3 Signal fetch timing**

Input signals	MANU mode		AUTO mode	
	Motor stopped	Motor running	Motor stopped	Motor running
SVRDY	Before drive.	Continuously monitored.	Before drive.	Continuously monitored.
SVEND	After drive.		After drive.	
PGO		After near-point DOG actuation.		After near-point DOG actuation.
DOG	Before zero return drive	During zero return operation.	Before zero return drive	During zero return operation.
START			During READY status.	
STOP, EMS (20GM)	Continuously monitored.			
MANU	Continuously monitored.			
ZRN	Continuously monitored.		During standby after END step.	
FWD, RVS (JOG+, JOG-)	Continuously monitored.		During standby after END step.	
LSF, LSR	Before drive.	Continuously monitored.	Before drive.	Continuously monitored.
X00 ~ X07	When the manual pulse generator is operating.		When the manual pulse generator is operating, During standby after END step.	During execution of INT SINT, DINT instructions
General purpose inputs X00 ~			When the corresponding instruction is executed.	
Inputs specified by parameters.			Continuously monitored.	

\*The special auxiliary relays for command inputs listed in section 4.5.2 are also continuously monitored in the AUTO mode.

**Table:3.4 Functions of operation inputs**

Operation input	Function
MANU (manual)	When the input is ON, MANU (manual) operation is valid. When the input is OFF, AUTO (automatic) operation is valid. Writing and setting of programs and parameters are performed in the MANU mode. In the MANU mode, positioning programs and subtask programs are stopped.
ZRN (machine zero return)	The zero return command is set when the ZRN input changes from OFF to ON, and is reset by the zero return completion signal or STOP command. Become valid during standby after the END step in the MANU or AUTO mode.
FWD (JOG+) (manual forward)	One forward or reverse pulse corresponding to the smallest command unit is generated when the FWD or RVS input is turned ON. If the key is held down for longer than 0.1s, continuous pulses are generated. STOP has priority over these inputs.
RVS (JOG-) (manual reverse)	
STOP	The stop command is set when the STOP input changed from OFF to ON, which stops operation. The settings ("0" to "7") of PARA 23 determines the stop mode used when stopping. In simultaneous 2-axis operation, these inputs are valid simultaneously for both the X and Y axes.
START	The start command is set when the START input changes from OFF to ON in the READY status in the AUTO mode, which starts operation. It is reset by the STOP command, m00 or m02. The STOP command has priority.
EMS (emergency stop)	All operations are stopped and the ERROR LED flashes. Operation is restarted from the beginning of the program when a start command is input after the error has been reset by inputting a STOP command.
STEP (single-step operation)	The single-step mode is established when the STEP input set by parameters is turned ON. Program execution proceeds to the next instruction when the START command is given. Single-step operation is not possible until execution of the instructions in each line N has been completed.

### 3.2.4 Zero return

The positioning unit incorporates a present value register in order to record the absolute position. This is incremented and decremented in accordance with the forward rotation and reverse rotation pulses that it itself generates. This means that the machine position is always known. The present position of the machine must be taught by writing it to this register when operation is started for the first time.

Because the present value register is cleared when the power is turned OFF, the machine zero return operation must always be executed after turning the power ON.

\*Note that this does not apply if an MR-H or MR-J2 servo motor is used because such a motor has a function for counting pulses after the power is turned OFF and a function for retaining the present value, which means that the zero return operation need only be performed once. (Refer to Section 4.4.4.)

#### Independent operation

- The machine zero return operation is performed as follows.
  1. The machine zero return command is given.
  2. The machine travels toward the machine zero return direction specified by PARA 15 at the zero return speed specified by PARA 13.
  3. When the near-point signal (DOG) is turned ON, the machine decelerates to the creep speed specified by PARA 14.
  4. When the zero point signals are counted to the number specified by PARA 17 (after the near-point signal is turned ON), the machine is stopped and the machine zero return operation is completed.

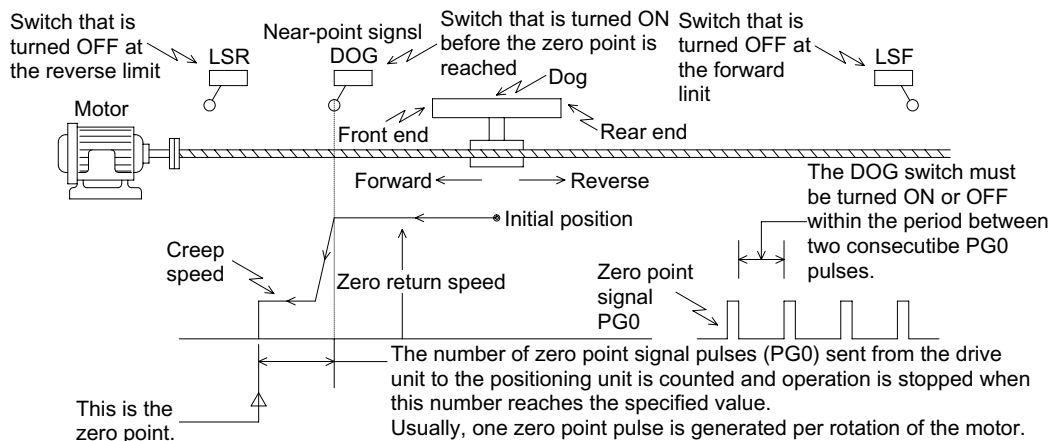

Operation command methods

- The following methods are available to perform machine zero return.
  - ZRN signal entered from an external unit  
(The ZRN signal is entered to each of the X and Y axes in the FX-20GM/E-20GM.)  
 MANU mode: Always valid  
 AUTO mode: Valid during m02 (END) standby
  - During execution of cod28 (DRVZ) (Refer to Section 5.4 for the FX-20GM/E-20GM.)  
 MANU mode: Invalid  
 AUTO mode: During execution of instruction
  - Commands sent from a subtask  
 Turn ON M9004 (X axis) and M9020 (Y axis) while the subtask is in the AUTO mode.  
 MANU mode: Invalid
  - Commands sent from the programmable controller (Not applicable to the E-20GM)  
 Turn ON the buffer memories #20 b4 (X axis) and #21 b4 (Y axis).  
 MANU mode: Always valid.  
 AUTO mode: Valid during m02 (END) standby
- The figure below shows the relationship between the parameters and the special data registers while the machine zero return operation is performed.

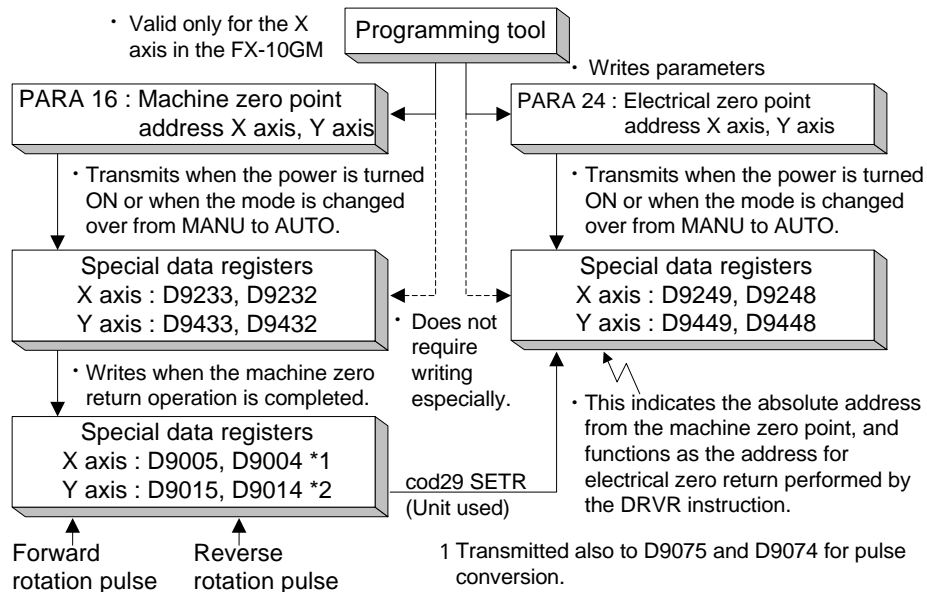

- When the machine zero return operation is completed, the special auxiliary relays M9057 (X axis) and M9089 (Y axis) are actuated. (If the machine zero return command is issued again, these relays become ineffective once, then are actuated again when the zero return operation is completed.) These special auxiliary relays are not held after a power interruption.
- The relays M9057 and M9089 remain actuated when the mode is changed over from MANU to AUTO after the machine zero return operation is performed in the MANU mode.

Reference	Special auxiliary relays:	Section 4.5.2.
	Zero return instruction:	Section 5.4.
	Special data registers:	Section 4.5.3.

### Operation examples

- The following four methods are available for the machine zero return operation depending on the design of the DOG (width from the front end to the rear end) and the DOG switch.
- |   |   |
|---|---|
| <p>[1] Method used to avoid installation of a DOG switch (Operation example 1).<br/>Forward and reverse travel can be executed in manual operation. When the system is stopped, the present position can be set as the machine zero position by using push-button commands.</p>   | <p>[3] Method used when it is possible to set the DOG width greater than the motor deceleration to creep distance (Operation example 3). Deceleration is started when the front end of the DOG reaches the DOG switch, and the zero point signal count is started when the rear end of the DOG reaches the DOG switch .<br/>Since the zero point signal count starts after the creep speed has been attained, this method makes adjustment of the DOG switch actuation point easier. The DOG search function is executed in the same way as described in [2].</p> |
| <p>[2] Method used when the DOG width must be as small as possible (Operation example 2).<br/>In order to make it easier to adjust the point at which the DOG switch operates, the zero return speed must be set as slow as possible. If the zero return command is given at a position after the DOG has passed the DOG switch, the machine first travels until the reverse limit switch is actuated, then travels forward until the machine has passed the DOG switch, then travels in the reverse direction again to return to the zero point. This is called the DOG search function.</p> | <p>[4] Method used when the DOG switch is a long way from the reverse limit switch and the DOG search operation would take too long (Operation example 4).<br/>If the DOG width is increased so that the DOG switch remains ON after completion of the zero return operation, another zero return operation can be performed using this as a basis.</p>   |

### Operation example 1

When installation of a DOG switch must be avoided.

- Set PARA 18 to "2 (mode without DOG)", and return the machine to the zero point manually.
- Move the machine to the specified position using the FWD and RVS buttons. When the machine is stopped, press the ZRN button.
- Then, the CRL signal is issued and the deviation counter of the servo amplifier is cleared.
- The zero point address set to PARA 16 is written in the present value register.
- This operation need only be performed once when the absolute drive method is selected using the MR-H/MR-J2 servo motor.

Operation example 2

When the DOG width must be as small as possible.

- If the ZRN input is turned ON in the MANU mode or the DRVZ instruction is executed in the AUTO mode, a machine zero return operation will be executed.
- The zero return speed, the zero return direction, the deceleration time, the creep speed, etc. are set by parameters.
- Deceleration is started when the front end of the DOG reaches the DOG switch, and the zero signal count is started when either the front end or the rear end of the DOG reaches the DOG switch. (The setting of PARA 18 determines the start timing.)
- When the PG0 count value reaches the specified value (set to PARA 17), travel is stopped, the clear signal (CLR) is issued, and the zero point address (set to PARA 16) is written to the present value register.

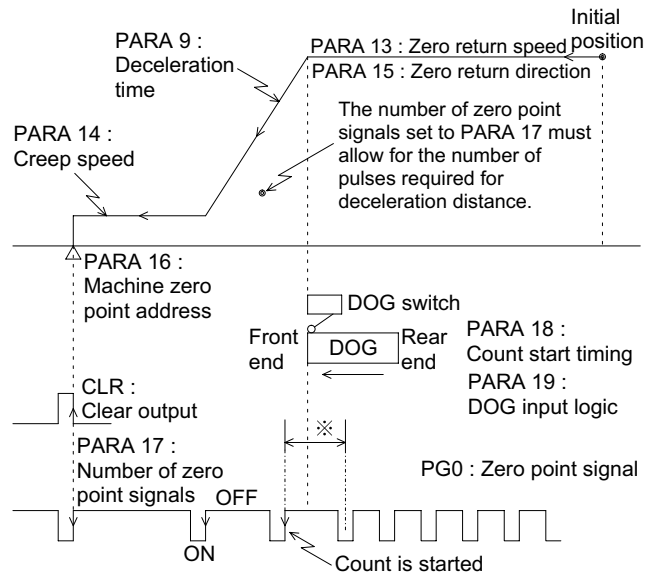

\*Adjust to ensure that the DOG switch actuation point is within the period between two consecutive PG0 pulses. In order to make adjustment easier, the zero return speed must be made as low as possible.

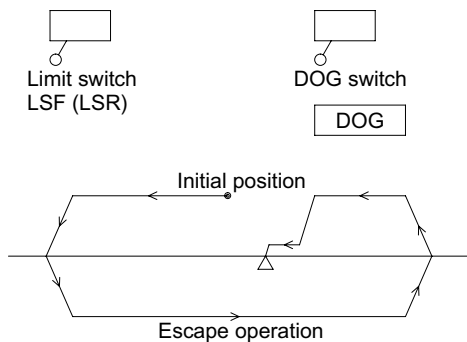

- If a zero return operation is executed when the DOG has already passed the DOG switch and is stopped, the machine first travels until the limit switch is actuated and then reverses the direction and executes the zero return operation again.
- The limit switches and the DOG switch used can be either the normally open type or the normally closed type (The type can be set by parameters.).
- If the limit switches LSR and LSF are not connected to the positioning unit, the escape operation must be performed manually.

Operation example 3

When it is possible to set the DOG width greater than the motor deceleration to creep distance

- If the ZRN input is turned ON in the MANU mode or when the DRVZ instruction is executed in the AUTO mode, a machine zero return operation will be executed.
- The zero return speed, the zero return direction, the deceleration time, the creep speed, etc. are set by parameters.
- Set the parameters so that deceleration starts when the front end of the DOG reaches the DOG switch and the zero signal count is started when the rear end of the DOG reaches the DOG switch.
- When the PG0 count value reaches the specified value (set to PARA 17), travel is stopped, the clear output (CLR) is issued, and the zero point address (set to PARA 16) is written to the present value register.

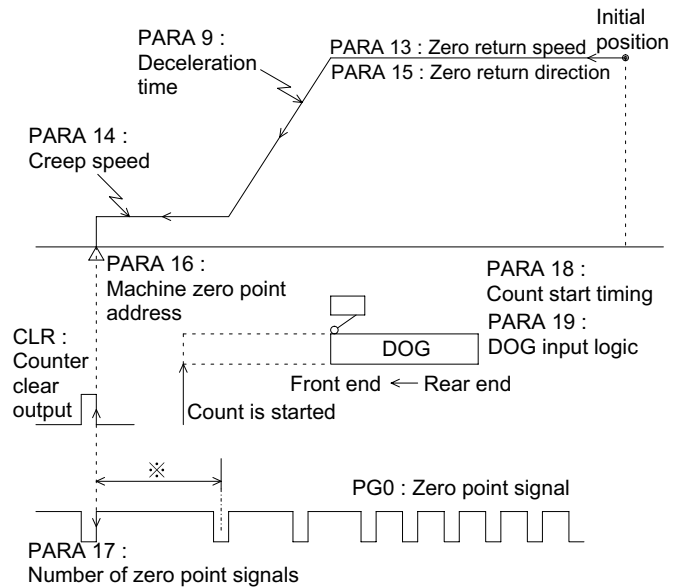

\*Adjust to ensure that the DOG switch actuation point is within the period between two consecutive PG0 pulses. The DOG width must be wider than the machine deceleration distance.

Dog search function

The DOG search is performed in the same way as described on the previous page, using a limit switch.



Operation example 4

When the DOG switch is a long way from the reverse limit switch and the DOG search operation would take too long

- If the ZRN input is turned ON in the MANU mode or the DRVZ instruction is executed in the AUTO mode, a machine zero return operation will be executed.
- The zero return speed, the zero return direction, the deceleration time, the creep speed, etc. are set by parameters.
- Set the parameters so that deceleration and the zero signal count are started when the front end of the DOG reaches the DOG switch.
- When the PG0 count value reaches the specified value, travel is stopped, the clear output (CLR) is issued, and the zero point address (set to PARA 16) is written to the present value register.

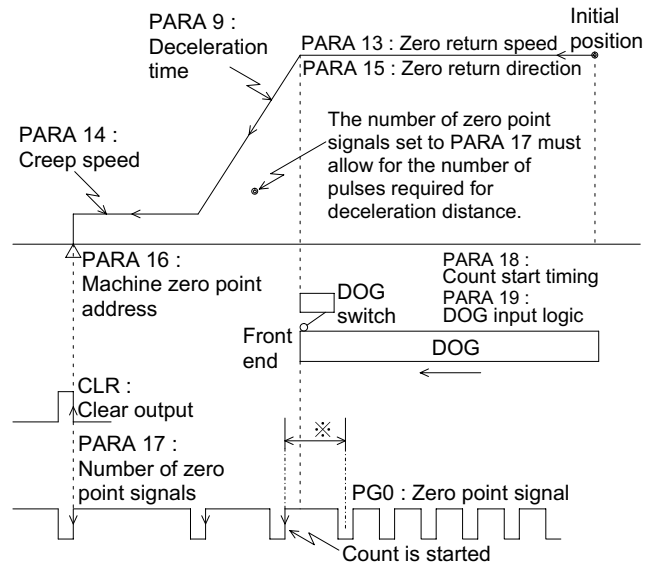

\*Adjust to ensure that the DOG switch actuation point is within the period between two consecutive PG0 pulses. In order to make adjustment easier, the zero return speed must be made as low as possible.

DOG search function

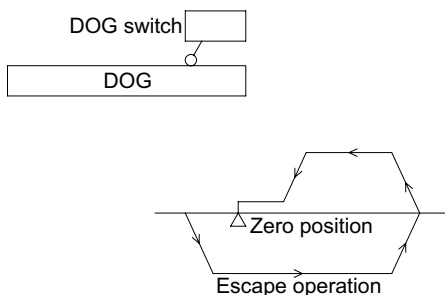

- If the DOG is in contact with the DOG switch even after completion of a zero return operation, the system will automatically escape from this situation before performing the zero return operation.
- Automatic escape is also possible when the limit switches are connected to the servo amplifier and not to the positioning unit.

### 3.2.5 JOG operation

This section explains the manual forward and reverse operations.

#### Outline of operation

- One forward or reverse pulse corresponding to the smallest command unit is generated when the FWD (manual forward) or RVS (manual reverse) input signal is turned ON. If the key is held down for longer than 0.1 s, pulses are generated continuously.

#### Operation methods

- The following methods are available to perform manual forward/reverse operation.
- FWD/RVS signal entered from an external unit.  
(The FWD/RVS input signal is entered to each of the X and Y axes in the FX-20GM/E-20GM.)  
MANU mode: Always valid  
AUTO mode: Valid during m02 (END) standby
- Commands sent from a subtask (while the subtask is in the AUTO mode).  
(\*Valid only for the X axis in the FX-10GM.)  
Turn ON M9005 (X axis, FWD) and M9021 (Y axis, FWD) or M9006 (X axis, RVS) and M9022 (Y axis, RVS).  
MANU mode: Always valid  
AUTO mode: Valid during m02 (END) standby.
- Commands sent from the programmable controller (Not available in the E-20GM). (\*Valid only for the X axis in the FX-10GM.)  
Turn ON #20 b5 (X axis, FWD) and #21 b5 (Y axis FWD) or #20 b6 (X axis, FWD) and #21 b6 (Y axis, FWD).  
MANU mode: Always valid  
AUTO mode: Valid during m02 (END) standby

#### Operation example

- Both the external inputs and the commands sent from the programming tool become valid by OR processing in the positioning unit.

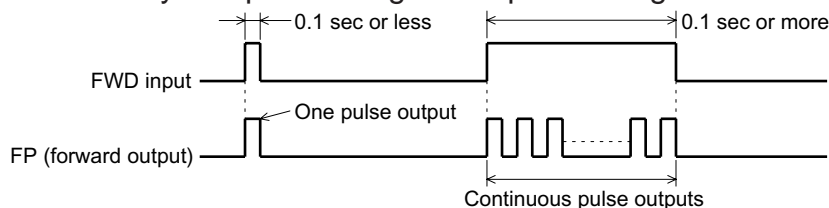

- The positioning unit performs the following operations in response to the command inputs.  
The RVS input also generates the RP (reverse input).
- The pulse output speed can be set by PARA 5 (jog speed).
- The generated pulses are added to or subtracted from the present value register, and saved in D9005 and D9004 for the X axis and D9015 and D9014 for the Y axis.
- In the jog operation, the positioning completion signals (M9049: X axis, M9081: Y axis) are not turned ON after the pulse outputs are finished. Check the READY/BUSY signal (M9048: X axis, M9080: Y axis) to confirm completion of the operation. (When the unit is in the ready status, M9048 and M9080 are ON.)

### 3.2.6 Single-step operation

This section explains single-step operation.

#### Outline of operation

- Every time the start input is entered while the single-step command is turned ON, the positioning program is executed by one line.

#### Operation methods

- PARA 53 must be set to "1 (single-step operation valid)" to perform the single-step operation.
- The following methods are available to perform the single-step operation.
- Turn ON the input set by PARA 54 (single-step mode input No.).  
MANU mode: Invalid  
AUTO mode: Always valid
- Commands sent from a subtask (while the subtask is in the AUTO mode).  
(Valid only for the X axis in the FX-10GM.)  
Turn ON M9000 (X axis) and M9001 (Y axis).
- Commands sent from the programmable controller  
Turn ON #20 b0 (X axis), #21 b0 (Y axis) and #27 b0 (subtask).  
MANU mode: Invalid  
AUTO mode: Always valid

#### Operation example

- The following operations are performed in response to the commands entered.

#### Program example

```
Ox00
  }
N0000 cod28
(DRV)x1000 m10;
  }
N0200 m02 (END);
```

- While the single-step command input is ON, the program is executed one line every time the start command is turned ON. The next start command input is not accepted until positioning is completed.
- In the line N0000, the next command input is not accepted until machine zero return is completed.
- The program including M codes does not accept the next command input until positioning is completed and the M code OFF signal sent from the programmable controller is turned ON.

### 3.2.7 Automatic operation

This section explains the automatic operation.

#### Outline of operation

- The positioning programs (and subtask program) are executed in automatic mode.

#### Operation instruction input

- The following operation commands are offered to execute the positioning programs. Each of these commands can be accepted in the AUTO mode.
- START ON command entered from an external unit.
- Commands sent from a subtask (while the subtask is in the AUTO mode). Turn ON M9001 (X axis) and M9017 (Y axis).
- Commands sent from the programmable controller (Not available in the E-20GM). Turn ON #20 b1 (X axis) and #21 b1 (Y axis).

\*The subtask start timing is determined by the setting of PARA 104 (subtask start).

#### Operation example

- The following operations are performed in response to the command inputs.

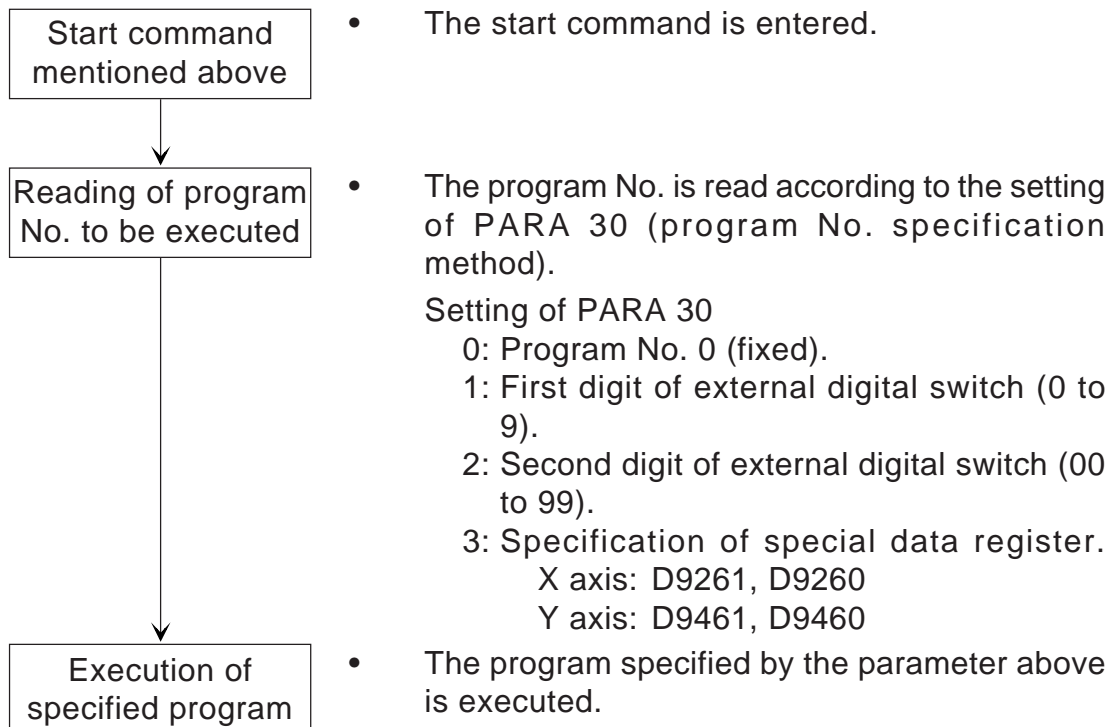

## 3.3 Troubleshooting

When an error has occurred first, check whether or not the supply voltage is correct and whether or not loose terminal screws or imperfect contact of connectors can be found on the positioning unit or the I/O units.

### 3.3.1 Troubleshooting using LEDs

The error condition can be found by checking the status of the various LEDs provided on the positioning unit.

**Figure:3.1 LED names**

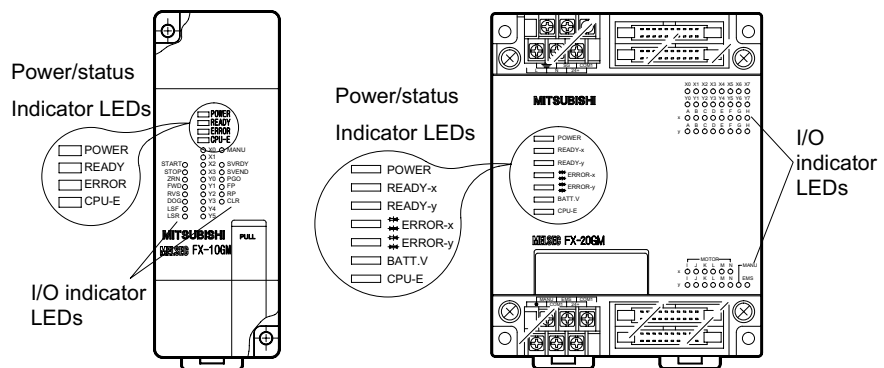

#### Power indication

##### "POWER" LED OFF

- If the POWER LED is not lit when the power is turned ON, disconnect the connectors connecting various I/O units. If the POWER LED is lit correctly with the connectors disconnected,
  - [1] The 24 VDC service power supply exceeds its capacity (with the FX/E-20GM).  
Refer to Section 2.5.2 and check the capacity.
- With the FX/E-20GM, a fuse inside the unit may be blown out when conductive objects have entered or another error has occurred. In this case, replacement of the fuse is not sufficient. Contact the Mitsubishi Service Center.

#### Ready status

##### "READY" LED OFF

- The READY LED is lit without regard to the mode (MANU or AUTO) while the positioning unit is ready for accepting various operation commands (Refer to Section 3.2.3.).  
If the READY LED is OFF,
  - [1] While positioning is performed (pulses are being output).  
Enter the stop command or change over the mode from AUTO to MANU to stop the operation and light this LED.
  - [2] When an error has occurred.  
Check the reason for the error, and remove the cause.

## Error indication

### "ERROR" LED lit

- When an error has occurred during operation, the ERROR LED is lit or flashes. In this case, read the error code using a peripheral unit, refer to "3.3.2 Error list" to find the reason for the error, then remove the cause. The common errors are as follows.
  - [1] Parameter error
    - Error code: 2004 (maximum speed)
    - If the unit system adopted is the mechanical system, the setting can be 200 kPPS or more when converted into pulses.
  - [2] Program error
    - Error code: 3000 (no program No.)
    - This error occurs when an attempt is made to execute a program whose program No. does not exist. Monitor PARA 30 (program No. specification) as well as D9261/D9260 (X axis) and D9461/9460 (Y axis) to make sure that a correct program No. is specified.
  - [3] Program error
    - Error code 3001 (no m02 (END) command)
    - "m02 (M102 in a subtask)" is not programmed at the end of the program specified to be executed.
  - [4] External error
    - Error code: 4004 (limit switch actuation)
    - Check PARA 20 (limit switch logic).

## CPU error

### "CPU-E" LED lit

- If the CPU-E LED is lit when the power of the positioning unit is turned ON in MANU mode, a watchdog timer error has occurred. In this case, check whether the battery voltage is low, whether abnormal noise sources are present, or whether inductive foreign objects are present. It is recommended to perform Class 3 grounding (Grounding resistance: 100  $\Omega$  or less) of as short a distance as possible using a wire of 2 mm<sup>2</sup> or more as described in Section 2.

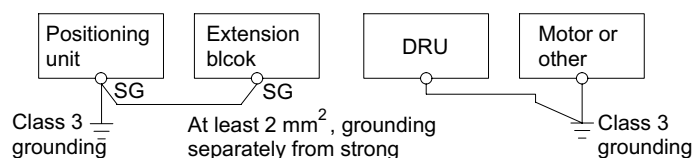

**BATT.V**

"BATT V" LED lit      FX-20GM, E-20GM

- If the battery voltage is low, the BATT V LED is lit by the 5 V power supply when the power is turned ON; the special auxiliary relay M9143 is actuated. When approximately 1 month has passed after low battery voltage is detected and the BATT V LED lit, programs (when RAM memory is used) and various memories backed up by the battery cannot be held during power interruptions. Make sure the battery is replaced soon.

Remarks

- While the special relay M9127 is driven, this LED is not lit even if the battery voltage is low. The special auxiliary relay M9143 is still actuated.
- When data registers are used for set values, the contents of the data registers could become unstable and the set values could be changed when the battery voltage is low; even if the EEPROM is used as the program memory. Be careful.
- The FX-10GM is a batteryless unit and incorporates EEPROM memory.

**I/O indication**

LED for Various I/O indication

- If an I/O indicator LED does not flash when the input switch is turned ON and OFF, check the input wiring of the positioning unit. Especially, check if the input switch connections are secure, if the input switch cannot be turned OFF because the input switch is in parallel with another line, etc. If the load does not turn ON or OFF when an output indicator LED flashes, check the output wiring. Especially, the output transistor of the positioning unit may be damaged by a short-circuited load or an excessive load.

Pulse output indication

- The pulse output indicator LEDs (L and M in the FX-20GM/E-20GM, and FP and RP in the FX-10GM) usually seem to be lit dimly during normal operation status (while pulses are output) because they are flashing at a high frequency.
- The LEDs are alphabetically labeled on the FX-20GM/E-20GM. The relationship between the alphabetic indication and the functions is shown below.

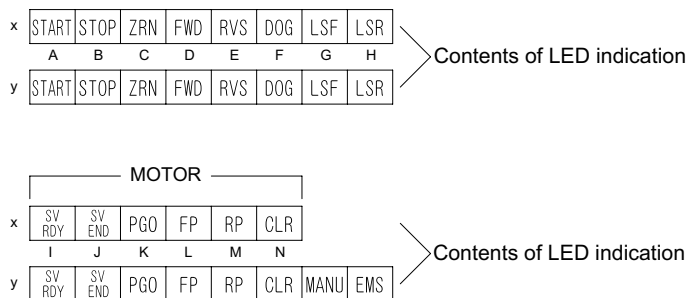

## 3.4 Maintenance

### Periodical maintenance

- Most of the parts incorporated in the positioning unit will never need to be replaced. However, the service life of the battery is approximately 5 years (The guaranteed period is 1 year.), and it should be replaced periodically using the following procedure. Purchase batteries when they are required. The FX-10GM is batteryless, and programs and parameters are saved in built-in EEPROM.
- Also check the following items when inspecting other equipment.
  - Is the temperature inside the panel abnormally high due to heat radiating bodies in the vicinity or to direct sunlight?
  - Has any dust or conductive material entered inside the panel?
  - Are there any loose or rusted terminals, or damaged wires?

### Replacement of battery

- If the battery voltage is low, the BATT.V LED on the front panel is lit when the power is turned ON. Although memory data will be retained for approximately 1 month after this LED is lit for the first time, the battery should be replaced as soon as possible and power should be kept ON as much as possible until it is replaced.  
Note that even if an EEPROM cassette is used as the program memory, the battery is still required to protect data saved in battery-backed memory.

### Battery replacement procedure

- [1] Turn OFF the power of the FX-20GM/E-20GM.
- [2] Lift up the upper part of the panel cover using your fingertips or the blade of a screwdriver, and open the cover.
- [3] Remove the old battery from its holder and remove the connector.
- [4] Insert the connector of a new battery immediately (within 30 sec. after removal of the old battery).
- [5] Fit the new battery into the holder and attach the panel cover.

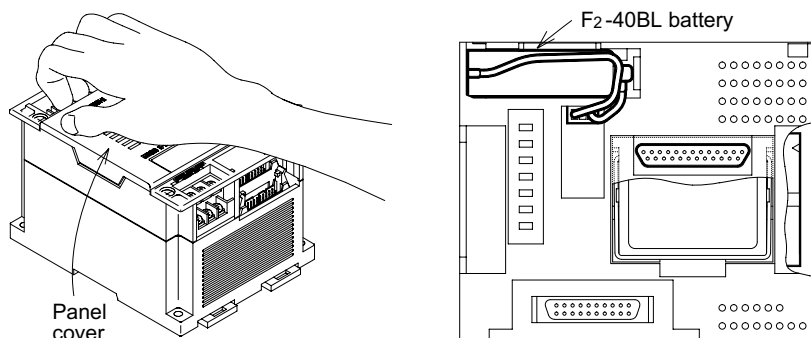



### 3.5 Error Code List

When any of the errors shown below occur, the ERROR-x or ERROR-y LED on the front panel of the positioning unit is lit. Note that the LED will flash if any of the external errors shown in the table below occur. Also note that in the case of error code 9002 the CPU-E LED will be lit.

- Confirmation of error  
The error code can be confirmed by monitoring the error with an E-20TP teaching panel or FX-PCS-KIT/GM personal computer software or by using the special auxiliary relays (M) and special data registers (D) shown in the table below. When an FX/FX2C Series programmable controller is connected, the error code can be checked in the programmable controller by reading the buffer memory (BFM) with the FROM instruction.

**Table:3.5 Confirmation of error**

	Error detection		Error code	
	Special M	BFM	Special D	BFM
X axis	M9050	#23 <b3>	D9061	#9061
Y axis	M9082	#25 <b2>	D9081	#9081
Subtask	M9129	#28 <b1>	D9102	#9102
Operation	Turns ON when an error is detected.		Saves the error code.	

\*The Y axis is not defined in the FX-10GM.

- Error resetting method  
The error can be reset by removing the cause of the error and performing the following operation.
  - Perform an error reset operation with a peripheral unit such as the E-20TP, the personal computer software, etc. (For details, refer to the appropriate manual.)
  - Set the operation mode to MANU and give the STOP command (by turning ON the input terminal [STOP] or the special M).
  - Turn ON the special M or the BFM shown in the table below.

**Table:3.6 Error resetting method**

	Error reset	
	Special M	BFM
X axis	M9007	#20 <b7>
Y axis	M9023	#21 <b7>
Subtask	M9115	#27 <b3>

\*The Y axis is not defined in the FX-10GM.

• Error code list

**Table:3.7 Error code list**

Error category	Error code	Details	Reset	Simultaneous 2-axis mode	Independent 2-axis mode
System parameter setting errors	1100 to 1111	If one of the parameters 100 to 111 has been set incorrectly, the corresponding error code 1100 to 1111 is displayed.	Make sure that the parameter setting evaluated as error is within the set range.	Global error	Global error
Parameter setting errors	2000 to 2056	If one of the positioning parameters 0 to 24 or the I/O control parameters 30 to 56 is set incorrectly, the corresponding error code 2000 to 2056 is displayed.		Local error	Local error
Program error	3000	Program No. does not exist. When the start command is given in the AUTO mode, the specified program No. does not exist.	Change the program No. or create the program (Refer to Section 5.1.).	Global error	
	3001	"m02(END)" is not provided in the program. The m02 (END) command is not provided at the end of the specified program.	Add "m02 (END)" at the end of the specified program (Refer to Section 5.1.).		
	3002	---	---	Local error	Local error
	3003	Set value register overflow			
	3004	Set value fault			
	3005	Instruction format error	Program the label for the call/jump destination.	Global error	
	3006	No label for call or jump			
	3007	Call instruction fault			
	3008	Repeat instruction fault			
3009	O/N/P No. error An O/N/P No. outside the set range is specified.	Only programs for simultaneous 2-axis or programs for independent 2-axis must be present (Refer to page 5-2.).	Global error	Global error	
3010	Axis setting fault Programs for simultaneous 2-axis (O) and programs for independent 2-axis (Ox, Oy) are mixed together.				
External errors (LED flashes.)	4000	---	---		
	4001	---			
	4002	Servo end error The positioning completion signal is not received from the motor amplifier.	Check PARA 21 and the wiring (Refer to pages 4-13 and 2-22.).	Local error	Local error
	4003	Servo ready error The preparation completion signal is not received from the motor amplifier.	Check PARA 22 and the wiring (Refer to pages 4-14 and 2-22.).		
	4004	Limit switch actuated	Check PARA 22, check the limit logic, then check the wiring.		
	4005	EM-STOP actuated (in the E/FX-20GM only)	Short-circuit the [EMS] and [COM1] external terminals.	Global error	Global error
4006	ABS data transfer error	Check the parameter and the wiring (Refer to pages 2-23 and 4-22.).	Local error	Local error	
Critical error	9000	Memory error	If the same error occurs again even after turning OFF and ON the power, repair is required. Contact the Mitsubishi Service Center.	Global error	Global error
	9001	Sum check error			
	9002	Watchdog timer error (CPU-E LED is lit.)			
	9003	Hardware error			
No. error	0000	No. error	---	---	---

**Table:3.8 Error code list**

	Simultaneous 2-axis mode	Independent 2-axis mode
Global error	Regardless of whether an X axis Y axis error has occurred, both axes stop and the ERROR indication is performed for both axes.	Same as left
Local error	The ERROR indication is performed for the axis in which the error has occurred, and axes are stopped.	The ERROR indication is performed for the axis in which the error has occurred, and axis is stopped.

\*Only one axis is provided in the FX-10GM, and the axis is stopped when an error has occurred.

# MEMO

## 4. PARAMETERS AND SPECIAL DEVICES

Three types of parameters (system parameters, positioning parameters and I/O control parameters) are used to set the operating conditions of the positioning unit. The positioning unit can satisfy many requirements by initially setting these parameters according to operation and control specifications.

The settings of special auxiliary relays and special data registers must also be read and written according to the required control.

### 4.1 Notes on Parameters in General

The parameters are initial settings required for positioning control. Based on the settings of the parameters, the positioning unit is controlled by the positioning programs.

Types of parameters

The parameters are classified into the following three types.

- Positioning parameters (PARA. 0 ~)  
Determine the units, the speed, etc. for positioning control.
- I/O control parameters (PARA. 30 ~)  
Determine the contents related to the I/Os of the positioning unit such as the method of specifying the program No., the destination of the M code, etc.
- System parameters (PARA. 100 ~)  
Determine the memory size of the program, the number of file registers, etc.

In the FX(E)-20GM, the positioning parameters and the I/O control parameters for independent 2-axis operation must be set for each of the X and Y axes. The parameters for simultaneous 2-axis operation need only be set for the X axis. The settings for the Y axis are not required. In the FX-10GM, the parameters must be set for one axis (the X axis) exclusively.

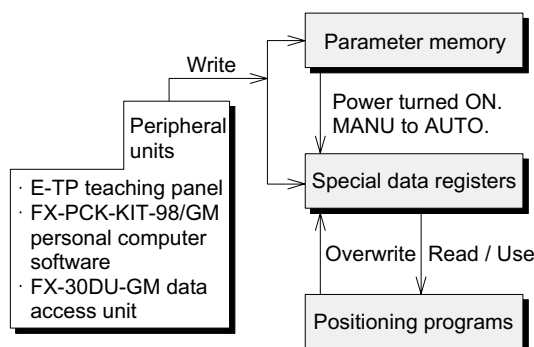

- With some exceptions, each parameter is assigned a special data register (special D).
- When parameters are set from the panel of a peripheral unit, the same data is simultaneously set in the special Ds.
- The data in the special Ds can be changed using the positioning program during operation. Operation is then performed in accordance with the changed data.
- However, when power is turned ON, the special Ds are initialized with the held data in the parameter memories. This also happens when the mode is changed over from MANU to AUTO.

Continued on the next page.

Reference Positioning parameters: Section 4.3  
Special data registers: Section 4.6

I/O control parameters: Section 4.2  
System parameters: Section 4.2

- When a value beyond the allowed range of a parameter is entered, the positioning unit performs the following operation.

[ Parameter written using a peripheral unit ]

A parameter set error (Error code: 2000 to 2056) occurs, and the positioning unit stops.

When this error occurs, the ERROR-x and/or ERROR-y LEDs provided on the panel of the positioning unit are lit.

A correct value must be written to the parameter to reset the error status.

[ Parameter written using a positioning program ]

Though the positioning unit does not stop, the parameter is set to the following value.

When the entered value is larger than the effective range:

A parameter related to time or speed is set to the maximum value.

When the entered value is smaller than the effective range:

A parameter related to time or speed is set to the minimum value.

## 4.2 System Parameters

The system parameters set the positioning program memory size, the number of file registers, the battery status and items related to subtasks.

### 4.2.1 Basic parameters

Set the basic parameters which determine the memory size, the number of file registers and the battery status.

Setting the memory size.

#### PARAM. 100: Memory size

Set the program memory size.

Setting for the FX(E)-20GM		Setting for the FX-10GM	
Setting = "0" : 8K steps	Initial value	Setting = "1" : 4K steps	Initial value
Setting = "1" : 4K steps		Initial value : 1	

- The program memory consists as follows.

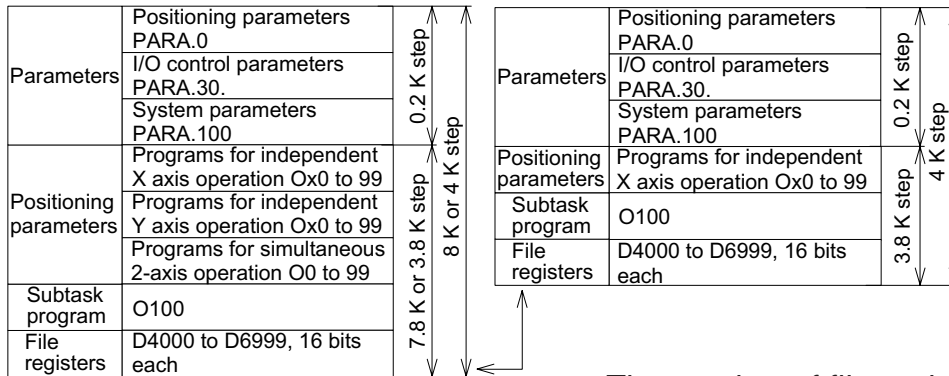

- The number of file registers used is set by PARA. 101 described below.

Setting the file registers

#### PARAM. 101: File registers

Set the number of points used for file registers. One point requires one step of program memory. Serial numbers beginning with D4000 are valid as the file register Nos.

Setting for the FX(E)-20GM		Setting for the FX-10GM	
Setting : 0 to 3000	Initial value	Setting : 0 to 3000	Initial value
	D4000 to D6999		D4000 to D6999

Setting the battery status

**PARA. 102: Battery status**

Set whether or not the LED on the front panel is lit and a warning signal is issued when the voltage of the F<sub>2</sub>-40BL battery inside the 20GM becomes low.

Setting for the FX(E)-20GM				Setting for the FX-10GM
Setting	LED	GM output	M0127	Not applicable
0	ON	No output	OFF	
1	OFF	No output	ON	
2	ON	Output set in PARA. 103 set ON.	OFF	

**PARA. 103: Battery status output No.**

Set the output No. in the 20GM when PARA. 102 is set to "2".

Setting for the FX(E)-20GM	Setting for the FX-10GM
Setting = Output relay (Y) No. in a range of 0 to 67. Initial value=0	Not applicable



### 4.2.2 Subtask parameters

The following settings are required when subtasks are used. These set values are ignored when subtasks are not used.

Subtask start.

#### PARAM. 104: Subtask start

Set the subtask start command timing.

Setting for the FX(E)-20GM	Setting for the FX-10GM
Setting = "0": Starts a subtask when the mode is changed from MANU to AUTO (initial value)	Setting = "0": Starts a subtask when the mode is changed from MANU to AUTO (initial value)
Setting = "1": Starts a subtask when the input specified by PARA.105 is turned ON.	Setting = "1": Starts a subtask when the input specified by PARA.105 is turned ON.
Setting = "2": Starts a subtask when the mode is changed from MANU to AUTO or when the input specified by PARA.105 is turned ON.	Setting = "2": Starts a subtask when the mode is changed from MANU to AUTO or when the input specified by PARA.105 is turned ON.

#### PARAM. 105: Subtask start input No.

Set the subtask start input No. when PARA. 104 is set to "1" or "2".

Setting for the FX(E)- 20GM	Setting for the FX-10GM
Setting = Input relay (X) No. in a range of 0 to 67 372 to 377	Setting = Input relay (X) No. in a range of 0 to 3 375 to 377
Initial value = 0	Initial value = 0

#### PARAM. 106: Subtask stop

Set the subtask stop command timing.

Setting for the FX(E)-20GM	Setting for the FX-10GM
Setting = "0": Stops a subtask when the mode is changed from AUTO to MANU (initial value).	Setting = "0": Stops a subtask when the mode is changed from AUTO to MANU (initial value).
Setting = "1": Stops a subtask when the input specified by PARA.107 is turned ON or when the mode is changed from AUTO to MANU.	Setting = "1": Stops a subtask when the input specified by PARA.107 is turned ON or when the mode is changed from AUTO to MANU.

#### PARAM. 107: Subtask stop input No.

Set the subtask stop input No. when PARA. 106 is set to "1".

Setting for the FX(E)- 20GM	Setting for the FX-10GM
Setting = Input relay (X) No. in a range of 0 to 67 372 to 377	Setting = Input relay (X) No. in a range of 0 to 3 375 to 377
Initial value = 0	Initial value = 0

Subtask start/stop configuration diagram

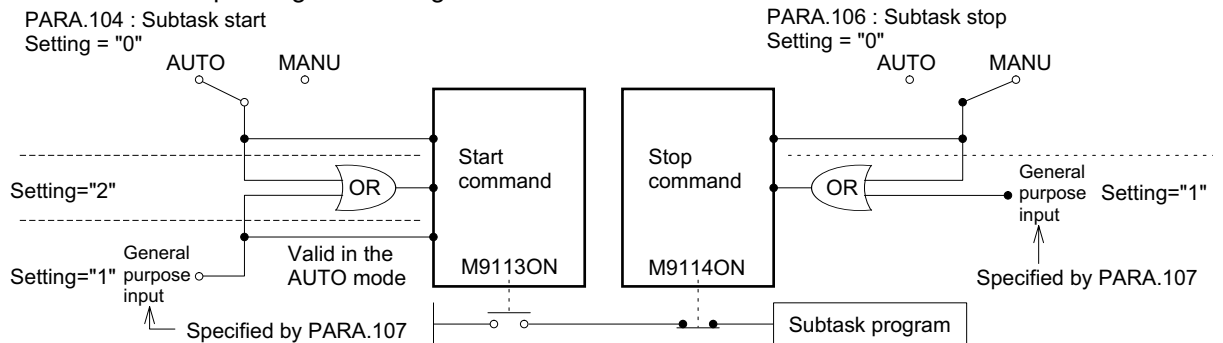

Subtask error

**PARA. 108: Subtask error**

Set whether or not the positioning unit outputs an error when the error occurs in the subtask.

Setting for the FX(E)-20GM	Setting for the FX-10GM
Setting = "0": Does not output from the positioning unit when an error occurs (initial value).	Setting = "0": Does not output from the positioning unit when an error occurs (initial value).
Setting = "1": Outputs from the positioning unit when an error occurs.	Setting = "1": Outputs from the positioning unit when an error occurs.

**PARA. 109: Subtask error output**

Set the output device No. when PARA. 108 is set to "1".

Setting for FX(E)-20GM	Setting for FX-10GM
Setting = Output (Y) No. in a range of 0 to 67 Initial value : 0	Setting = Output (Y) No. in a range of 0 to 5 Initial value : 0

- When an error occurs in the subtask, M9129 is turned ON. The error can be reset by turning ON M9115.

Subtask single-step/cyclic operation mode

**PARA. 110: Subtask single-step/cyclic operation**

Set the operation mode (single-step or cyclic) of the subtask.

Single-step: Executes one program line every time the start input is turned ON.

Cyclic: Executes the program to the end (marked by "m102") when the start input is turned ON, then automatically stops execution.

Continuous cyclic operation can be executed by jumping to the head of the subtask program using the unconditional jump instruction.

Setting for the FX(E)-20GM	Setting for the FX-10GM
Setting = "0": Does not use the general purpose input (initial setting). Performs single-step operation when M9112 is set in the program, and performs cyclic operation when M9112 is reset in the program.	Setting = "0": Does not use the general purpose input (initial setting). Performs single-step operation when M9112 is set in the program, and performs cyclic operation when M9112 is reset in the program.
Setting = "1": Uses the general purpose input. Changes over between single-step operation and cyclic operation by the specified input M9112.	Setting = "1": Uses the general purpose input. Changes over between single-step operation and cyclic operation by the specified input M9112.

**PARA. 111: Subtask single-step/cyclic operation input**

Enter the input device No. when PARA. 110 is set to "1".

Single-step operation is performed when the input device specified by this parameter is turned ON.

Setting for the FX(E)- 20GM	Setting for the FX-10GM
Setting = Input relay (X) No. in a range of 0 to 67 372 to 377 Initial value = 0	Setting = Input relay (X) No. in a range of 0 to 3 375 to 377 Initial value = 0

## 4.3 Positioning Parameters

This section explains the parameters which control positioning such as the units, the speed, etc.

(For the initial values, refer to Section 4.3.5.)

### 4.3.1 Units

Setting the units used

#### PARAM. 0: System of units

Set the units used for the position and the speed.

	Setting for the FX(E)-20GM	Setting for the FX-10GM
	Setting = "1": Controls the position based on "PLS" (pulses), which is called the motor system of units (initial value).	Setting = "1": Controls the position based on "PLS" (pulses), which is called the motor system of units (initial value).
	Setting = "0": Controls the position based on "mm, deg, 1/10 inch, etc.", which is called the mechanical system of units.	Setting = "0": Controls the position based on "mm, deg, 1/10 inch, etc.", which is called the mechanical system of units.
This mode is recommended. →	Setting = "2": Controls the position using the mechanical system of units and the speed using the motor system of units, which is called the combined system of units.	Setting = "2": Controls the position using the mechanical system of units and the speed using the motor system of units, which is called the combined system of units.

In accordance with the setting of PARA. 0, the parameters are expressed in the units shown in the table below.

PARAM. No.	system of units.	"0": Mechanical	"1": Motor	"2": Combined	
PARAM. No.1, No.2		Setting required	Ignored	Setting required	PARA. 1 and PARA. 2 must be set when the mechanical system of units or the combined system of units is used.
PARAM. No.3		mm, deg, 1/10 inch	PLS	mm, deg, 1/10 inch	
PARAM. No.4, No.5, No.6, No.13, No.14		cm/min, 10 deg/min, inch/min	PLS/sec	PLS/sec	

↑ Refer to "Important information" shown below.

#### PARAM. 3: Minimum command unit

Set the unit of travel specified by the positioning program.

Setting in FX(E)-20GM and FX-10GM	PARAM. No.3	Set value "0": Mechanical system of units. Set value "2": Combined system of units.			Set value "1": Motor system of units.
		mm	deg	inch	
Initial value →	Set value : "0"	10 <sup>0</sup>	10 <sup>0</sup>	10 <sup>-1</sup>	10 <sup>3</sup>
	Set value : "1"	10 <sup>-1</sup>	10 <sup>-1</sup>	10 <sup>-2</sup>	10 <sup>2</sup>
	Set value : "2"	10 <sup>-2</sup>	10 <sup>-2</sup>	10 <sup>-3</sup>	10 <sup>1</sup>
	Set value : "3"	10 <sup>-3</sup>	10 <sup>-3</sup>	10 <sup>-4</sup>	10 <sup>0</sup>

"cod 00(DRV) x1000 y2000" indicates "x" of 10 mm and "y" of 20 mm.

"cod 00(DRV) x1000" indicates "x" of 10000 pulses.

#### Important information

- Concept of machine units  
When PARA. 0 (system of units) is set to "0" or "2", the mechanical system of units including "mm, deg, 1/10 inch", etc. is used. In this case, all the parameters shown in the table above use the same unit.



**4.3.2 Speed, acceleration/deceleration, etc.**

This section explains the speed, the acceleration/deceleration, etc., when various positioning operations are performed. The items related to the zero return operation such as the zero return speed and the creep speed are explained in the next section.

**Operation speed**

Set the maximum speed, the jog speed and the bias speed within the specified range as follows.

**PARA. 4: Maximum speed**

Set the maximum speed in this parameter. When the speed is not specified in a positioning program, the machine operates at the speed set here. Other speeds must be set to a value equivalent to or less than this maximum value.

200 kPPS or less when converted into pulses	Setting for the FX(E)-20GM	Setting for the FX-10GM
	Mechanical system: 1 to 153,000 (cm/min, x10deg/min, inch/min) Motor system : 1 to 200,000 PPS	

**PARA. 5: Jog speed**

Set the speed for manual operation (by FWD/RVS input ON or JOG+/- operation from a peripheral unit).  
Set a value equivalent to or less than the value set to PARA. 4 above.

**PARA. 6: Bias speed (Invalid during interpolation)**

Set the speed adopted when the system is started.

20 kPPS or less when converted into pulses	Setting for the FX(E)-20GM	Setting for the FX-10GM
	Mechanical system: 1 to 153,000 (cm/min, x10deg/min, inch/min) Motor system : 1 to 200,000 PPS	

**Acceleration/deceleration time**

**PARA. 8: Acceleration time**

Set the time required to achieve the maximum speed.

**PARA. 9: Deceleration time**

Set the time required to stop the machine.

Setting for the FX(E)-20GM	Setting for the FX-10GM
0 to 5000ms	

**Interpolation time constant**

**PARA. 10: Interpolation time constant**

Set the time required to achieve the speed specified by the program. (The bias speed is always regarded as "0".) This parameter is valid while interpolation control is performed in the FX(E)-20GM.

Setting for the FX(E)-20GM	Setting for the FX-10GM
0 to 5000ms	

In the FX-10GM, acceleration/deceleration time is set to the value set in this parameter when the cod 01/ cod 31 command is used.

Reference Initial values: Section 4.3.5

- The operation speed in the mechanical system of units can be converted into a value in the motor/combination system of units using the following formula.

$$\text{Speed command value} \times \frac{\text{PARA.1 (A) (PLS/REV)}}{\text{PARA.2 (B) } (\mu\text{m/REV, mmdeg/REV, minch/REV} \times 10^{-1})} \times \frac{10^4}{60}$$

cm/min  
 ( 10 deg/min )  
 inch/min

Unit matching  
 200,000 or 20,000 PLS/sec  
 In the case of PARA. 6  
 In the case of PARA. 4/5

- The parameters explained on the previous page have the relationship shown in the figure below.

Cod 00/28/30/71/72:Manual operation.

When the cod 01/02/03/31 instruction is used, the bias speed is always set to "0".

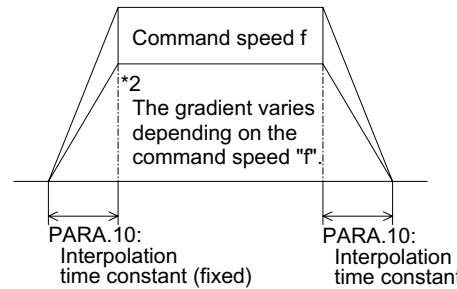
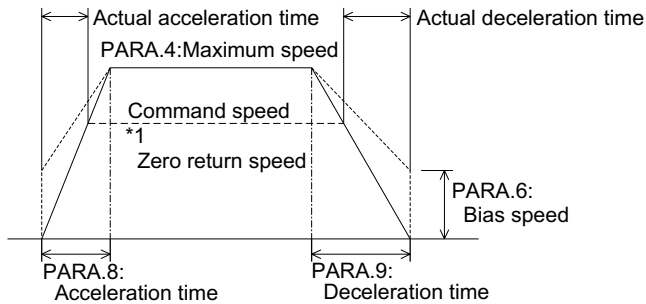

- \*1 The acceleration time indicates the time required to achieve the maximum speed. Accordingly, when all of the command speed, the zero return speed and the jog speed are equivalent to or less than the maximum speed, the actual acceleration time becomes shorter.
- \*2 The interpolation time constant is always fixed while interpolation control is performed. Accordingly, the gradient of acceleration/deceleration varies depending on change in the command speed. If the speed is not specified, "100 kPPS" is automatically set to the 20GM and "200 kPPS" to the 10 GM. In the 10GM, multistep speed operation is performed (Refer to page 5-13).

Compensation

**PARA. 7: Backlash compensation (Valid exclusively for the cod 00 instruction.)**

When the rotation direction is reversed by the cod 00 (DRV) instruction, the compensation quantity set to this parameter is automatically added to the travel quantity, then positioning is performed. However, the compensation quantity is not added to the present value register.

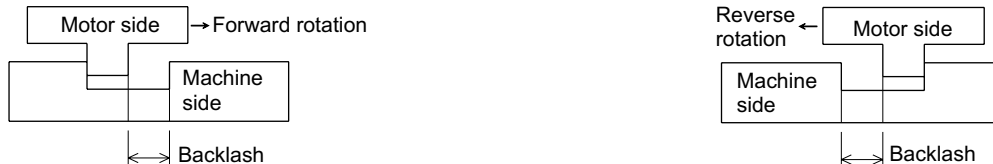

- Other compensations as follows can be performed in the positioning program.
  - Cod 73 (MOVC) : Travel compensation,
  - Cod 74 (CNTC) : Center point compensation,
  - Cod 75 (RADC) : Radius compensation,
  - Cod 76 (CANC) : Cancel of compensation (except the backlash).

### 4.3.3 Machine zero return, etc.

This section explains the parameters required to perform the machine zero return.

Machine zero return, etc.

#### **PARA. 13: Zero return speed**

Set the speed adopted when the machine is returning to the zero point. The set value must be equivalent to or less than the maximum speed set to PARA. 4.

20 kPPS or less when converted into pulses	Setting for the FX(E)-20GM	Setting for the FX-10GM
	Mechanical system: 1 to 153,000 (cm/min, x10deg/min, inch/min) Motor system : 1 to 200,000 PPS	

#### **PARA. 14: Creep speed**

Set the low speed adopted after the near-point DOG signal is turned ON.

20 kPPS or less when converted into pulses	Setting in the FX(E)-20GM	Setting in the FX-10GM
	Mechanical system: 1 to 153,000 (cm/min, x10deg/min, inch/min) Motor system : 1 to 20,000 PPS	

#### **PARA. 15: Zero return direction**

Set the direction in which the machine travels when the zero return instruction is given.

Setting for the FX(E)-20GM	Setting for the FX-10GM
Setting = "0" : Direction in which the present value increases. Setting = "1" : Direction in which the present value decreases.	

#### **PARA. 16: Machine zero point address**

Set the present address at which the machine is placed when the zero return operation is completed.

Setting for the FX(E)-20GM	Setting for the FX-10GM
-999,999 to +999,999	

The units of the set value are determined by PARA. 0 and PARA. 3. The value set here is treated as an absolute address. Set this parameter to "0" when absolute position detection (ABS) is performed.

#### **PARA. 17: Zero point signal count**

Set the number of zero point signals to be counted after the DOG switch input is turned ON or OFF (The count timing is set by PARA. 18.) until the machine is stopped. One zero point signal pulse is output per rotation of the motor (in the case of a servo motor) in general.

Setting for the FX(E)-20GM	Setting for the FX-10GM
0 to 65,535	

#### **PARA. 18: Zero signal count start timing**

Set the point at which the zero signal count is started.

Setting for the FX(E)-20GM	Setting for the FX-10GM
Setting = "0": When the front end of the near-point dog reaches the DOG switch (OFF to ON). Setting = "1": When the rear end of the near-point dog reaches the DOG switch (ON to OFF). Setting = "2": When the near-point dog is not used.	

Reference Initial values: Section 4.3.5

**PARA. 19: DOG switch input logic**

Set the DOG switch input logic.

Setting for the FX(E)-20GM	Setting for the FX-10GM
Setting = "0" : Normally open. (The DOG switch is closed at the near-point.)	Setting = "0" : Normally open. (The DOG switch is closed at the near-point.)
Setting = "1" : Normally closed. (The DOG switch is opened at the near-point.)	Setting = "1" : Normally closed. (The DOG switch is opened at the near-point.)

**PARA. 20: Limit switch logic**

Set the logic of the limit switch (LS) used to confirm the machine operation limit. Apart from the limit switches, software limits (set by PARA. 25 and PARA. 26) are also available.

Setting for the FX(E)-20GM	Setting for the FX-10GM
Setting = "0" : Normally open. (The limit switch is closed at the limit.)	Setting = "0" : Normally open. (The limit switch is closed at the limit.)
Setting = "1" : Normally closed. (The limit switch is opened at the limit.)	Setting = "1" : Normally closed. (The limit switch is opened at the limit.)

Outline of zero return

- The parameters set on the previous page relate to the Machine parts shown in the figure below. For details of the zero return operation, refer to "5.4 Zero Return Control Instructions".

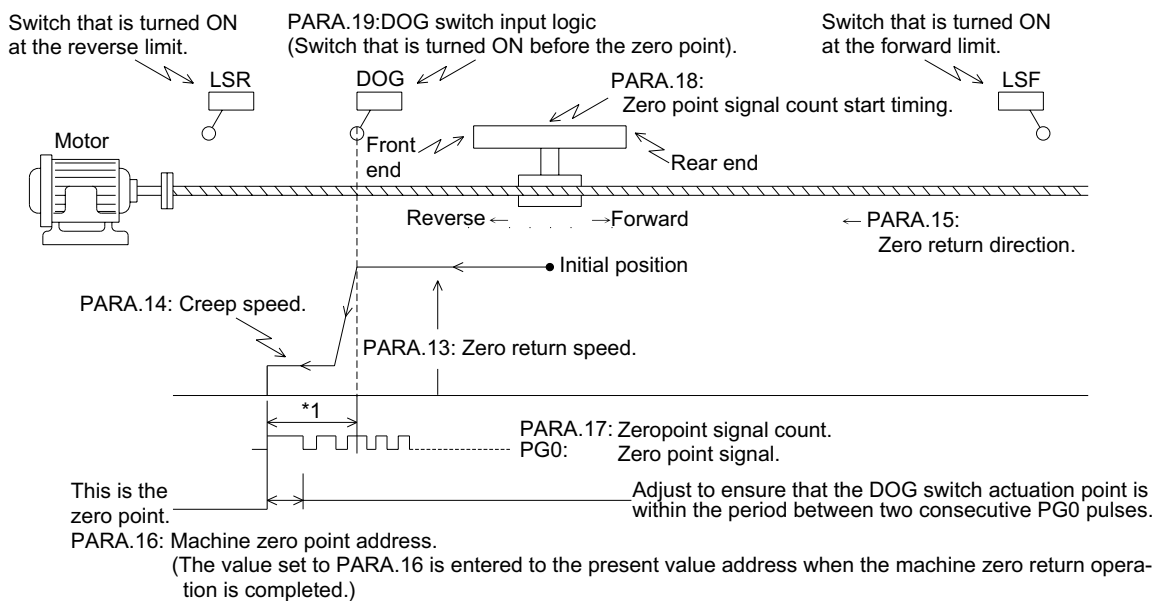

\*1 The number of zero point signal pulses (PG0) sent from the drive unit to the positioning unit is counted, and operation is stopped when this number reaches the specified value. Usually, one zero point pulse is generated per rotation of the motor.

The machine zero return command can be given by either of the following four methods.

- [1] Turning ON an external input (from the [ZRN] terminal).
- [2] Executing the cod 28 (DRVZ, machine zero return) command.
- [3] Sending the machine zero return command from a peripheral unit.
- [4] Turning ON the special auxiliary relay (M9008 for the X axis and M9024 for the Y axis).



### 4.3.4 Other settings

This section explains other various positioning parameters.

Pulse format

#### PARA. 11: Pulse output format

Set the pulse output format for the drive unit.

Setting for the FX(E)-20GM	Setting for the FX-10GM
Setting = "0": Forward rotation pulses and reverse rotation pulses.	Setting = "1": Rotation pulses and direction specification (Interpolation operations are not possible). Refer to figures below for the pulse format.

The LED on the positioning unit is lit when the pulse waveform is at the L level (when the transistor is ON).

Setting = "0"	Setting = "1"
FP = forward rotation pulses. RP = reverse rotation pulses.	PLS = rotation pulses. SIGN = direction specification.

#### PARA. 12: Rotation direction

Set the rotation direction of the motor.

Setting for the FX(E)-20GM	Setting for the FX-10GM
Setting = "0": The present value increases when forward rotation pulses (FP) are output.	Setting = "1": The present value decreases when forward rotation pulses (FP) are output.

Servo ready/servo end check

#### PARA. 21: Positioning completion error evaluation time

If the positioning completion signal is not entered within the time set to this parameter when output of pulses is finished, a servo end error occurs. When the servo end check instruction (cod 09 (CHK)) or an instruction (cod 00 (DRV), cod 28 (DRVZ), etc. For details, refer to Section 5.) which automatically performs the servo end check is executed, evaluation is performed within the set time. When "0" is set to this parameter, the servo end check is not performed.

Setting for the FX(E)-20GM	Setting for the FX-10GM
0 to 5000 msec (When set to "0", the servo end check is not performed).	

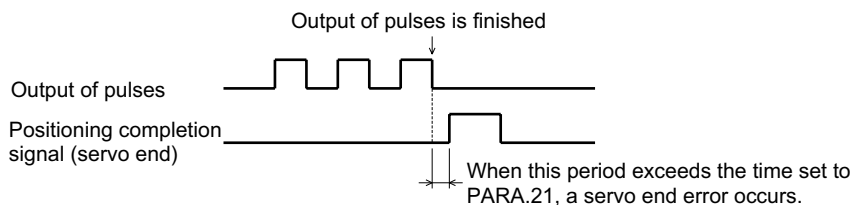

- In the case of a motor without the positioning completion signal, always turn ON the servo end signal in the wiring (by short-circuiting the [SVEND] and [COM] terminals. For details, refer to Section 2.) or set PARA. 21 to "0"

Reference Initial values: Section 4.3.5



Electrical zero point address

**PARA. 24: Electrical zero point address**

Set the absolute address for electrical zero return executed by the cod 30 (DRVR) instruction.

Setting for the FX(E)-20GM	Setting for the FX-10GM
-999,999 to +999,999	

The unit is determined by PARA. 0 and PARA. 3. The address set by PARA. 24 represents an absolute value.

Software limit

**PARA. 25: Software limit (upper)**

**PARA. 26: Software limit (lower)**

When the present value becomes equal to or more than the set value, a limit error occurs.

When the present value becomes equal to or less than the set value, a limit error occurs.

Setting for the FX(E)-20GM	Setting for the FX-10GM
Set a 32-bit value within the following range. -2,147,483,648 to +2,147,483,647	

- When the software limit is reached, the machine is immediately stopped in the same way as a stop caused by the limit switches (limit error).
- The software limit becomes valid after a zero return operation or an absolute position detection is performed. After either operation is performed, the present value establish flags M9144 (for the X axis) and M9145 (for the Y axis) are turned ON (The M9144 only is turned ON in the 10GM.).
- When the value set to PARA. 25 is equal to or less than the value set to PARA. 26, the software limit function is invalid.
- When a limit error occurs, the error code 4004 is actuated. Jog operation in the opposing direction is possible even in the error status. When the machine is returned from an area beyond the limit position, the error is reset.
- In the FX(E)-20GM, the software limit is valid in Ver. 2.00 or later. In an E-20TP unit of Ver. 1.11 or former, PARA. 25 and PARA. 26 are displayed as spare. Set desired values.

### 4.3.5 Default values (initial values)

The positioning parameter values set in the factory are shown in the table below as "For servo motors". These values are also written in the system ROM of the E-20TP and the personal computer software as default values. (The vales for stepping motors are shown for reference.) You can read these values, correct them in accordance with your application, then transmit the corrected values to the positioning unit.

**Table:4.1 Default values (initial values)**

PARA No.	Description	Basic parameters				Remarks
		For servo motors		For stepping motors		
		20GM	10GM	20GM	10GM	
0	System of units	1	1	1	1	Motor system of units
1	Pulse rate	2,000	*12,000	500	500	Not used.
2	Feed rate	2,000	*2,000	2,000	2,000	Not used.
3	Minimum command unit	2	2	2	2	10 PLS
4	Maximum speed	200,000	200,000	5,000	5,000	PLS/sec
5	Jog speed	20,000	20,000	1,000	1,000	PLS/sec
6	Bias speed	0	0	250	250	PLS/sec
7	Backlash compensation	0	0	0	0	PLS
8	Acceleration time	200	200	100	100	msec
9	Deceleration time	200	200	100	100	msec
10	Interpolation time constant	100	100	100	100	msec
11	Pulse output format	0	0	0	0	Forward rotation pulses and reverse rotation pulses.
12	Rotation direction	0	0	0	0	The present value increases by forward rotation pulses.
13	Zero return direction	100,000	100,000	2,500	2,500	PLS/sec
14	Creep speed	1,000	1,000	500	500	PLS/sec
15	Zero return direction	1	1	1	1	Direction in which the present value decreases.
16	Machine zero point address	0	0	0	0	PLS
17	Zero point signal count	1	1	1	1	1 times
18	Zero point signal count start timing	1	1	1	1	Count is started when the rear end of the DOG reaches the DOG switch.
19	DOG switch input logic	0	0	0	0	Normally open contact.
20	Limit switch logic	0	0	0	0	Normally open contact.
21	Error evaluation time	0	0	0	0	The servo end check is not used.
22	Servo ready check	1	1	1	1	Not used.
23	Stop mode	1	1	1	1	The remaining distance drive is valid.
24	Electrical zero point address	0	0	0	0	PLS
25	Software limit (upper)	0	0	0	0	The software limit is not used.
26	Software limit (lower)	0	0	0	0	

\*1 This is the number of command pulses per rotation of the motor (PLS/REV), and is invalid for the motor system of units.

\*2 This is the travel quantity per rotation of the motor ( $\mu\text{m}/\text{REV}$ ,  $\text{mdeg}/\text{REV}$ ,  $0.1 \text{ minch}/\text{REV}$ ), and is invalid for the motor system of units.

## 4.4 I/O Control Parameters

This section explains the settings of the parameters to read the program No., output the M code and detect the absolute position by utilizing the general purpose I/Os of the positioning unit.

### 4.4.1 Program No.

This section explains the settings of the parameters to specify the program No. to be executed.

Program No.

#### PARA. 30: Program No. specification method

Set the program No. specification source. The program No. can be specified from the positioning unit or the programmable controller.

Setting for the FX(E)-20GM	Setting for the FX-10GM
Setting = "0": The program No. is fixed to "0".	
Setting = "1": The program No. consisting of one digit is specified in a range "00" to "09" by an external digital switch.	
Setting = "2": The program No. consisting of two digits is specified in a range "00" to "99" by an external digital switch.	
Setting = "3": The program No. is specified by the special data registers (D). (To specify the program No. from the programmable controller use this setting.)	
*The program No. is set by D9000 (for simultaneous 2-axis or the X axis (including the 10GM)) and D9001 (Y axis).	

[ Specification by the digital switch (DSW) ]

When PARA. 30 is set to "1" or "2", the following parameters must be set. (These parameters are invalid when PARA. 30 is set to "0" or "3".)

#### PARA. 31: Head input No. for DSW time-sharing reading

Specify the head input No. of the four input points (1, 2, 4 and 8) for the DSW data.

Setting for the FX(E)-20GM	Setting for the FX-10GM
X0 to 67 X372 to 374	X0 to 3

#### PARA. 32: Head output No. for DSW time-sharing reading

Specify the output destination for the DSW data.

Setting for the FX(E)-20GM	Setting for the FX-10GM
Y0 to Y67	Y0 to Y5

When PARA. 30 is set to "1", one output point is occupied.  
When PARA. 30 is set to "2", two output points are occupied.

#### PARA. 33: DSW reading interval

Set the interval during which the DSW data is read (ON time of the output set by PARA. 32).

Setting for the FX(E)-20GM	Setting for the FX-10GM
7 to 100 msec (increment: 1 msec)	

Important information

When PARA. 30 is set to "2", attach 50 V, 0.1 A diodes to the digital switch to prevent revolving paths.

Example of DSW connection

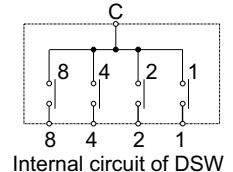
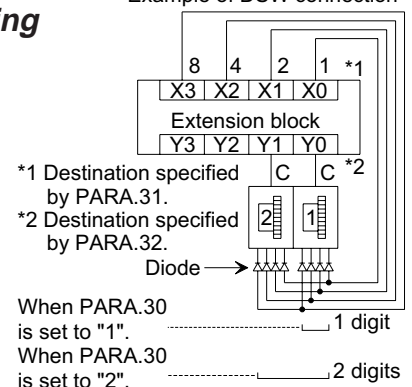

- The DSW data to specify the program No. to be executed is automatically read immediately after the START command is given even if the EXT instruction is not given.

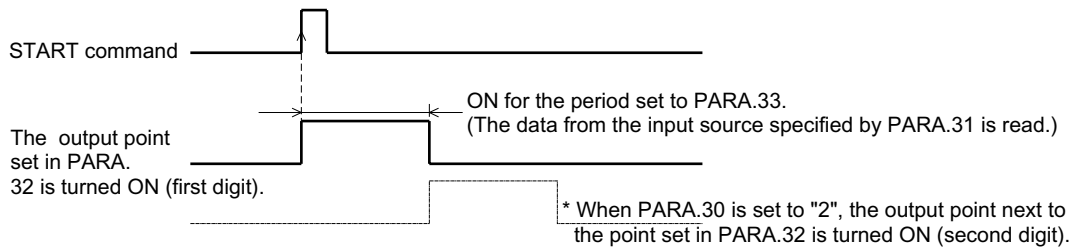

- Specifying the program No. from a general programmable controller. When specifying the program No. from any programmable controller other than an FX/FX2C Series unit, perform the following procedure. (When an FX/FX2C Series unit is connected, the program No. can be specified via communication with the buffer memory.)

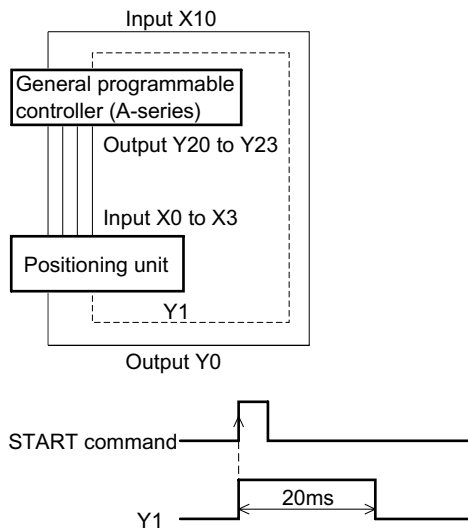

Example: When the programmable controller is an A Series unit.

Example of parameter settings in the positioning unit.

PARA. 30	Setting: 1
PARA. 31	X0 (X0 to X3)
PARA. 32	Y0
PARA. 33	20msec

A Series program

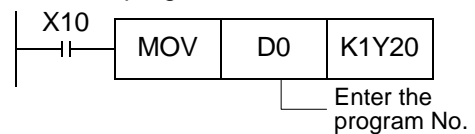

RDY output

**PARA. 34: Ready (RDY) output valid**

Set whether or not to output the ready (preparation completion) signal of the positioning unit.

Setting for the FX(E)-20GM	Setting for the FX-10GM
Setting = "0" : Invalid	
Setting = "1" : Valid (PARA.35 must be set.)	

**PARA. 35: RDY output No.**

Set the output point No. from which the RDY signal is output when PARA. 34 is set to "1". (One point is occupied.)

Setting for the FX(E)-20GM	Setting for the FX-10GM
Y0 to Y67	Y0 to Y5

#### 4.4.2 Outputting the M code to the outside

This section explains the parameters related to external output of the M code and the manual pulse generator.

##### M code external output

Output the M code to the outside using the general output of the positioning unit.

##### **PARA. 36: M code external output valid**

Set whether or not to output the M code to the outside.

Setting for the FX(E)-20GM	Setting for the FX-10GM
Setting = "0" : Invalid	Setting = "1" : Valid

Even when PARA. 36 is set to "0 (invalid)", the special relays and the special data registers (such as the M code, the M code ON signal, the M code OFF signal, etc.) related to the M code are still valid. When PARA. 36 is set to "1", PARA. 37 and PARA. 38 must be set.

##### **PARA. 37: M code external output No.**

Specify the head No. of the destination in the positioning unit to which the M code is output.

Setting for the FX(E)-20GM	Setting for the FX-10GM
Y0 to Y57 Head No. of destination M code ON output (one point).	Y0 Head No. of destination M code ON output (one point).
Consecutive 8 points :M code (2-digit BCD) Nine points in all are occupied.	Consecutive 5 points :M code (1-digit BCD) Six points in all are occupied.

Setting example: When "Y0" is specified as the head of destination

FX(E)-20GM

Y0 : M code ON output (one point)

Y1 to Y10 : M code (eight points \*1)

FX10GM

Y0 : M code ON output (one point)

Y1 to Y5 : M code (five points)

\*1 When the output of the M code can be performed in one digit, the number of outputs point can be saved by adjusting the setting so that the 4 upper bits move beyond the output area.

##### **PARA. 38: M code OFF command input No.**

Specify the input No. of the positioning unit to which the M code OFF command is entered.

Setting for the FX(E)-20GM	Setting for the FX-10GM
X0 to X67, X372 to X377	X0 to X3, X375 to X377





### 4.4.3 Manual pulse generator

Set the parameters required to use the manual pulse generator.

Up to two manual pulse generators can be connected to the FX(E)-20GM. Only one manual pulse generator can be connected to the FX-10GM.

Manual pulse generator

#### **PARA. 39: Manual pulse generator**

Set whether or not to use manual pulse generators.

Setting for the FX(E)-20GM	Setting for the FX-10GM
Setting = "0" : Invalid	Setting = "0" : Invalid.
Setting = "1" : Valid (one pulse generator).	Setting = "1" : Valid (one pulse generator).
Setting = "2" : Valid (two pulse generators).	

When the X axis is set to "2" in the 20GM, the setting of the Y axis is ignored. When PARA. 39 is set to "1" or "2", the following parameters must be set.

#### **PARA. 40: Multiplying factor per pulse generated by manual pulse generator**

The input pulses are multiplied by a value set here, then output.

Setting for the FX(E)-20GM	Setting for the FX-10GM
1 to 255	

Refer to PARA. 41.

#### **PARA. 41: Division rate for multiplied result**

The input pulses multiplied by the value set to PARA. 40 are divided by the value set here.

Setting for the FX(E)-20GM	Setting for the FX-10GM
2 <sup>n</sup> n=0 to 7	Not available

Multiplying factor and division rate

The number of input pulses is multiplied by the multiplying factor and divided by the division rate as follows.

$$\frac{(\text{Number of input pulses entered from manual pulse generator}) \times \text{PARA. 40 (multiplying factor: 1 to 255)}}{\text{PARA. 41 (division rate: 2}^n\text{) ... (not available in the FX-10GM)}} = \text{Number of output pulses.}$$

#### **PARA. 42: Head input No. for manual pulse generator enable (pulse input permission)**

When the input No. set here is ON, the positioning unit receives the input from the manual pulse generator.

Setting for the FX(E)-20GM	Setting for the FX-10GM
X0 to X67 (Two points are occupied.)	X0 to X3 (One point is occupied.)

The inputs of the manual pulse generator are assigned as shown in the table below.

Set value	FX(E)-20GM		FX-10GM
	PARA.39 [1]	PARA.39 [2]	PARA.39 [1]
X00	Phase A	X axis, phase A	Phase A
X01	Phase B	X axis, phase B	Phase B
X02		Y axis, phase A	
X03		Y axis, phase B	
Set to PARA.42	Enable	X axis enable	Enable
	*1 Switching between the X and Y axes.	Y axis enable	

Pay attention to the cod 31/71/72 instruction which use the same inputs.

These input Nos. are fixed.

\*1 When only one manual pulse generator is connected, it can be used for the X axis while the specified input is OFF or for the Y axis while the specified input is ON.

#### 4.4.4 Detecting the absolute position (ABS)

The present value can be automatically read from a servo motor with absolute position detection by setting the following parameters.

Parameters related to ABS

##### PARA. 50: ABS interface

Set whether or not to detect the absolute position.

Setting for the FX(E)-20GM	Setting for the FX-10GM
Setting = "0" : Invalid.	
Setting = "1" : Valid.	

Set the following parameters when PARA. 50 is set to "1".

##### PARA. 51: Head input No. for ABS

Set the head input No. of the input destination for the absolute position data.

Setting for the FX(E)-20GM	Setting for the FX-10GM
X0 to X66	X0 to X2, X375 to X376
Specified No(head) :ABS data bit 1. (Next No.):Send data ready. ) Two points are occupied.	

##### PARA. 52: Head output No. for ABS control

Set the head output No. of the destination for the absolute position data control.

Setting for the FX(E)-20GM	Setting for the FX-10GM
Y0 to Y65	Y0 to Y3
Specified device No(head) :ABS transfer mode. (Next No.):ABS request and servo ON. ) Three points are occupied.	

Absolute position detection operation

- When the power of the positioning unit is turned ON, it drives the servo ON output and the ABS transfer mode output.
- In response to these outputs, 38(32+6)-bit data is communicated while receiving and sending are confirmed using the send data ready signal and the ABS request signal.
- The data is transmitted via the 2-bit line (ABS bit 0 and ABS bit 1).
- When detecting the absolute position, set PARA. 16 (machine zero point address) to "0".

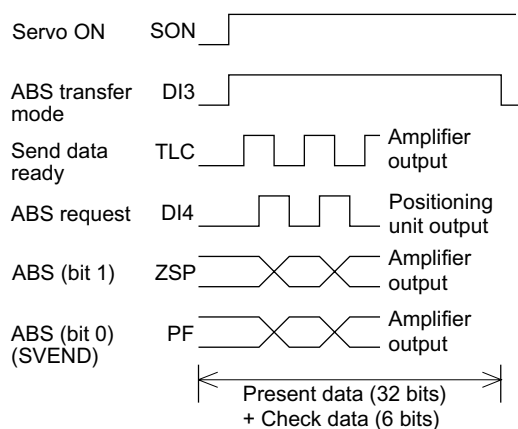

### 4.4.5 Single-step operation and general purpose input

This section explains the parameters related to the single-step operation and general purpose input.

Single-step operation

**PARA. 53: Single-step operation**

Set whether or not to perform the single-step operation.

Setting for the FX(E)-20GM	Setting for the FX-10GM
Setting = "0" : Invalid.	
Setting = "1" : Valid.	

PARA. 54 must be set when PARA. 53 is set to "1 (valid)".

**PARA. 54: Single-step mode input No.**

The single-step mode is valid while the input set here is ON.

Setting for the FX(E)-20GM	Setting for the FX-10GM
X0 to X67, X372 to X377	X0 to X3, X375 to X377
One point is occupied.	

Single-step operation

The single-step mode is valid while PARA. 53 is set to "1" and the input No. set to PARA. 54 is ON. When the START signal is turned ON in the single-step mode, the specified program is executed one line at a time.

The single-step mode can be made available by turning ON the M9000 (for the X axis), M9001 (for the Y axis) or M9002 (for subtask) instead of using PARA. 53 and PARA. 54. If special auxiliary relays are used the setting of PARA. 53 and PARA. 54 is not necessary.

General purpose input

**PARA. 56: General purpose input declaration for FWD/RVS/ZRN**

The dedicated inputs FWD (forward rotation JOG), RVS (reverse rotation JOG) or ZRN (zero return) can be used as general purpose inputs.

When X372 to X377 (X375 to X377 in the 10GM) are used for general purpose inputs in the parameters or the programs, this parameter must be set properly.

Setting	Setting for the FX(E)-20GM		Setting for the FX-10GM	
	Use X372 to X377 as general purpose input	FWD/RVS/ZRN signal valid	Special M signal valid	
0	Never	Always	Always	
1	In Auto mode	Manu mode only (not Auto mode).	Manu mode only (not Auto mode).	
2	Always	Never	Never	
3	In Auto mode	Manu mode only (not Auto mode).	Always	
4	Always	Never	Always	

Note: The table below shows the details of the special auxiliary relays. Those for the X axis only are available in the FX-10GM.

Details of command	X axis	Y axis
Machine zero return command	M9004	M9020
FWD JOG command	M9005	M9021
RVS JOG command	M9006	M9022

Note: The table below shows the input No. when the dedicated inputs are used as general purpose inputs. Those for the X axis only are available in the FX-10GM.

External input	X axis	Y axis
ZRN	X375	X372
FWD	X376	X373
RVS	X377	X374

Reference Initial values: Section 4.4.6

#### 4.4.6 Default values (initial values)

The table below shows the default values of the I/O control parameters set in the factory.

**Table:4.2 Default values (initial values)**

PARA. No.	Description	Initial value		Remarks
		20GM	10GM	
30	Program No. specification method.	0	0	Program No. is fixed to "0".
31	Head input No. for DSW time-sharing reading.	0	0	Input :X0
32	Head output No. for DSW time-sharing reading.	0	0	Output :Y0
33	DSW reading interval.	20	20	20ms
34	RDY output valid.	0	0	Invalid
35	RDY output No.	0	0	Output :Y0
36	M code external output valid.	0	0	Invalid
37	M code external output No.	0	0	Input :Y0 to Y10
38	M code OFF command input No.	0	0	Output :X0
39	Manual pulse generator.	0	0	Invalid
40	Multiplying factor per pulse generated by manual pulse generator.	1	1	× 1
41	Division rate for multiplied result.	0		
42	Head input No. for manual pulse generator enable.	2		Input :X2
43 to 49	Vacant.			
50	ABS interface.	0	0	Invalid
51	Head input No. for ABS.	0	0	Input :X0 to X1
52	Head output No. for ABS control.	0	0	Output :Y0 to Y1
53	Single-step operation.	0	0	Invalid
54	Single-step mode input No.	0	0	Input :X0
55	Vacant.			
56	General purpose input declaration for FWD/RVS/ZRN.	0	0	Not used as general purpose inputs.

## 4.5 Special Devices

This section explains the special auxiliary relays and the special data registers of the positioning unit.

### 4.5.1 General description

The auxiliary relays from M9000 and the data registers from D9000 onwards are assigned as special devices. Various command inputs, status information and parameter set values can be read and written in accordance with control.

#### Special auxiliary relays

The special auxiliary relays (special Ms) are mainly used for command inputs by writing and as status information by reading.

[ Command inputs ] writing (reading)

Operation commands can be given by turning ON the special Ms such as start/stop and FWD/RVS/ZRN, and can be controlled by programs without using external input terminals.

Some special Ms are turned ON when a command is entered from an external input terminal, so can also be used for reading.

[ Status information ] reading

These special Ms are read and used to indicate the status of the positioning unit.

#### Special data registers

The information of the present position and the program No./step No. being executed and various parameter settings are saved in special data registers, and can be read and written by programs.

Note: The special Ms and the special Ds are also assigned to the buffer memories (BFM), and those in the FX-10GM or the FX-20GM can be read and written from a programmable controller using the programmable controller program (FROM/TO instruction). (Refer to Section 7.2.)

How to use the special Ms/Ds

- The special Ms and the special Ds are used (in the positioning program) as follows.

### How to use the special Ms/Ds for reading

In the case of special Ms

```

NO   O100          Subtask program
    }
N50  LDM  9050     X axis error detection
N51  OUT  Y0       Y0 output
    }
    m102          END
  
```

Special Ms are treated as contacts when reading. In the example shown on the left, a general purpose output Y0 is used to give an output to the outside when an error occurs in the X axis. (For subtasks, refer to Section 5.8.)

In the case of special Ds

```

NO   O100          Subtask program
    }
N40  FNC74(SEGL)  7-segment time-sharing display
      D9005       X axis present position
      Y0
      K3
      K0
    }
    m102          END
  
```

The present value (3 digits) of the X axis is displayed on the outside using the FNC 74 (SEGL) instruction. (For the FNC 74, refer to Section 6.7.)

### How to use the special Ms/Ds for writing

In the case of special Ms

```

NO   O100          Subtask program
    }
N50  LD   X0       General purpose input X0
      OUT M9007    X axis error reset
    }
    m102          END
  
```

Special Ms are treated as coils when writing. In the example shown on the left, the X axis error is reset (M9007) using the general purpose input X0.

In the case of special Ds

```

NO   O100          Subtask program
    }
      FNC12 (D MOV) Transfer instruction (32 bits)
      K20,000
      D9208       PARA. 4: Maximum speed
    }
  
```

Change the setting of PARA. 4 (maximum speed for the X axis) to "20,000". In this case the special D needs to be a double word, also a 32-bit instruction must be used.

	Subtask program	:Section 5.8
Reference	Application instruction FNC 74	:Refer to Section 6.7
	Application instruction FNC 12	:Refer to Section 6.5

## 4.5.2 Special auxiliary relays

Special auxiliary relays (specification inputs) for writing.

Y axis not available in FX-10GM.

**Table:4.3 Special auxiliary relays**

Special auxiliary relay			Attribute	Description	
X axis	Y axis	General/subtask			
M9000	M9016	M9112	Writing (Reading)	Single-step mode command.	When these special Ms are driven by a main task program (simultaneous 2-axis program or X/Y axis program) or subtask program, they function as substitute commands for input terminal commands of the positioning unit.
M9001	M9017	M9113		Start command.	
M9002	M9018	M9114		Stop command.	
M9003	M9019			M code OFF command.	
M9004	M9020			Machine zero return command.	
M9005	M9021			FWD JOG command.	
M9006	M9022			RVS JOG command.	
M9007	M9023	M9115		Error reset.	
M9008	M9024			Zero return axis control.	
M9009	M9025			Not defined.	
M9010	M9026		Not defined.		
M9011	M9027	M9116		Not defined.	
M9012	to	to		However, M9118 functions as shown on the next page.	
M9013	M9030	M9125			
M9014			Writing	16-bit FROM/TO mode (general purpose/file register).	Not defined 10GM.
M9015				Continuous path mode.	
	M9031	M9126		Not defined.	
		M9127	Writing (Reading)	Battery LED. Lighting control.	Not defined 10GM.
		M9132		Not defined.	
		M9133			
		M9134			
		M9135			
M9036	M9041				
M9037	M9042				
M9038	M9043				
M9039	M9044				
M9040	M9045				
M9046, M9047				Not defined.	

- In the simultaneous 2-axis mode (available only in the 20GM), even if the single-step mode command, the start command, the stop command or the M code OFF command is given only to the X or Y axis, it is valid for the both axes.
- The ON/OFF status of the special auxiliary relays for command inputs are continuously monitored by the CPU inside the positioning unit.
- When the power is turned ON, each special auxiliary relay is initialized to OFF.

\*1 A relay whose attribute is marked "(Reading)" in the table above is turned ON when a command input is given via an external input terminal.

Special auxiliary relays (status information) for reading.

Y axis not available in FX-10GM.

Special auxiliary relay			Attribute	Description	
X axis	Y axis	General/subtask			
M9048	M9080	M9128	Reading	READY/BUSY	These special Ms are turned ON/OFF in accordance with the status of the positioning unit.
M9049	M9081			Positioning completed.	
M9050	M9082	M9129		Error detection.	
M9051	M9083			M code ON signal. *1	
M9052	M9084			M code standby status. *1	
M9053	M9085	M9130		m00 (m100) standby status.	
M9054	M9086	M9131		m02 (m102) standby status.	
M9055	M9087			Stop remaining drive standby status.	
M9056	M9088	M9132		Automatic operation in progress (subtask operation progress). *1	
M9057	M9089			Zero return completed.	
M9058	M9090			Not defined.	
M9059	M9091			Not defined.	
M9060	M9092	M9118		Operation error. *1	
M9061	M9093	M9133		Zero flag. *1	
M9062	M9094	M9134		Borrow flag. *1	
M9063	M9095	M9135		Carry flag. *1	
M9064	M9096		Reading	DOG input.	These special Ms are turned ON/OFF in accordance with the ON/OFF status of the positioning unit.
M9065	M9097			START input.	
M9066	M9098			STOP input.	
M9067	M9099			ZRN input.	
M9068	M9100			FWD input.	
M9069	M9101			RVS input.	
M9070	M9102			Not defined.	
M9071	M9103			Not defined.	
M9072	M9104			SVRDY input.	
M9073	M9105			SVEND input.	
M9074	M9106		Not defined.		
M9075 to M9079	M9107 to M9111	M9136 to M9138		Not defined.	
		M9139	Reading	Independent 2-axis/simultaneous 2-axis. *2	These special Ms are turned ON/OFF in accordance with the program being executed, the terminal input status, in the positioning unit.
		M9140		Terminal input : MANJ	
		M9141		Terminal input : EM STOP *2	
		M9142		Not defined.	
		M9143		Low battery voltage. *2	
M9144	M9145		Reading (Writing)	Present value establish flag (This is set when zero return or absolute position detection is performed once and reset when the power is turned OFF).	
M9146 to M9175				Not defined.	

\*1 In the simultaneous 2-axis mode, both the X and Y axes operate simultaneously.

\*2 Not defined in the FX-10GM.



### 4.5.3 Special data registers

Special data registers

Y axis not available in FX-10GM.

**Table:4.4 Special data registers**

X axis		Y axis		General/subtask		Attribute	Description
Upper	Lower	Upper	Upper	Upper	Upper		
	D9000		D9010			R/W	Program No. specification (PARA.30:~3~). *1
	D9001		D9011			R	Program No. being executed. *2 S
	D9002		D9012		D9100	R	Line No. being executed. *2 S
	D9003		D9013			R	M code (binary). *2 S
D9005	D9004	D9015	D9014			R/W	Present position (Refer to the bottom on the next page) S
D9007	D9006	D9017	D9016				Not defined. D
D9009	D9008	D9019	D9018				Not defined.
					D9020	R	Memory capacity.
					D9021	R	Memory type. S
					D9022	R	Battery voltage. *3 S
					D9023	(R/W)	Low battery voltage detection level (Initial value: *3) S
					D9024	R	Number of momentary power interruptions detected. *3 S
					D9025	(R/W)	Momentary power interruption detection time. (Initial value: 10 msec) *3 S
					D9026	R	Model No.: 5210 (20GM) or 5310 (10GM) S
					D9027	R	Version. S
					D9028		Not defined. S
					D9029		Not defined.
D9030 to D9039		D9040 to D9049		D9050 to D9059			Not defined.
	D9060		D9080		D9101	R	Step No. being executed. *2
	D9061		D9081	(D9103)	D9102	R	Error code. *2 S
	D9062		D9082			R	Instruction group A: cod present status. *2 S
	D9063		D9083			R	Instruction group D: cod present status. *2 S
D9065	D9064	D9085	D9084	D9105	D9104	R	Dwell time set value. *2 S
D9067	D9066	D9087	D9086	D9107	D9106	R	Dwell time present value. *2 D
(D9069)	D9068	(D9089)	D9088	(D9109)	D9108	R	Number of repeats set value. *2 D
(D9071)	D9070	(D9091)	D9090	(D9111)	D9110	R	Number of repeats present value. *2 S
D9073	D9072	D9093	D9092			R	Not defined. S
D9075	D9074	D9095	D9094			R	Present position (converted into pulses).
(D9077)	D9076	(D9097)	D9096	(D9113)	D9112	R	Step No. in which operation error has occurred. *2 D
D9079	D9078	D9099	D9098	D9114 to D9119			Not defined. S
D9121	D9120	D9123	D9122			R/W	X/Y axis compensation data.
D9125	D9124					R/W	Arc center point (i) compensation data. *3 D
		D9127	D9126			R/W	Arc center point (j) compensation data. *3 D
Upper bits D9129 to Lower bits D9128						R/W	Arc radius (r) compensation data. *3 D
				D9130 to D9139			Not defined. D
D9140 to D9199						See next page.	

\*1 In simultaneous 2-axis mode (available only in the 20GM), the special D for the X axis is valid and the special D for the Y axis is ignored.

\*2 In simultaneous 2-axis mode (available only in the 20GM), the same data is saved in the special D for the X axis and the special D for the Y axis.

\*3 Not defined in the FX-10GM.

X axis		Y axis		General/subtask		Attribute	Description
Upper	Lower	Upper	Lower	Upper	Lower		
					D9140	R/W	Index register. V0 <b>S</b>
					D9141		" V1 <b>S</b>
					D9142		" V2 <b>S</b>
					D9143		" V3 <b>S</b>
					D9144		" V4 <b>S</b>
					D9145		" V5 <b>S</b>
					D9146		" V6 <b>S</b>
					D9147		" V7 <b>S</b>
				D9149	D9148	R/W	Index register. Z0 <b>D</b>
				D9151	D9150		" Z1 <b>D</b>
				D9153	D9152		" Z2 <b>D</b>
				D9155	D9154		" Z3 <b>D</b>
				D9157	D9156		" Z4 <b>D</b>
				D9159	D9158		" Z5 <b>D</b>
				D9161	D9160		" Z6 <b>D</b>
				D9163	D9162	" Z7 <b>D</b>	
D9164 to D9199						Not defined.	

Attribute R : This data register is for reading only. Do not attempt to write any data to it.

R/W : This data register can be read and written. However, do not attempt to write any data to the registers whose attribute is (R/W).

When using the FROM/TO instruction, use a 16-bit instruction for **S** and 32-bit instruction for **D**. (For connection with a programmable controller, refer to Section 7.)

Special Ds for present position (shown on the previous page)

The present position data based on the units specified by PARA. 3 is saved in the data registers (D9005, D9004) and (D9015, D9014).

Numeric data can be written to these data registers when the FX(E)-20GM is in the READY status (in either AUTO or MANU mode) and not in the remaining distance drive standby status.

Use the **D** TO **P** instruction to write data from the programmable controller.

The data registers (D9075, D9074) and (D9095, D9094) which indicate the present position converted into pulses are for reading only, and their contents automatically change interlocking with the changes in the contents of the data registers mentioned in .

Special data registers for parameters.  
Positioning parameters

Y axis not available in FX-10GM.

**Table:4.5 Special data registers**

X axis		Y axis		Attribute	Description
Upper	Lower	Upper	Lower		
D9201	D9200	D9401	D9400	R/W	PARA.0: System of units. <b>D</b>
D9203	D9202	D9403	D9402		PARA.1: Number of command pulses per rotation of motor. <b>D</b>
D9205	D9204	D9405	D9404		PARA.2: Travel per rotation of motor. <b>D</b>
D9207	D9206	D9407	D9406		PARA.3: Minimum command unit. <b>D</b>
D9209	D9208	D9409	D9408		PARA.4: Maximum speed. <b>D</b>
D9211	D9210	D9411	D9410		PARA.5: JOG speed. <b>D</b>
D9213	D9212	D9413	D9412		PARA.6: Bias speed. <b>D</b>
D9215	D9214	D9415	D9414		PARA.7: Backlash compensation. <b>D</b>
D9217	D9216	D9417	D9416		PARA.8: Acceleration time. <b>D</b>
D9219	D9218	D9419	D9418		PARA.9: Deceleration time. <b>D</b>
D9221	D9220	(D9421	D9420)		PARA.10: Interpolation time constant. <b>*1 D</b>
D9223	D9222	D9423	D9422		PARA.11: Pulse output format. <b>D</b>
D9225	D9224	D9425	D9424		PARA.12: Rotation direction. <b>D</b>
D9227	D9226	D9427	D9426		PARA.13: Zero return speed. <b>D</b>
D9229	D9228	D9429	D9428		PARA.14: Creep speed. <b>D</b>
D9231	D9230	D9431	D9430		PARA.15: Zero return direction. <b>D</b>
D9233	D9232	D9433	D9432		PARA.16: Machine zero point address. <b>D</b>
D9235	D9234	D9435	D9434		PARA.17: Zero point signal count. <b>D</b>
D9237	D9236	D9437	D9436		PARA.18: Zero point signal count start timing. <b>D</b>
D9239	D9238	D9439	D9438		PARA.19: DOG switch input logic. <b>D</b>
D9241	D9240	D9441	D9440		PARA.20: Limit switch logic. <b>D</b>
D9243	D9242	D9443	D9442		PARA.21: Positioning completion error evaluation time. <b>D</b>
D9245	D9244	D9445	D9444		PARA.22: Servo ready check. <b>D</b>
D9247	D9246	D9447	D9446		PARA.23: Stop mode. <b>D</b>
D9249	D9248	D9449	D9448		PARA.24: Electrical zero point address. <b>D</b>
D9251	D9250	D9451	D9450		PARA.25: Software limit (upper). <b>D</b>
D9253	D9252	D9453	D9452	PARA.26: Software limit (lower). <b>D</b>	

\*1 Although the special Ds for the Y axis (D9421, D9420) are assigned, only the special Ds for the X axis (D9221, D9220) are valid. Those for the Y axis are ignored.

Special data relay for parameters.  
I/O control parameters

Y axis not available in FX-10GM.

X axis		Y axis		Attribute	Description
Upper	Lower	Upper	Lower		
D9261	D9260	D9461	D9460		PARA.3 Program No. specification method. *2 <b>D</b>
D9263	D9262	D9463	D9462		PARA.3 Head input No. for DSW time-sharing reading. *2 <b>D</b>
D9265	D9264	D9465	D9464		PARA.3 Head output No. for DSW time-sharing reading. *2 <b>D</b>
D9267	D9266	D9467	D9466		PARA.3 DSW reading interval. *2 <b>D</b>
D9069	D9268	D9469	D9468		PARA.3 RDY output valid. *2 <b>D</b>
D9271	D9270	D9471	D9470		PARA.3 RDY output No. *2 <b>D</b>
D9273	D9272	D9473	D9472		PARA.3 M code external output valid. *2 <b>D</b>
D9275	D9274	D9475	D9474		PARA.3 M code external output No. *2 <b>D</b>
D9277	D9276	D9477	D9476		PARA.3 M code OFF command input No. *2 <b>D</b>
D9279	D9278	D9479	D9478		PARA.3 Manual pulse generator. *2 <b>D</b>
D9281	D9280	D9481	D9480		PARA.4 Multiplying factor per pulse generated by manual pulse generator. *2 <b>D</b>
D9283	D9282	D9483	D9482		PARA.4 Division rate for multiplied result. *2 <b>D</b>
D9285	D9284	D9485	D9484		PARA.4 Head input No. for manual pulse generator enable. *2 <b>D</b>
D9287	D9286	D9487	D9486	R/W	PARA.4
D9289	D9288	D9489	D9488		PARA.4
D9291	D9290	D9491	D9490		PARA.4
D9293	D9292	D9493	D9492		PARA.4 Vacant.
D9295	D9294	D9495	D9494		PARA.4
D9297	D9296	D9497	D9496		PARA.4
D9299	D9298	D9499	D9498		PARA.4
D9301	D9300	D9501	D9500		PARA.5 ABS interface. <b>D</b>
D9303	D9302	D9503	D9502		PARA.5 Head input No. for ABS. <b>D</b>
D9305	D9304	D9505	D9504		PARA.5 Head output No. for ABS control. <b>D</b>
D9307	D9306	D9507	D9506		PARA.5 Single-step operation. <b>D</b>
D9309	D9308	D9509	D9508		PARA.5 Single-step mode input No. <b>D</b>
D9311	D9310	D9511	D9510		PARA.5 Vacant.
D9313	D9312	D9513	D9512		PARA.5 General-purpose input declaration for FWD/RVS/ZRN. <b>D</b>

\*2 In simultaneous 2-axis mode, the value set for the X axis is valid and the value set for the Y axis is ignored.

- When data is written to the programmable controller (using the FROM/TO instruction), use a 32-bit instruction for **D**.
- A data register whose attribute is R/W can be read and written by the user.

# 5. POSITIONING CONTROL INSTRUCTIONS

This section explains the cod instructions for positioning control and the M code instructions for driving auxiliary equipment.

## 5.1 General Rules for Positioning Control Instructions

This section explains the general contents common to the positioning control instructions.

### 5.1.1 Program format

The positioning program is expressed as follows.

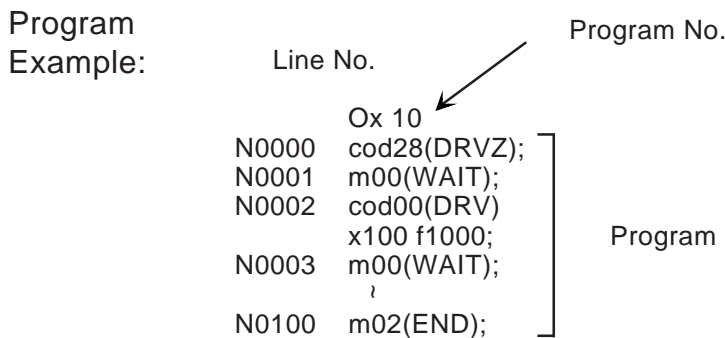

Line No.

- The line No. (N0 to N9999) is assigned to each instruction so that separation of instruction words can be easily distinguished. The head line No. is entered from a peripheral unit. After that, the next No. is automatically assigned to the next instruction every time the delimiter (;) is entered. Instruction words can be read using the line No..
- Any numeric of 4 digits or less can be selected as the head line No. The same No. can be assigned to different programs which have a different program No. (refer to the next page.). The head line No. does not have to be "N0000".
- The capacity of the program is controlled by the number of steps. The number of steps used in one line varies depending on the instruction word. The line No. is not included in the number of steps.

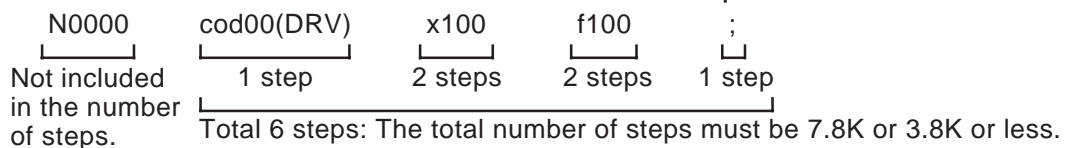

Program No.

- The program No. is assigned to each positioning program. A different No. is assigned to a program for different operation.
- "O" is attached to the program No. The program No. format is classified into that for simultaneous 2-axis operation (in the FX(E)-20GM), that for independent 2-axis operation (1-axis operation in the FX-10GM) and that for subtasks.
- The END instruction ("m02" for simultaneous 2-axis operation, X axis operation or Y axis operation and "m102" for subtasks) must be provided at the end of each program.

Simultaneous 2-axis operation	Independent 2-axis operation		Subtasks
	X axis	Y axis	
O00; 	Ox00; 	Oy00; 	O100; 
m02(END)	m02(END);	m02(END);	m102(END);

Only program No. for the X axis and subtasks are available in the FX-10GM.

- Program No.00 to 99 (100 in total) are available as follows. ("O100" only is available for subtasks.)

O00 to O99	Ox00 to Ox99	Oy00 to Oy99	O100
------------	--------------	--------------	------

- In the FX(E)-20GM, programs for simultaneous 2-axis operation and programs for independent 2-axis operation cannot be mixed together. Only one type or the other is allowed.  
If both types of program are present, a program error (error code: 3010) occurs.
- The program No. to be executed can be specified from a digital switch or programmable controller depending on the setting of PARA. 30 (program No. specification method). (Refer to Section 5.1.4.)

Program

- When the START input is entered, the positioning program whose program No. is specified is executed step by step from the top.

Specified program No.	Execution in the order programmed.
Ox20	When execution of one instruction is finished, the instruction in the next line is executed. For example, in the case of "N0001" shown on the left, when the X axis travel reaches "1000", execution proceeds to the next line. In the line N0100, when the timer reaches timeout, execution proceeds to the next line.
N0000 cod28(DRVZ);	
N0001 cod00(DRV) x1000 f2000;	
N0100 cod04(TMR) K100; m02(END);	

Incremental/Absolute drive

In all the FX-10GM, the FX-20GM and the E-20GM, the absolute drive method is adopted by default to specify a position.

To use the incremental drive method, use the cod 91 (INC) instruction described later. Refer to Section 5.7.

### 5.1.2 Instruction format

In this manual, the format of a positioning control instruction is detailed as follows.

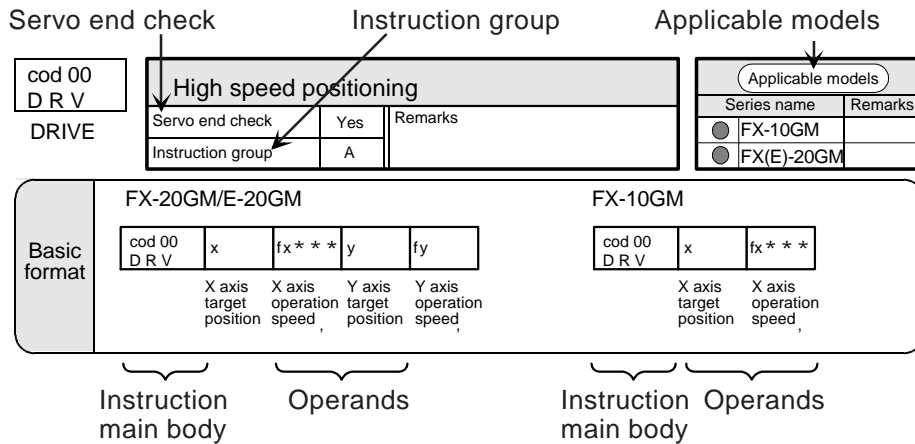

#### Applicable models

The models in which the instruction described can be used are indicated. The models are classified into "FX-10GM" and "FX(E)-20GM". The applicable group is marked with " ● ".

#### Instruction main body

The positioning control instruction consists of the instruction main body and the operands (shown in the table below). (Some instructions do not include any operand.)

The instruction main body consists of the instruction word (such as DRV, LIN, CW, etc.) and the code No. (cod No.).

An instruction can be written to or read from a peripheral unit by specifying either the word or the code No.

#### Operands

Various types of operands such as the travel, the speed, etc. are available for various types of instruction. Select the required operands in the specified sequence. The table below shows the available operands.

Types of operands

**Table:5.1 Instruction format**

Type of operands	20GM	10GM	Units	Indirect specification	Omission of operand
x :X axis coordinates (travel), incremental/absolute.			Set by parameter	Possible using data register (D)	The axis whose operand is omitted maintains its present status and does not move.
y :Y axis coordinates (travel), incremental/absolute.		-			
i :X axis coordinates (arc center), incremental.		-			This operand cannot be omitted.
i :Y axis coordinates (arc center), incremental.		-			
r :Arc radius.		-			
f :Vector speed or peripheral speed.					The "f" value of the previous usage becomes valid.
k :Timer constant.			10ms	This operand cannot be omitted.	
m :M code in WITH mode.			-	Unable	This operand can be omitted (No M code is output).

Units of operands

The units of the value specified by the operands are determined by the parameters.

- Travel (x, y, i, j, r)  
The motor system (PLS) or the mechanical system (mm, inch, deg) is valid in accordance with the setting of PARA. 0 (system of units).  
The scaling of the set value is performed in accordance with the setting of PARA. 3 (minimum command unit).
- Speed (f)  
The set value must be equal to or less than the setting of PARA. 4 (maximum speed).  
FX-20GM : 200 kPPS or less.  
(100 kPPS or less for linear/circular interpolation.)  
FX-10GM : 200 kPPS or less.

Indirect specification

Indirect specification indicates the method to write indirectly the set values by specifying data registers (including file registers and index registers) instead of writing directly the set values to the operands.

- Direct specification  

cod00	x1000	f2000;	
	↑	↑	) The set values are directly written.
	└ Travel = 1000	└ Speed = 2000	
- Indirect specification  

cod00	xD10	fD20;	
	↑	↑	) The set values are determined in accordance with the contents of the data registers.
	└ Travel = D10	└ Speed = D20	

When the set value exceeds 16 bits, specify "xDD10" for example. By this specification, 32-bit data (D11, D10) can be handled.

The data register No. used for indirect specification can be modified with index registers V and Z. The data can be selected by modification.

Example: When (V2) = 10, "D20V2" indicates "D30". When the contents of D30 is "500", "xD20V2" becomes equivalent to "xD30" (that is, "x500").

Sixteen index registers in all, V0 to V7 and Z0 to Z7, are available.

- V0 to V7: 16-bit registers
- Z0 to Z7: 32-bit registers



Omission of operands

In the instructions (CW, CCW and TIM) in which r (arc radius) or K (timer constant) must be specified, the operands cannot be omitted.

When fx (X axis operation speed) or fy (Y axis operation speed) are omitted in the cod 00 (DRV) instruction, the corresponding axis will operate at the maximum speed specified by PARA. 4 (maximum speed).

**Instruction groups**

- In this manual, instructions are classified into four groups (A to D).

**Group A**

When the same instruction (same code No.) is used consecutively the code No. can be omitted and only the necessary operands are required.

Example: N100 cod00(DRV) x100;  
N101 x200;

Executed by the cod 00 instruction.

Instruction names

cod00(DRV), cod01(LIN)  
cod02(CW), cod03(CCW)  
cod31(INT)

**Group B**

The code No. cannot be omitted. An instruction in this group is valid only in the line No. in which the instruction is specified.

Example: N200 cod73(MOVC) X10;  
          ?                                  ?  
N300 cod73(MOVC) X20;  
          ?                                  ?

Instruction names

cod04(TMR), cod09(CHK)  
cod28(DRVZ), cod29(SETR)  
cod30(DRBR), cod71(SINT)  
cod72(DINT), cod92(SET)

**Group C**

An instruction in this group remains valid once executed until the contents are changed by the same instruction.

Example: N200 cod73(MOVC) X10;  
          ?                                  ?  
N300 cod73(MOVC) X20;  
          ?                                  ?

The X axis travel is compensated by "+10".  
The travel is compensated by "+10" in this area.  
The X axis travel is compensated by "+20".

cod73(MOVC), cod74(CNTC)  
cod75(RADC), cod76(CANC)

**Group D**

An instruction in this group remains valid once executed until another instruction in this group is executed.

Example: N300 cod91(INC);  
          ?                                  ?  
N400 cod92(ABS);  
          ?                                  ?

The travel is indicated by the incremental drive method.  
Incremental addresses are indicated in this area.  
The travel is indicated by the absolute drive method.

cod90(ABS), cod91(INC)

**Servo end check**

When an instruction for which the servo end check is "Yes" is executed, the servo end check is automatically performed after driving is completed. The system makes sure that the deviation pulses inside the servo amplifier are less than the quantity specified (set by servo amplifier parameters), then proceeds to the next operation.

If the servo end signal is not transmitted from the servo amplifier to the positioning unit within the time set to PARA. 21 (positioning completion signal error evaluation time), an external error (Error code: 4002 = servo end error) occurs and the machine stops operation. When PARA. 21 is set to "0", the servo end check is not performed even if the servo end check is "Yes" for the instruction executed.

The cod 09 (CHK) instruction described later can be used to perform the servo end check.

### 5.1.3 M code instruction format

M code instructions are used to drive various auxiliary equipment (such as chucks, drills, etc.) in association with positioning operations.

M code: M00 to M99 (100 points)

M code instructions are expressed as "m" to be distinguished from "M" which stands for an auxiliary relay.

Note: Each of the X and Y axes has 100 M code instructions.

#### M code driving methods

In the AFTER mode, only M code instructions are executed. In the WITH mode, M code instructions and other instructions are simultaneously executed.

**AFTER mode**  
 N0 cod01(LIN) X400 Y300 f200;  
 N1 m10; The M code is programed on a separate line.  
 N2 m11; Other auxiliary equipment is driven immediately afterwards.

**WITH mode**  
 cod01(LIN) X400 Y300 f200 m10;  
 When an M code is added as the final operand in any type of positioning control instruction, the WITH mode is established as shown below. The program execution proceeds to the next line after execution of the instruction is completed and the M code OFF signal is turned ON.

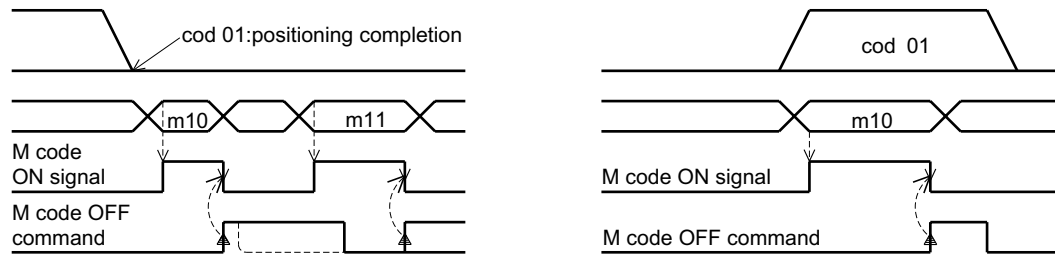

In either case above, when an M code is driven, the M code ON signal is turned ON and the M code No. is saved in special Ds. The M code ON signal remains ON until the M code OFF signal is turned ON.

	X axis		Y axis	
	Special M/D	Buffer memory	Special M/D	Buffer memory
M code ON signal	M9051	#23(b3)	M9083	#25(b3)
M code OFF command	M9003	#20(b3)	M9019	#21(b3)
M code No.	D9003	#9003	D9013	#9013

\* Only the X axis is available in the FX-10GM.

\* In the FX-20GM or the FX-10GM, M codes can be transmitted with the FX/ FX2c Series programmable controller using buffer memories. (For details, refer to Section 8.)

The signals related to M codes can be output to an external unit using PARAs 36 to 38. (For details, refer to Section 4.4.2.)

### 5.1.4 Instruction execution time

Each instruction is executed at the times shown below.

Those which wait for completion of a machine operation.

cod 00(DRV)	cod 03(CCW)	cod 31(INT)
cod 01(LIN)	cod 28(DRVZ)	cod 71(SINT)
cod 02(CW)	cod 30(DRVR)	cod 72(DINT)

Those which wait for the M code OFF command input.

m01	(See note on next page.)
m03 ~ M99	

Those which wait for the start command input.

m00(WAIT)	m02(END)
m100(WAIT)	m102(END)

Note: This type of instructions can be started when the mode is changed over from MANU to AUTO by setting PARA. 104.

Those which wait for timeout of the timer.

cod 04(TIM)

Those which are executed immediately.

1 to 3 msec including the I/O refresh time and the special auxiliary relay refresh time.

cod 29(SETR)	FNC 00(CJ)	FNC 20(ADD)
cod 73(MOVC)	FNC 01(CJN)	FNC 21(SUB)
cod 74(CNTC)	FNC 02(CALL)	FNC 22(MUL)
cod 75(RADC)	FNC 03(RET)	FNC 23(DIV)
cod 76(CANC)	FNC 04(JMP)	FNC 24(INC)
cod 90(ABS)	FNC 09(BRET)	FNC 25(DEC)
cod 91(INC)	FNC 08(RPT)	FNC 26(WANT)
cod 92(SET)	FNC 09(RPE)	FNC 27(WOR)
	FNC 10(CMP)	FNC 28(WXOR)
LD LDI	FNC 11(ZCP)	FNC 29(NEG)
AND ANI ANB	FNC 12(MOV)	
OR ORI ORB	FNC 13(MMOV)	FNC 90
SET RET NOP	FNC 14(RMOV)	
	FNC 18(BCD)	
	FNC 19(BIN)	

Those which are processed by the time-sharing method.

FNC 72(EXT): 20 msec per digit of the digital switch (depending on the setting of PARA. 33). When execution of FNC 72 is completed, the next instruction is executed. Pay careful attention when using this instruction in a subtask.

FNC 74(SEGL): Three cycles of instruction execution is required per digit of the 7-segment display. This instruction is generally used in a subtask.

FNC 92(XAB): Approximately 500 msec to detect the absolute position using the MR-H servo motor. While FNC 92/93 is executed, all tasks are temporarily stopped until the absolute position is detected.

Those which wait for the check time.

cod 00(DRV)	cod 71(SINT)	Time after generation of pulses is finished until the positioning completion signal is received.
cod 09(CHK)	cod 72(DINT)	
cod 28(DRVZ)		
cod 30(DRVR)		

Start time of drive instructions.

The table below shows the start time after a drive instruction is executed until the motor actually starts to be driven. (Also, see note below.)

	cod00(DRV), cod30(DRVR) cod71(SINT), cod72(DINT)	cod28(DRVZ)	cod01(LIN), cod31(INT)	cod02(CW), cod02(CCW)
Independent 2-axis mode	17 to 25msec	25msec	-	-
Simultaneous 2-axis mode	17 to 40msec	40msec	150msec *1 (120) *3	170msec *2 (120) *3

\*1 When the M9015 is ON,  
120 + 30 N (msec) [ N: Number of continuous paths, 1 N 30 ]

\*2 When the M9015 is ON,  
120 + 50 N (msec) [ N: Number of continuous paths, 1 N 30 ]

\*3 (120) is the time (msec) after the continuous path interpolation is finished until program execution proceeds to the next instruction.

Note: Delays caused by FROM/TO

- The execution time for instructions sent from a programmable controller could be extended up to two times depending upon the time given to FROM/TO instruction execution in the position controller.
- It is recommended that the pulse execution type FROM/TO instruction is used to minimize communication overheads.

## 5.2 Drive Control Instructions

This section explains the drive control instructions which function as the basis of positioning control.

cod 00 DRV  DRIVE	<b>High speed positioning</b>				Applicable models	
	Servo end check	Yes	Remarks		Series name	Remarks
	Instruction group	A			● FX-10GM	
					● FX(E)-20GM	

Basic format	FX-20GM/E-20GM				FX-10GM			
	cod 00 DRV	x	fx * * *	y	fy	cod 00 DRV	x	fx * * *
		X axis target position	X axis operation speed	Y axis target position	Y axis operation speed		X axis target position	X axis operation speed

### DRIVE

This instruction specifies the travel to the target coordinates with independent settings for the X and Y axes (only one axis in the 10GM). The maximum speed and the acceleration/deceleration speed of each axis are set by parameters.

When single axis drive is used in the 20GM, specify only the X or Y axis target position.

### X axis target position

The target position is specified in units defined by PARA. 3 (minimum command unit).

Specification method	Set range
Direct specification	x0 ~ x± 999,999
Indirect specification (16-bit)	xD0 ~ xD6999 *1
Indirect specification (32-bit)	xDD0 ~ xDD6998 *1

\*1 D2000 to D3999 are not available in the 10GM.

Whether the position is incremental (distance from the present position) or absolute (distance from the zero point) is specified by the cod 91 (INC) or cod 90 (ABS) instruction.

Y axis target position ..... Same as for the X axis.

### Operation speed

Set these operands to operate the machine at a speed less than the maximum speed (set to PARA. 4). If these operands are not set, the machine operates at the maximum speed. When programming, use "f" only for both fx and fy.

Specification method	Set range
Direct specification	f0 ~ f± 200,000
Indirect specification (16-bit)	fD0 ~ fD6999 *2
Indirect specification (32-bit)	fDD0 ~ fDD6998 *2

\*2 D2000 to D3999 are not available in the 10GM.

### Program example

```
cod91(INC); Incremental
drive method
cod00(DRV)
x1000
f 2000;
```

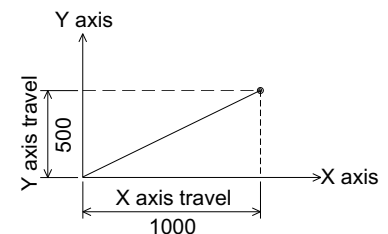
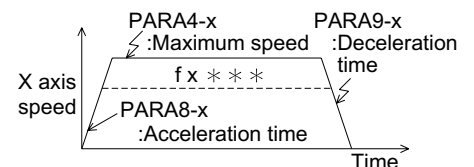
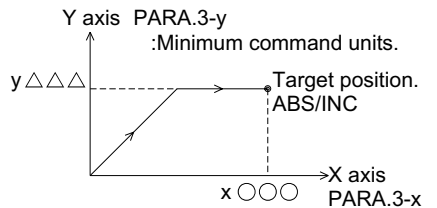
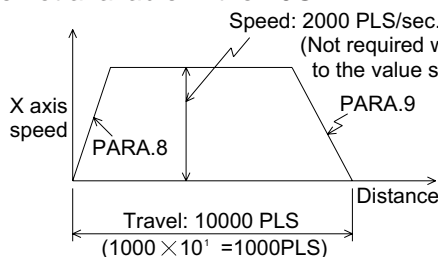

PARA. 0: System of units.  
Setting = "1"  
(motor system of units)  
PARA. 3: Minimum command unit  
Setting = "2" (10<sup>1</sup>)

cod 01 LIN  DRIVE	Linear interpolation positioning, Multi-step operation (10GM)		Applicable models	
	Servo end check	Yes	Remarks	
	Instruction group	A	Series name	Remarks
			● FX-10GM	
			● FX(E)-20GM	

Basic format	FX-20GM/E-20GM			<ul style="list-style-type: none"> <li>This instruction is not available in the programs (Ox, Oy and O100) for independent 2-axis operation and subtasks. If this instruction is used in one of these programs, it is ignored.</li> <li>In the FX-10GM (Ox), this instruction is used for multi-step operation.</li> </ul>
	cod 01 LIN	x	y	
		X axis target position	Y axis target position	Vector speed

**LINEAR**

This instruction specifies the travel to the target coordinates (X, Y) in the simultaneous 2-axis mode. If one of the axis coordinate values is not specified, 1-axis operation is performed at a speed specified by this instruction.

**X/Y axis target position**

The units for the target position is set by PARA. 3. The table below shows the set range for the both axes.

Specification method	Set range
Direct specification	x0 ~ x± 999,999
Indirect specification (16-bit)	xD0 ~ xD6999 *1
Indirect specification (32-bit)	xDD0 ~ xDD6998 *1

\*1 D2000 to D3999 are not available in the 10GM.

Whether the position is incremental (distance from the present position) or absolute (distance from the zero point) is specified by the cod 91 (INC) or cod 90 (ABS) instruction. When no value is given to x and y, the incremental travel is regarded as "0".

Pay careful attention to PARA. 23 (stop mode) when using this instruction.

**Vector speed**

Set the vector speed within the range shown in the table below. (The set value must not exceed the value set to PARA. 4.)

Specification method	Set range
Direct specification	f0 ~ f± 100,000
Indirect specification (16-bit)	fD0 ~ fD6999 *2
Indirect specification (32-bit)	fDD0 ~ fDD6998 *2

\*2 D2000 to D3999 are not available in the 10GM.

**Program example**

```
cod01(LIN)
x1000
y500
f 2000;
```

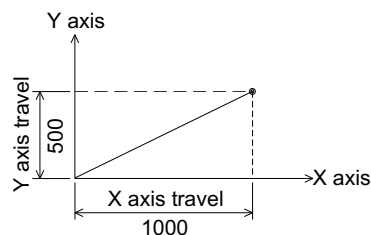

When the vector speed (f) is omitted, the machine operates at the following speed.

	10GM	20GM
1st time	200kpps	100kpps
2nd time or Later	Previous f value	Previous f value

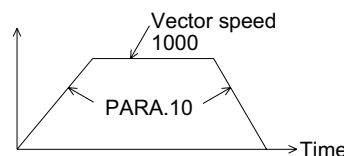

When interpolation instructions are consecutively executed, path operation is performed.

In the 10GM, multistep operation is performed (Refer to page 5-13).

cod 02 C W	Circular interpolation with center point specification			Applicable models	
	Servo end check	No	Remarks		
cod 03 C C W	Instruction group	A			
			Series name	Remarks	
			FX-10GM		
			● FX(E)-20GM		

Basic format	FX-20GM/E-20GM					
	cod 02 CW	x	y	i * * *	j	f
		X axis target position	Y axis target position	X axis center coordinate	Y axis center coordinate	Peripheral speed
	cod 03 CCW	x	y	i * * *	j	f
	X axis target position	Y axis target position	X axis center coordinate	Y axis center coordinate	Peripheral speed	

This instruction is not available in the programs (Ox, Oy and O100) for independent 2-axis operation and subtasks. If this instruction is used in one of these programs, it is ignored.

**CW/CCW**

This instruction specifies the travel to the target position around the center coordinates at the peripheral speed "f". When the start point is equivalent to the end point or when the endpoint coordinates (target coordinates) are not specified, the travel locus makes a complete circle.

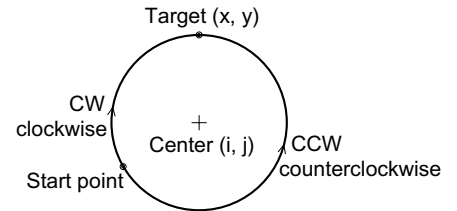

**X/Y axis target position (x, y)**

The target position can be specified by an incremental or absolute address. The units and the set range are equivalent to those for cod 00 and cod 01.

**X/Y axis center coordinates (i, j)**

The center coordinate always treated as an incremental address from the start point. The units and the set range are equivalent to those for cod 00 and cod 01.

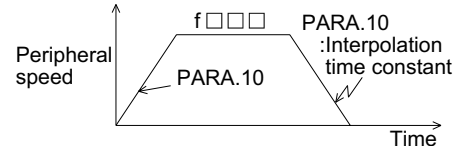

**Peripheral speed "f"**

Set the circular operation speed. The acceleration/deceleration time constant (PARA. 10) and the units of peripheral speed are equivalent to those for cod01.

Pay careful attention to PARA. 23 (stop mode) after using this instruction.

**Program example**

```
cod90(ABS); Absolute drive method.
cod02(CW)
x1000
y1000
i 250
j 250
f 1000;
```

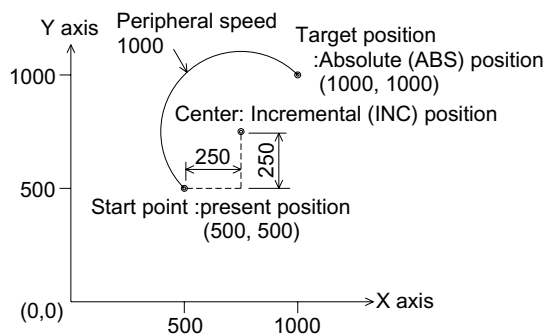

When interpolation instructions are executed consecutively, path operation is performed (Refer to page 5-13).

cod 02 C W	Circular interpolation with radius specification			Applicable models	
	Servo end check	No	Remarks	Series name	Remarks
cod 03 C C W	Instruction group	A		FX-10GM	
				● FX(E)-20GM	

Basic format	FX-20GM/E-20GM				
	cod 02 CW	x	y	r * * *	f
		X axis target position	Y axis target position	Radius	Peripheral speed
	cod 03 CCW	x	y	r * * *	f
	X axis target position	Y axis target position	Radius	Peripheral speed	

This instruction is not available in the programs (Ox, Oy and O100) for independent 2-axis operation and subtasks. If this instruction is used in one of these programs, it is ignored.

**CW/CCW**

This instruction specifies the travel to the target position around the center coordinates at the peripheral speed "f". The arc radius is specified by "r". When "r" is positive, the travel locus follows the short arc (A in the figures on the right). When "r" is negative, the travel locus follows the large arc (B in the figures on the right). Either a positive or negative radius can be used.

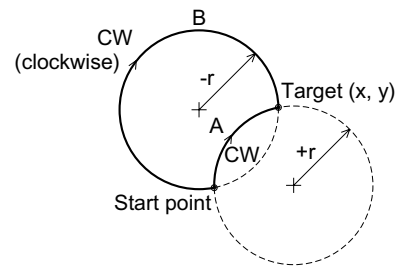

**X/Y axis target position (x, y)**

The target position can be specified by an incremental or absolute address. The unit and the set range are equivalent to those for cod 00 and cod 01.

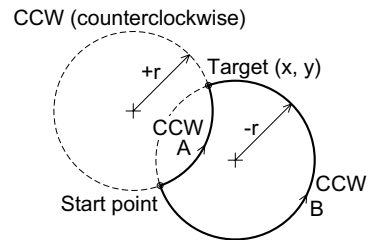

**Radius "r"**

The radius is always treated as an incremental address from the center point (which does not have to be set). The unit and the set range are equivalent to those for cod 00 and cod 01. Programs for true circles cannot be created using this instruction.

**Peripheral speed "f"**

Set the circular operation speed. The acceleration/deceleration time constant (set to PARA. 10) and the unit of peripheral speed are equivalent to those for cod 01. Pay careful attention to PARA. 23 (stop mode) after using this instruction.

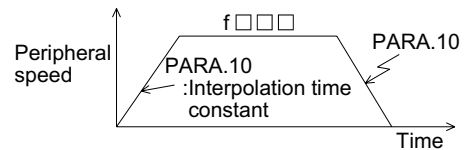

**Program example**

```
cod90(ABS); Absolute drive method.
cod02(CW)
x1000
y1000
i 250
j 250
f 1000;
```

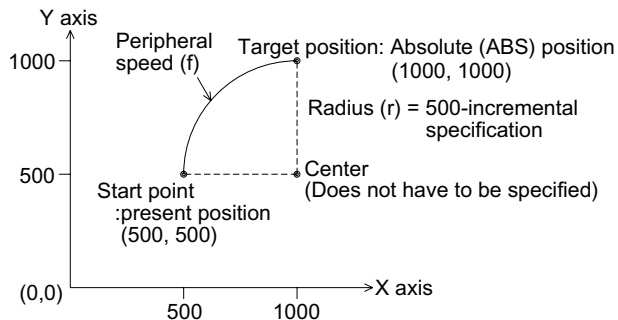

When interpolation instructions are executed consecutively, path operation is performed (Refer to page 5-13).



## Interpolation control and continuous paths (FX-20GM, E-20GM)

### Continuous paths

- Continuous paths indicate to consecutively execute the interpolation control instructions such as cod 01, cod 02 and cod 03.
- When any instruction other than applicable instructions (the cod 01, the cod 02 and the cod 03) is executed, continuous path operation is not performed. The machine is temporarily stopped, then proceeds to the next operation. (The machine is stopped in the following cases.)
  - When another cod instruction is executed.
  - When a sequence instruction is executed.
  - When an M code of the AFTER mode is executed.
  - When the cod 09 (CHK) servo end check instruction is executed (that is, when PARA. 21 is between 1 to 5000).

### Example of continuous paths

- cod 01 Linear interpolation (LIN)
- cod 02 Circular interpolation (CW)
- cod 01 Linear interpolation (LIN)
- cod 03 Linear interpolation (CCW)

### Continuous path operation

- Consecutive interpolation instructions are operated without stopping, and inflection points become smooth curves.
- The radius of curvature varies depending on the interpolation time constant (set to PARA. 10). A larger time constant makes a larger radius of curvature.
- In order to draw a precise locus, create a program using circular interpolation instructions.
- When the speed between each interpolation instruction is different, the composite speed of the current deceleration and the next acceleration is used.

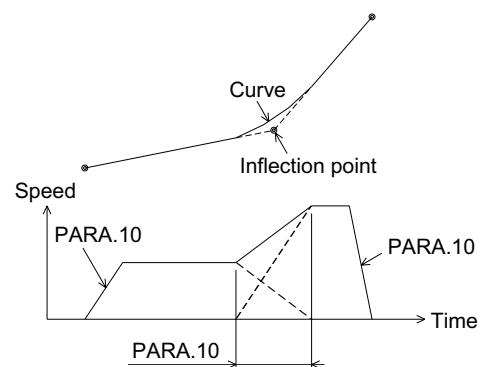

When this period becomes larger, the radius of curvature becomes larger.

### Number of continuous paths

- The number of continuous paths varies depending on the operation of the special auxiliary relay M9015.

When the M9015 is OFF

While an interpolation operation is performed, preparation for interpolation control for the next process is performed. Accordingly, there is no restriction in the number of continuous paths. However, if there is a short-time path as follows, the next process cannot be read in advance and the machine may temporarily stop its operation at this short-time path.

- Path whose travel time is 50 msec or less.
- Path whose travel time is the interpolation time constant or less.

When the M9015 is ON

For up to 30 continuous paths, preparation for interpolation control is preliminarily performed before the continuous paths are started. Accordingly, the machine never stops its operation if any short-time path is present. However, at the 31st path, the machine stops its operation temporarily, then starts the next continuous path.

When the number of continuous paths between the RPT and the RPE is 30 or less, repetitious operations are also continuously performed. For most operations, setting M9015 OFF is usual.

<p>The flag M9015 is not defined in FX-10GM and E-20GM whose version is 1.23 or earlier. In this case, the actual operation is performed as if M9015 is turned OFF in FX-10GM and as if M9015 is turned ON in E-20GM (of Ver. 1.23 or earlier).</p>
---

**Operations of M codes during continuous paths**

- When M codes of the WITH mode are specified in continuous path interpolation instructions, a series of continuous operations are performed even if the M code OFF command is not entered. When a series of operations are completed and the M code OFF command is entered, the machine proceeds to the next operation.
- When different M codes are specified in each interpolation drive instruction as in the program shown below, the M code outputs are switched one by one. Note that a new M code cannot be read if the M code OFF command is not given before the switching point.

**Program example**

```
cod 01 (operand) m10;
cod 01 (operand) m11;
cod 01 (operand) m13;
```

↑ Set the operands x, y, f, etc.

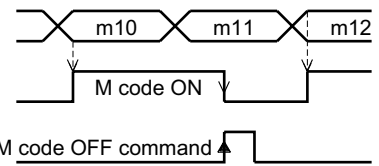

In the example above, a strobe to read m11 is not obtained.

**Other cautions and remarks**

**Incremental travel of interpolation control.**

- The incremental travel caused by one interpolation control instruction is restricted to 28 bits when converted into pulses.
- For example, when a travel of 1 μm per pulse is supposed, it corresponds to the incremental travel of 268 m.

**Stepping motor and continuous paths.**

- When a stepping motor is used to perform continuous path control, the motor may be out of order depending on the motor characteristics. It is recommended to stop the machine temporarily using the cod 09 (CHK) command.

**Interpolation control and pulse output format.**

- In interpolation control, PARA. 11 (pulse output format) must be set to "0".

**Remarks on circular interpolation.**

- During circular interpolation, the radius is constant and the pulses are distributed to the X and Y axes. Accordingly, if the ratio of the pulse rate and the feed rate (set to PARAs 1 and 2) is not equivalent in the X and Y axes, a deformed arc will be obtained. In this case, adjust the electronic gear of the servo amplifier to make the ratio equivalent in both the X and Y axes.
- When an arc is small and the travel time from the start point to the end point is shorter than the acceleration/deceleration time constant (set to PARA. 10), interpolation is impossible. In this case, the locus of the travel from the start point to the end point becomes linear instead of circular.

Multistep operation using continuous paths (FX-10GM).

- Though the cod 01 (LIN) is a linear interpolation instruction, it can be used for multistep operation by specifying continuous paths in the FX-10GM.

Program example

Create a program according to the operation example shown below.

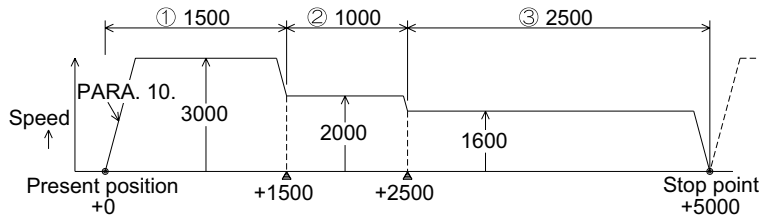

The travel can be specified by either the absolute drive method (ABS) or the incremental drive method (INC). However, when the drive method is changed during continuous paths, the machine stops temporarily.

Example of incremental drive

```

Ox00      Program No. 0
N0cod 91 (INC); Incremental drive method
N1cod 01 (LIN)
  x 1500
  f 3000;
N2cod 01 (LIN)
  X1000
  f 2000;
N3cod 01 (LIN)
  x 2500
  f 1600;
N4m02 (END) ] END command
    
```

Example of absolute drive

```

Ox00      Program No. 0
N0cod 01 (ABS); Absolute drive method
N1cod 01 (LIN)
  x 1500
  f 3000;
N2cod 01(LIN)
  x 2500
  f 2000;
N3cod 01 (LIN)
  x 5000
  f 1600;
N4m02 (END); ] END command
    
```

- In multistep operation, preparation for the next process is performed at the same time as the present process. Accordingly, when the available distance for change-over from the present operation speed to the next step speed is too small or when the travel time is short, the machine may not continue operation but is stopped temporarily.
- The number of multi-steps (number of continuous paths) is not restricted at all. The operations using M codes are performed in the same way as described for continuous paths on the previous page.
- In the FX-20GM or the E-20GM also, multistep operation is possible by specifying only one axis (X axis or Y axis) for operation. (In this case, however, only programs for simultaneous 2-axis operation are possible because interpolation control is required. The unspecified axis does not move.)

### 5.3 Standby Instructions

This section explains the instructions used to pause the machine during positioning.

cod 04 TIM  TIMER	Stabilization time (Dwell)		Applicable models	
	Servo end check	No	Remarks	
	Instruction group	B		
			Series name	Remarks
			<input checked="" type="radio"/> FX-10GM	
			<input checked="" type="radio"/> FX(E)-20GM	

Basic format	FX-20GM/E-20GM		FX-10GM					
	<table border="1"> <tr> <td>cod 04 TIM</td> <td>K * * *</td> </tr> </table> Stabilization time	cod 04 TIM	K * * *				<table border="1"> <tr> <td>cod 04 TIM</td> <td>K * * *</td> </tr> </table> Stabilization time	cod 04 TIM
cod 04 TIM	K * * *							
cod 04 TIM	K * * *							

#### TIMER

Use this instruction to set the waiting time between completion of one instruction and execution of another.

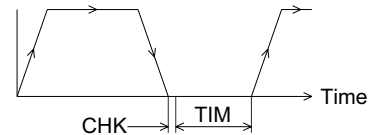

#### Stabilization time (Dwell)

The increment is 10 msec. "K100" indicates a delay of 1 second.

CHK: Servo end check  
TIM: Stabilization time

Specification method	Set range	Remark
Direct specification	K0 ~ K ± 65,535	Within range of 0 to 65,535.
Indirect specification (16-bit)	D6999 ~ D6999 *1	
Indirect specification (32-bit)	DC6998 ~ DC6998 *1	

\*1 D2000 to D3999 are not available in the 10GM.

SERVO END CHECK	<table border="1"> <tr> <th colspan="3">Servo end check</th> </tr> <tr> <td>Servo end check</td> <td>Yes</td> <td>Remarks</td> </tr> <tr> <td>Instruction group</td> <td>B</td> <td></td> </tr> </table>			Servo end check			Servo end check	Yes	Remarks	Instruction group	B		<table border="1"> <tr> <th colspan="2">Applicable models</th> </tr> <tr> <th>Series name</th> <th>Remrks</th> </tr> <tr> <td>● FX-10GM</td> <td></td> </tr> <tr> <td>● FX(E)-20GM</td> <td></td> </tr> </table>	Applicable models		Series name	Remrks	● FX-10GM		● FX(E)-20GM	
	Servo end check																				
	Servo end check	Yes	Remarks																		
Instruction group	B																				
Applicable models																					
Series name	Remrks																				
● FX-10GM																					
● FX(E)-20GM																					
Basic format	FX-20GM/E-20GM	FX-10GM																			
	cod 09 CHK	cod 09 CHK																			

**CHECK**

This instruction allows program execution to force a servo end check at the end of an interpolation operation, before the next operation is performed.

If interpolation operations are programmed consecutively, they are normally executed in non-stop operation and the inflection points draw a smooth curve. In order to move the machine to the target positions B and C, specify the cod 09 instruction after cod 01 to 03 instructions.

A servo end check is completed when the positioning completion signal (PF) is sent from the servo amplifier to the positioning unit. This happens when the number of deviation counter pulses in the servo amplifier has become smaller than the set value.

If the PF signal is not received within the time set to PARA. 21, a positioning error occurs.

PARA. 21 is set to "0" in the factory before shipment. This prevents the servo end check. When using the cod 09 (CHK) instruction, set an appropriate value to PARA. 21.

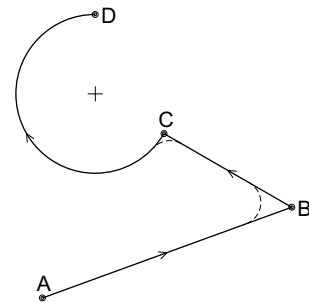

The servo end check is not performed for manual ZRN/FWD/RVS operation and pulse generator operation.

## 5.4 Zero Return Control Instructions

This section explains the machine zero return and the electrical zero return instructions.

cod 28 DRVZ  DRIVE TO ZERO	<b>Machine zero return</b>		Applicable models	
	Servo end check	Yes	Remarks	
	Instruction group	B		
Basic format	FX-20GM/E-20GM		FX-10GM	
	cod 28 DRVZ		cod 28 DRVZ	

### DRVZ

When this instruction is executed, a machine zero return operation is performed. (For details of the machine zero return operation, refer to Section 3.2.4.)

When a machine zero return operation is completed, the special auxiliary relays M9057 (X axis) and M9089 (Y axis) are turned ON (Only M9057 is available in the 10GM.).

When a machine zero return operation is performed once in the MANU or AUTO mode, these special auxiliary relays remain turned ON (They are turned OFF when the power is turned OFF.).

### Program

#### Example:

The following program uses the special Ms, described on the left, and a jump command to skip the zero return operation when the machine is restarted.

Ox00

LD M9057; Once a zero return operation has been completed, program execution jumps.  
 FNC 00 (CJ) P0; ←  
 cod 28 (DRVZ);  
 P0; ←

- In simultaneous 2-axis operation in the FX-20GM or the E-20GM, this instruction returns both the X and Y axes to the zero point simultaneously. To return only one axis to the zero point, refer to the following program example.  
 M9008: Prohibits the machine zero return operation of the X axis.  
 M9024: Prohibits the machine zero return operation of the Y axis.  
 These settings are valid in the FX(E)-20GM Ver. 3 or later manufactured in May, 1995 or later.

#### Example:

(Only X axis is returned to the zero point first, then the Y axis is returned to the zero point.)

O0, N0 (simultaneous 2-axis program)

SET M9024 ;Prohibits zero return operation of Y axis.

cod 28 (DRVZ);Returns X axis only to zero point.

(M9008 = OFF, M9024 = ON)

RST M9024 ;Allows zero return operation of Y axis.

SET M9008 ;Prohibits zero return operation of X axis.

cod 28 (DRVZ);Returns Y axis only to zero point.

(M9008 = ON, M9024 = OFF)

RST M9008 ;Allows zero return operation of X axis.

cod 28 (DRVZ);Returns both X and Y axes to zero point.

(M9008 = OFF, M9024 = OFF)

Note: When both M9008 and M9024 are turned ON, no operation is performed even if cod 28 is executed.

The zero return completion flags (M9057, M9089) are not turned ON when zero return is prohibited for the corresponding axis.

cod 29 SETR	<b>Electrical zero point setting</b>			Applicable models	
	Servo end check	No	Remarks	Series name	Remarks
SET RETURN ADDRESS	Instruction group	B		<input type="radio"/> FX-10GM	
			<input type="radio"/> FX(E)-20GM		

Basic format	FX-20GM/E-20GM	FX-10GM
	cod 29 SETR	cod 29 SETR

**SETR**

When this instruction is executed, the present position (set to the present value register) is written to the electrical zero point register.

cod 30 SETR	<b>Electrical zero return</b>			Applicable models	
	Servo end check	Yes	Remarks	Series name	Remarks
DRIVE TO RETURN ADDRESS	Instruction group	B		<input type="radio"/> FX-10GM	
			<input type="radio"/> FX(E)-20GM		

Basic format	FX-20GM/E-20GM	FX-10GM
	cod 30 DRVR	cod 30 DRVR

**DRVR**

When this instruction is executed, the machine returns to the electrical zero point (set to the electrical zero point register) at a high speed, and the servo end check is performed. The acceleration/deceleration time is determined by PARA. 8 and PARA. 9, and the operation speed is determined by PARA. 4 (maximum speed).



## 5.5 Interrupt Drive Instructions

The inputs shown in the table below are assigned as the stop commands and deceleration commands for interrupt drive control.

Input	FX(E)-20GM	FX-10GM	Remarks
X00	cod72 : X axis 1	cod72 : X axis 1	
X01	cod72 : X axis 2	cod72 : X axis 2	
X02	cod72 : Y axis 1	cod71 : X axis	
X03	cod72 : Y axis 2	cod31	
X04	cod71 : X axis		
X05	cod71 : Y axis		
X06	cod31 : Simultaneous 2-axis		
X07			

The input filters for the above inputs are automatically reduced to 0.1 msec and correspond to high speed inputs when cod 31, cod 71 or cod 72 is used (only in the 20GM).

Because these inputs are treated as general-purpose inputs and can also be used with a manual pulse generator they may not be available. (Refer to PARA. 39 (manual pulse generator) described in Section 4.4.3.)

cod 31 INT	Interrupt stop (ignoring the remaining distance)			Applicable models	
	Servo end check	No	Remarks	Series name	Remarks
INTERRUPT STOP	Instruction group	A		● FX-10GM	
				● FX(E)-20GM	

  

Basic format	FX-20GM/E-20GM			FX-10GM			
	cod 31 INT	X	Y	f	cod 31 INT	X	f
	X axis target position	Y axis target position	Vector speed	X axis target position	Speed		

**INT**

**In the FX(E)-20GM**

Linear interpolation operation is performed to the target coordinates (x, y) at the vector speed (f). When the interrupt input X06 (fixed) is turned ON, positioning is aborted, the machine is decelerated and stopped, then the next instruction is executed. This instruction is available only in the simultaneous 2-axis mode (O00 to O99).

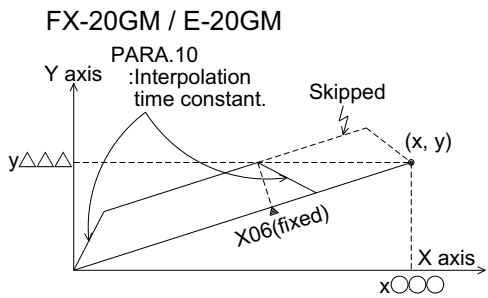

**In the FX-10GM**

Positioning is performed to the target position (x000) at the speed (f). When the interrupt input X3 (fixed) is turned ON, positioning is aborted, the machine is decelerated and stopped, then the next instruction is executed.

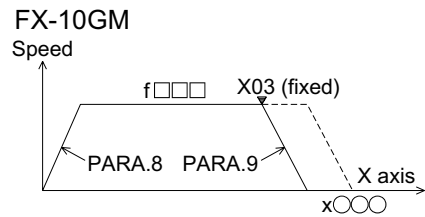

**X/Y axis target position**

The position can be specified by either the incremental address or the absolute address. The unit and the set range are equivalent to those for the cod 01.

**Speed**

The unit and the set range are equivalent to those for the cod 01.

**Program example (in the FX(E)-20GM) :**

```
cod 31 (INT)
x 1500
y 1000
f 2000;
cod 01 (LIN)*2
x 2000
y 1500
f 2000;
```

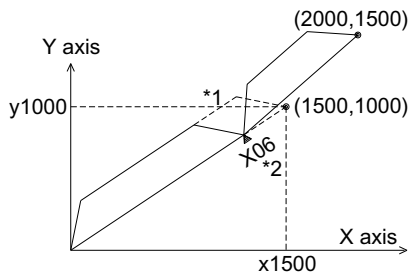

\*1 When the interrupt input X06 is turned ON, the machine is decelerated and stopped. Then, the machine proceeds to the next positioning while ignoring the remaining distance indicated in dotted line.

\*2 The machine moves to the target position if input X06 is not turned ON.

cod 71 SINT	Interrupt jog feed (one-step speed)			Applicable models	
	Servo end check	Yes	Remarks	Series name	Remarks
INTERRUPT STOP	Instruction group	B		● FX-10GM	
			● FX(E)-20GM		

Basic format	FX-20GM/E-20GM			FX-10GM		
	cod 71 SINT	x	fx * * *	cod 71 SINT	x	fx * * *
		X axis incremental distance	Speed		X axis incremental distance	Speed
		,			,	
	cod 71 SINT	y	fy			
		Y axis incremental distance	Speed			
		,				

**SINT**

The machine operates at the speeds  $f_x$  and  $f_y$  until the interrupt inputs are turned ON. When the interrupt input is turned ON, the machine travels the specified distance without changing speed and then stops.

Interrupt inputs

X04 (X axis), X05 (Y axis): FX(E)-20GM

X02 (X axis): FX-10GM

The machine continues to travel without restriction until the interrupt inputs are turned ON.

**X/Y axis incremental travel**

Though the units and the set range are equivalent to those for the cod 00 (DRV), the specified numeric is always treated as an incremental address.

**X/Y axis speed**

The units and the set range are equivalent to those for the cod 00. However, the settings cannot be omitted.

**Program example**

```
cod90(ABS); Incremental address.
cod71(SINT)
  x1000*1
  f 2000;
```

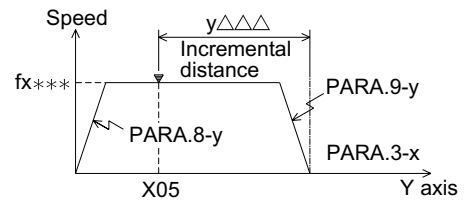
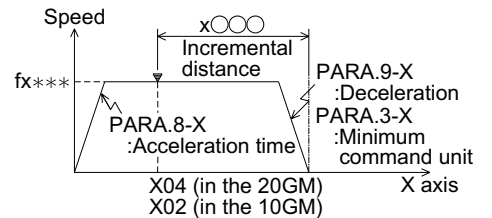

Pay attention to PARA. 23 (stop mode).

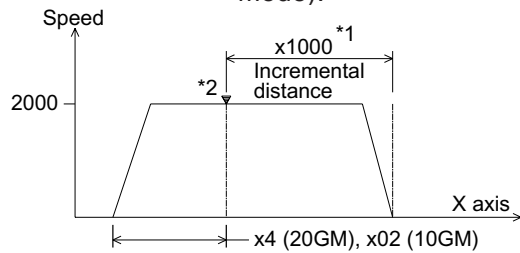

\*1 Even if the absolute drive method is used in the program, the travel is treated as incremental address after the cod 71 is executed.

\*2 When the incremental travel is small and the specified speed is high, the servo motor drastically decelerates and the machine is stopped at the specified position (If the machine has gone too far, the travel direction is reversed.). Be careful if using a stepping motor as it may become out of order.

cod 72 DINT	Interrupt jog feed (two-step speed)			Applicable models	
	Servo end check	Yes	Remarks	Series name	Remarks
INTERRUPT STOP	Instruction group	B		● FX-10GM	
				● FX(E)-20GM	

Basic format	FX-20GM/E-20GM						FX-10GM							
	cod 72 DINT	X	fx***	fx	X axis one-step speed			cod 72 DINT	X	fx***	fx	X axis one-step speed		
			X axis incremental distance	First-step speed	Second-step speed				X axis incremental distance	First-step speed	Second-step speed			
			,	"					,	"				
	cod 72 DINT	y	fy***	fy	Y axis one-step speed									
			Y axis incremental distance	First-step speed	Second-step speed									
			,	"										

**DINT**

The machine operates at the first-step speed  $fx^{***}$  or  $fy^{***}$  until the interrupt input is turned ON.

When the speed-change input is turned ON, the operation speed is changed into the second-step speed  $fx^{***}$  or  $fy^{***}$ .

And when the stop input is turned ON, the machine performs incremental travel of the specified distance, then stops.

Speed-change inputs      Stop inputs  
 X00 (X axis)              X01 (X axis)      FX(E)-20/10GM  
 Y02 (Y axis)              Y03 (Y axis)      FX(E)-20GM

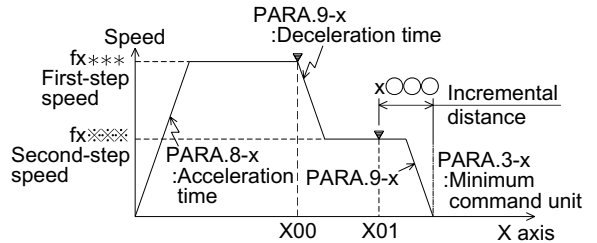

The machine continues operation without restriction until both the speed-change input and the stop input are turned ON.

**X/Y axis incremental travel**

The units and the set range are equivalent to those for cod 00 (DRV). However, the settings are always treated as incremental values and cannot be omitted.

**X/Y axis speed**

The units and the set range are equivalent to those for cod 00 (However, the settings of the travel and the speed cannot be omitted.). The second-step speed can be set higher (faster) than the first-step speed.

However, when the travel distance is short and the travel is finished within the deceleration time set to PARA. 9, the machine stops immediately. In this case, a stepping motor (if used) may become out of order.

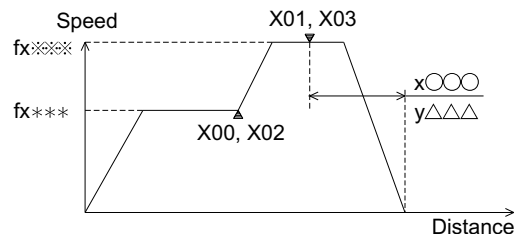
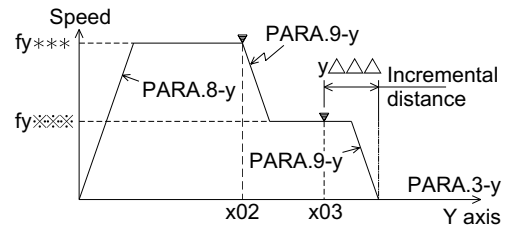

## 5.6 Compensation

This section explains the instructions related to compensation of the position coordinates used for positioning.

cod 73 MOVC	Travel compensation/Center point compensation/ Radius compensation/Compensation cancel		Applicable models	
cod 74 CNTC	Servo end check	No	Remarks	
cod 75 RADC	Instruction group		C	
cod 76 CANC				

Basic format	FX-20GM/E-20GM		FX-10GM	
	cod 73 MOVC	x y	Travel compensation	cod 73 MOVC x
		X axis target position Y axis target position		X axis target position
	cod 74 CNTC	i * * * j	Center point compensation	
		X axis center position Y axis center position		
cod 75 RADC	r	Radius compensation		
	X axis incremental dosition			
cod 76 CANC		Compensation cancel	cod 76 CANC	

### MOVC

Compensation is performed to the travel (target distance) performed after this instruction.

### CNTC

Compensation is performed to the center point specified by the cod 02 and cod 03 instructions executed after this instruction.

### RADC

Compensation is performed to the radius specified by the cod 02 and cod 03 instructions executed after this instruction.

### CANC

The compensations to above are canceled.

### Compensation values

A compensation value can be set in the range 0 to ±999,999.

The present address does not include a compensation value.

### Program example

```

cod91(INC); Specifies the incremental
            travel method.
cod00(DRV) Moves the machine to Point A.
x1000;
cod73(MOVC) Compensates the travel.
x10; Sets the X axis compensation
value to "10".
cod00(DRV) Moves the machine to Point B.
x1500;
cod76(CANC) Cancels compensation.
    
```

Acceleration is determined by PARA. 8 and PARA. 9.

The operation speed is determined by PARA. 4 (maximum speed).

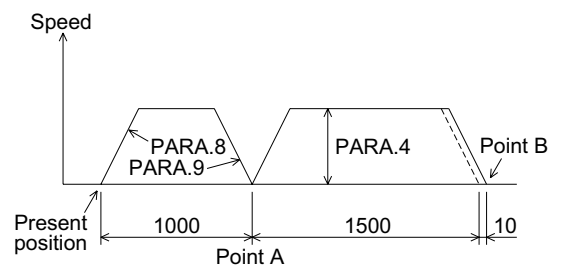

## 5.7 Address Specification and Present Value Change Instruction

This section explains the address specification and the present value change instruction.

cod 90 ABS	<b>Absolute/Incremental address</b>		Applicable models	
cod 91 INC	Servo end check	No	Remarks	
	Instruction group	D		
			Series name	Remarks
			● FX-10GM	
			● FX(E)-20GM	

Basic format	FX-20GM/E-20GM		FX-10GM
	cod 90 ABS	Absolute address	cod 90 ABS
	cod 91 INC	Incremental address	cod 91 INC

### ABS

The address coordinates (x, y) used after the cod 90 instruction are regarded as absolute values from the zero point (0, 0).

However, the coordinates of the arc center point (i, j), the radius (r), the travel by cod 71 (SINT) and cod 72 (DINT) are always regarded as incremental values.

An address is regarded as an absolute value when specification is omitted.

### INC

The address coordinates (x, y) used after the cod 91 instruction are regarded as incremental values from the present position.

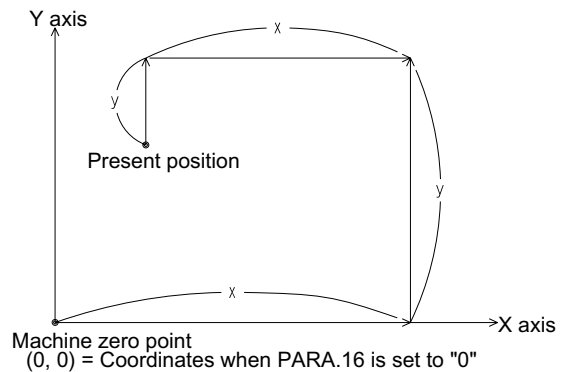

cod 92 SET	<b>Present value change</b>			Applicable models	
	Servo end check	No	Remarks	Series name	Remarks
	Instruction group	B		<input checked="" type="radio"/> FX-10GM	
SET			<input checked="" type="radio"/> FX(E)-20GM		

  

Basic format	FX-20GM/E-20GM			FX-10GM	
	cod 92 SET	x	y	cod 92 SET	x
		X axis present value	Y axis present value		X axis present value

When this instruction is executed, the value in the present value register changes to the value specified by this instruction. Accordingly, both the machine zero point and the electrical zero point are also shifted.

**Example:**

The figure on the right indicates the new and old origin before and after "cod 92 (SET) x400, y200" is executed in the present position (300, 100) (absolute coordinates).

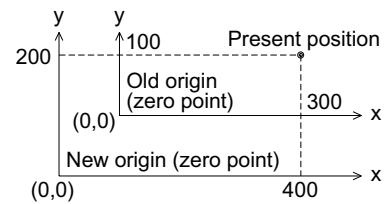

## 5.8 Subtasks

This section explains the subtask which mainly processes programmable controller programs.

### Main tasks and subtasks

- A main task is a positioning program expressed as O, Ox and Oy which performs positioning in the simultaneous 2-axis mode or independent 2-axis mode (Ox exclusively is available in the 10GM.).
- A subtask is a program which mainly consists of sequence instructions and does not perform positioning control.

<p>Main tasks</p> <p>Positioning programs</p> <ul style="list-style-type: none"> <li>• Simultaneous 2-axis</li> <li>• X axis</li> <li>• Y axis main task</li> </ul>
---

<p>Subtasks</p> <p>Sequence programs</p>
--

- There are two or more main programs, and the program to be executed can be selected using PARA. 30 (program No. specification). Only one subtask can be created. The selected main tasks and the subtask are executed simultaneously.

### Rules for subtasks

Subtask program

This portion is called a subtask program.	O100 ..... Start of subtask program
	}
	m100 ..... Temporary stop (WAIT)
	}
	m102 ..... End (END)

- **Specifying the subtask**  
The program No. of any subtask is O100 which must be included in the first line. Add "m102 (END)" at the end of a program. Use "m100 (WAIT)" for a temporary stop. "m102" and "m100" are fixed.
- **Subtask program position**  
A subtask can be created in any position in the program area (Steps 0 to 3799 or 0 to 7799) of the positioning unit. It is recommended for easy recognition to create it after the positioning program.

- **Subtask start/stop**  
Start, stop, single-step operation, etc. of a subtask are set by parameters (Refer to Section 4.2.2.).  
For special auxiliary relays and special data registers for subtasks, refer to Section 4.5



**Processing of subtasks**

Program example:

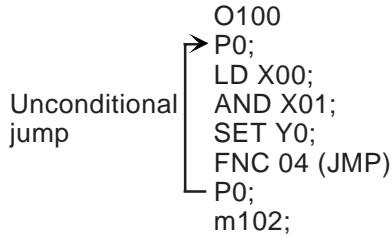

Note: The subtask processing speed is approximately 1 to 3 msec per line. It is recommended to restrict the number of lines to approximately 100 when the subtask is processed repeatedly so that the operation time does not become too long.

- The subtask is processed one line at a time in the same way as a positioning program. When the START signal is entered, the subtask is processed from the first line, and finishes at "m102 (END)" then waits for the next START signal. For cyclic operation, use a jump instruction such as FNC04 (JMP) as shown in the example on the left. However, jumping from the subtask to a positioning program (main program) is impossible.

- Inside a subtask, all the sequence and application instructions (described in Section 5) and the following cod instructions are valid.

cod 04 (TIM)	Dwell
cod 73 (MOVC)	Travel compensation
cod 74 (CNTC)	Center point compensation
cod 75 (RADC)	Radius compensation
cod 76 (CANC)	Compensation cancel
cod 92 (SET)	Present position change

Attention must be paid when the cod 04 (TIM) is used in repetitious operations because program execution waits for the dwell time then proceeds to the next step.

M code outputs are not available. The m100 (WAIT) and the m102 (END) only are valid instructions.

**Program examples**

- Two examples of subtask programs are shown below. Note that processes which would take a long time if performed in a positioning program and controls other than positioning control are best handled by the subtask.

Fetching the digital switch data

```

O100
N00 P255;
N01 FNC74 (SEGL) X0 Y0 D9004 K4;
N02 FNC04 (JMP) P255;
N03 m102 (END)
    
```

Error detection output

```

O100
N00 P255;
N01 LDI M9050
N02 ANI M9082
N03 FNC90 (OUT) Y00
N04 FNC04 (JMP) P255;
N05 m102 (END)
    
```

- The example on the left displays the lower 4 digits of the X-axis current position.

In a similar manner anything not directly connected to positioning operations can be programmed in the subtask program.

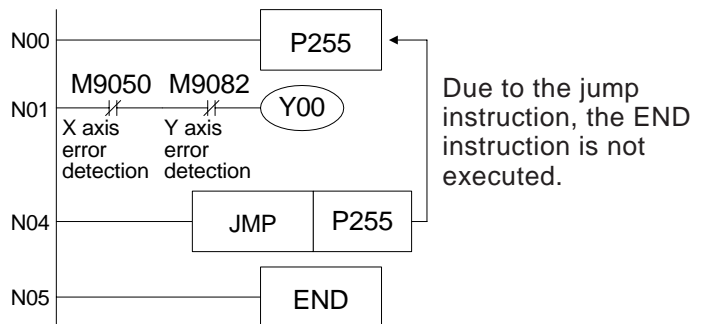

- The program above turns OFF the normal output Y00 when detecting an error in either the X or Y axes.

# MEMO

# 6. SEQUENCE CONTROL INSTRUCTIONS

This section explains the basic (LD, AND, etc.) and application instructions for sequence control.

These instructions are used together with the positioning control instructions described in the previous section, to control auxiliary equipment required for positioning.

## 6.1 Applicable devices

The following devices are used for sequence control instructions.

**Table:6.1 Applicable devices**

	FX-20GM		FX-10GM	*4
	Main unit		Main unit	
Input relays (X)	X00 to X07	8 points	X00 to X03	4 points
	*5 X372 to X377	6 points *1	X375 to X377	3 points *1
Output relays (Y)	Y00 to Y07	8 points	Y10 to Y67	48 points *2
Auxiliary relays (M)	M0 to M99 (general purpose)	100 points	M0 to M511	512 points
	M100 to M511 (general purpose)	412 points *3	(general purpose)	
	M9000 to M9175 (special)		M9000 to M9175 (special)	
Data registers (D)	D0 to D99 (general purpose)	100 points	D0 to D1999	2000 points
	D100 to D3999 (general purpose)	3900 points *3	(general purpose)	
	D4000 to D6999 (files)	3000 points *3	D4000 to D6999 (files)	3000 points
	D9000 to D9599 (special)		D9000 to D9313 (special)	
Index registers	V0 to V7 (16-bit)	8 points	V0 to V7 (16-bit)	8 points
	Z0 to Z7 (32-bit)	8 points	Z0 to Z7 (32-bit)	8 points
Pointers	P0 to P255	256 points	P0 to P127	128 points

\*1 When PARA. 56 (general purpose declaration) is set to "1" to "4", the [ZRN], [FWD] and [RVS] terminals can be used for general purpose inputs (Refer to Section 4.4.5).

\*2 Lower numbers are assigned to extension blocks from the one closest to the FX(E)-20GM main unit. The total number of extension I/Os must be 48 or less (Refer to Section 1.3).

### Example of I/O assignment

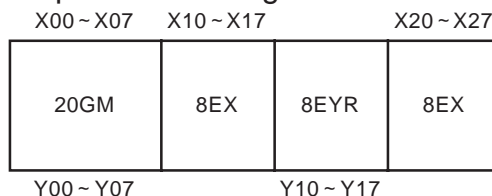

For the power consumption of the 24 VDC service power supply when extension blocks are connected, refer to Section 2.5.2.

\*3 Battery backup area (The data saved in this area is backed up by the F2-40BL battery even when the power is turned OFF.)

\*4 The use of extension blocks is not possible with the FX-10GM. When more I/Os are required, use a programmable controller.

\*5 When manual pulse generators or interrupt positioning instructions (cod 31, cod 71 and cod 72) are used, a part or the whole of these cannot be used for general purpose inputs (Refer to Section 5.5).

## 6.2 Basic sequence instructions

The sequence instructions are classified into the basic type and the application type. The format of both types is equivalent to that for the FX Series programmable controller. These sequence instructions are used in positioning programs (including subtasks).

**Table:6.2 Basic instruction list**

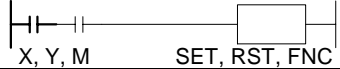
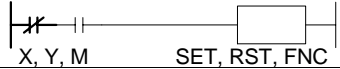
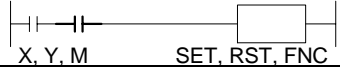
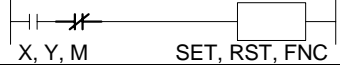
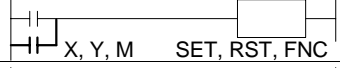
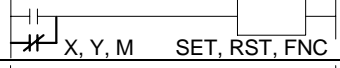
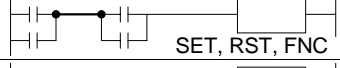
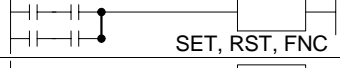
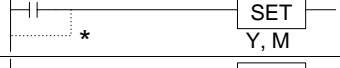
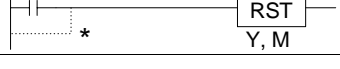
Symbol and name	Function	Circuit indication and applicable devices	Description
LD Load	Operation start NO contact	 X, Y, M SET, RST, FNC	<ul style="list-style-type: none"> <li>The contact instructions shown on the left are used to drive coil instructions such as SET, RST, and the application instructions described later.</li> <li>The applicable devices are contacts of X (input relay), Y (output relay) and M (auxiliary relay).</li> <li>For example, when "LD X00" is encountered, program execution is not held until the X00 is turned ON; the ON or OFF status of the X00 is detected and the next step is immediately executed. (This is true for all contact instructions.)</li> </ul>
LDI Load inverse	Operation start NC contact	 X, Y, M SET, RST, FNC	
AND And	Series connection NO contact	 X, Y, M SET, RST, FNC	
ANI And inverse	Series connection NC contact	 X, Y, M SET, RST, FNC	
OR Or inverse	Parallel connection NO contact	 X, Y, M SET, RST, FNC	
ORI Or inverse	Operation start NC contact	 X, Y, M SET, RST, FNC	
ANB And block	Series connection between blocks	 SET, RST, FNC	There are no applicable devices for the ANB (Series connection between parallel circuit blocks) and ORB (parallel connection between series circuit blocks) instructions.
ORB Or block	Parallel connection between blocks	 SET, RST, FNC	
SET Set	Operation-maintaining coil instruction	 * SET, Y, M	<ul style="list-style-type: none"> <li>Once the SET instruction is driven by turning its contact ON, it remains operational until the instruction is driven by turning its contact OFF.</li> <li>The applicable devices are coils of Y and M.</li> </ul>
RST Rset	Operation-canceling coil instruction	 * RST, Y, M	
NOP No operation	No operation	Used to erase a program or enter spaces.	

\* Can be driven even without a contact instruction.

Differences to the operations of the programmable controller.

- ```

N100 LD X00
N101 SET Y00

```

Different to the cyclic operations of the programmable controller, the basic sequence instructions are single-step type. In the example on the left, after line N100 has been executed, Y00 will not be output even if X00 is turned ON. To perform cyclic operations, use the jump instructions described later (Section 6.4).
- ```

N200 LD X00
N201 cod 00 (DRV)
      x 1000;

```

A contact instruction has nothing to do with the control instructions (cod instructions) for positioning. In the example on the left, cod 00 in line N201 is executed regardless of the ON/OFF status of X00 in line N200.

## 6.3 General rules for application instructions

This section explains the items common to all application instructions.

### 6.3.1 Application instruction format

In this manual, each application instruction is expressed as follows.

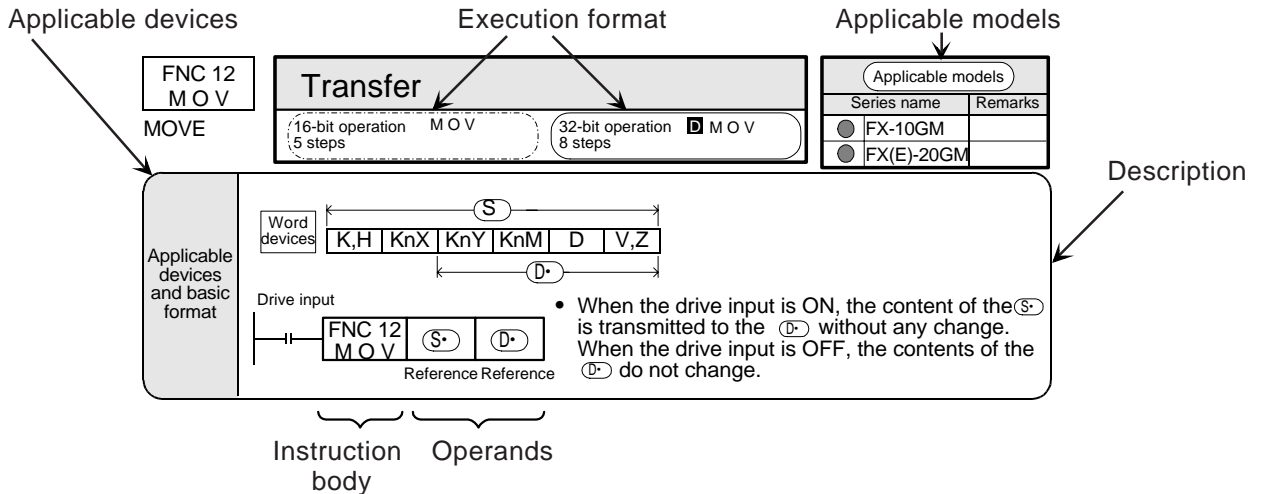

#### Applicable models

The models in which the described instruction is available are indicated.

The models are classified into the FX-10GM and the FX(E)-20GM. "●" is added to the applicable series.

#### Instruction body

An application instruction is specified by the function No. FNC 00 to the FNC 93. To each instruction, a symbol (mnemonic or instruction symbol) which represents the contents is assigned. For example, "MOV" is assigned to the FNC 12.

Some application instructions only require the instruction body. In most cases, however, the instruction body is combined with one or more operands which follow it.

#### Operands

The operands specify the condition and the contents required to execute the instruction. Specify the operands in the order stated.

##### S: Source

The operands whose contents are not changed by execution of the instruction are called sources and are identified by the symbol (S). If a source operand can be indexed (as described later), it is followed by "." and indicated as (S.). When there are two or more sources, they are indicated as (S1.), (S2.), etc.

##### D: Destination

The operands whose contents are changed by execution of the instruction are called destinations and are identified by the symbol (D). If a destination operand can be indexed (as described later), it is followed by "." and indicated as (D.). When there are two or more destinations, they are indicated as (D1.), (D2.), etc.

##### n: Constant

The operands for which only constant K or H can be specified are indicated as "n". When there are two or more constants, they are indicated as n1, n2, etc.

Applicable devices

- Devices such as X, Y, M and D can be used as operands.
- X, Y and M can be used as bit devices or word devices (Refer to "6.3.2 Bit devices".).
- The data registers D (16-bit) and the index registers V (16-bit) and Z (32-bit) are handled as data.

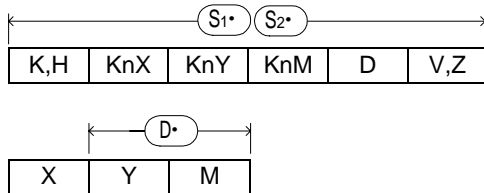

The expression shown on the left indicates that constants K and H, group bit devices KnX, KnY and KnM, data registers D and index registers V and Z are applicable as operands  $\text{S1}$  and  $\text{S2}$ . And this expression also indicates that bit devices Y and M can be specified as  $\text{D}$ .

- The indexes V0 to V7 and Z0 to Z7 cannot be further indexed. (For example, V0Z is invalid.)

Execution format

The instructions handling 16-bit numbers as well as 32-bit numbers are indicated by prefixing the symbol **D** (Refer to "6.3.3 Data length and instruction execution format".).

Description

The basic contents such as what the instruction can do, how the operands must be set, etc. are described here.

Application instruction drive input

- An application instruction can either be driven via some contact or directly driven without regard to any contact. The instructions FNC 03 to FNC 09 are exceptions, and are always driven directly without regard to any contact.
- In the case of an application instruction which is driven via some contact, it is not executed when the drive input is OFF (as if the instruction is skipped by the jump function.)
- The contact circuits are automatically reset when a positioning control instructions, M code instructions, FNC 03 to FNC 05, FNC 08 and FNC 09, etc. are specified in the program. After that, program execution returns to the bus line.

### 6.3.2 Bit devices

- The devices such as X, Y, M and K which handle ON/OFF information are called bit devices. Other devices such as D, V and Z which handle numeric data are called word devices. Bit devices, however, can be grouped to handle numeric data. The combination of bit devices is expressed by a digit "n" following "K" (Kn) and the head device No. The bit devices can be grouped in unit of 4 bits. The "n" in KnM0 defines the number of groups of 4 bits to be combined for data operation.

- K1 to K4 are allowed for 16-bit data operation, and K1 to K8 are allowed for 32-bit data operation.

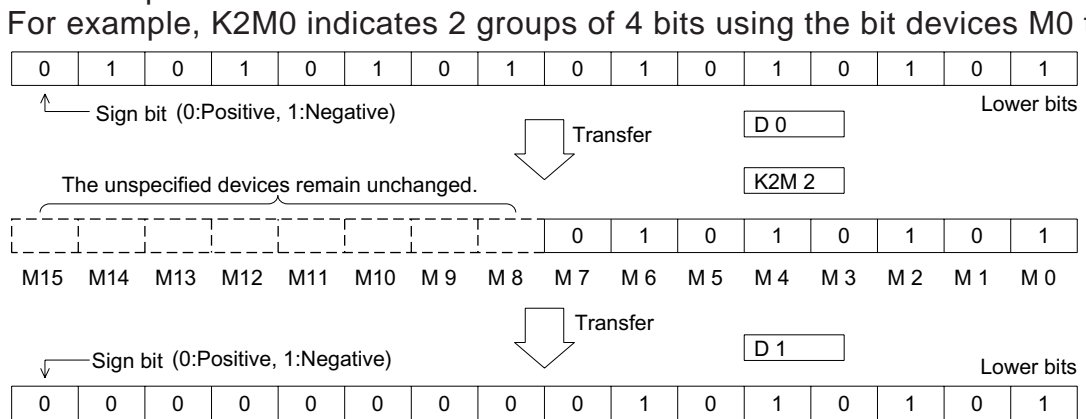

- When 16-bit data is transmitted to K1M0 to K3M0, the overflowing bit data is not transmitted. This is also true for 32-bit data.
- When a 16-bit (32-bit) data operation is executed and the digit specification for a bit device is K1 to K3 (K1 to K7), "0" is placed in the higher digit bit positions. For example, if K4Y00 is used for a 32 bit data operation, the upper 16 bits are regarded as "0". If 32-bit data with the sign is required, K8Y00 must be specified.
- Any bit device No. can be used. However, it is recommended to use "0" in the lowest digit place of the X and Y No. (X00, X10, X20 . . . , Y00, Y10, Y20, etc.). For M, it is ideal to use multiples of 8. However, because the use of such No. may lead to confusion in assigning device No., it is recommended to use multiples of 10 such as M0, M10, M20, etc. in the same way as X and Y.

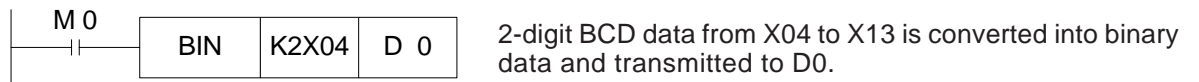

#### Specification of series of words

A series of data registers beginning with D1 means D1, D2, D3, D4, . . . .  
 When grouped bit devices are used for a series of words, they will be specified in the following way.

K1X00, K1X04, K1X14, . . . ;                    K2Y10, K2Y20, K2Y30, . . . ;  
 K3M0, K3M12, K3M24, K3M36, . . . .

That is, all bit devices will be used so that no device is skipped.

### 6.3.3 Data length and instruction execution format

- Application instructions which handle numerics are either 16-bit or 32-bit depending on the bit length of the numeric data.

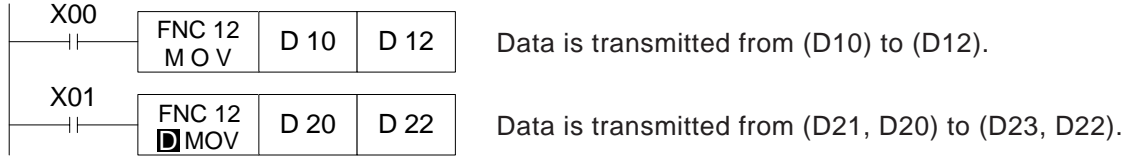

- 32-bit instructions are indicated by prefixing the symbol **D** as **D MOV**, FNC **D** 12, FNC12 **D**, etc.

In this case, numeric data is handled as follows.

Kn of grouped bit devices such as KnX, KnY and KnM can be assigned values from K1 (4 bits) to K8 (32 bits).

Using an even No. data register for the lower 16 bits, the succeeding data register is used for the upper 16 bits. Specify the lower device for operands. Z index registers should be used when specified as the operand with 32-bit instructions.

- In the same way as general data registers, the file registers can be used in various instructions.

### 6.3.4 Indexing of devices

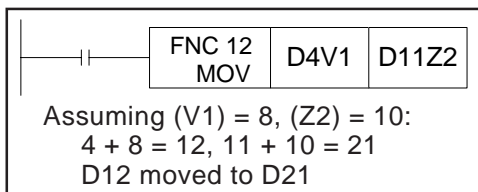
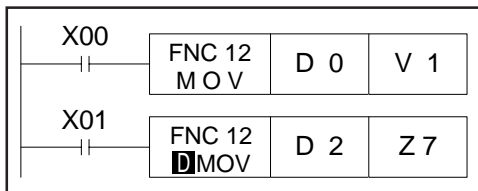

Modifiable devices:  
 X, Y, M, P (pointer), KnX, KnY,  
 KnM, D

- The index data registers V and Z are 16-bit or 32-bit data registers which allow writing and reading of numeric data in the same way as general registers.
- The registers V are used as 16-bit operand, and the registers Z are used as 32-bit operands.
- Changing of a device No. in accordance with the contents of V or Z, as shown in the figure on the left, is called "indexing" of the device No.
- The registers V and Z, when indexing devices, can be used together without any distinction between 16-bit and 32-bit instructions.
- The devices that can be modified by the index registers are those used in application instructions as shown on the left.
- However, "Kn" of group bit devices and the jump destination label No. "P" cannot be modified.



## 6.4 Program Flow

<b>FNC 00</b> <b>C J</b> CONDITIONAL JUMP	<b>Conditional jump</b>	Applicable models	
	16-bit operation CJ 3 steps	Series name	Remarks
		● FX-10GM	
		● FX(E)-20GM	

Applicable devices and basic format

S• : Pointers P0 to P127 (in the 10GM) P0 to P255 (in the 20GM) ( Pointers used for CALL instructions should not be used for JUMP instructions.

- When the drive input condition is satisfied, program execution jumps to the specified label.

### Example

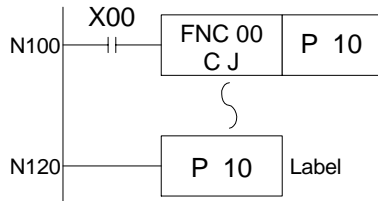

- When FNC 00 (CJ) is driven, program execution jumps to the line marked with label P10 equivalent to the pointer No. specified in this instruction.
- The part of the program skipped by the FNC 00 instruction is not executed.

<b>FNC 00</b> <b>C J N</b> CONDITIONAL JUMP	<b>Conditional jump not</b>	Applicable models	
	16-bit operation CJN 3 steps	Series name	Remarks
		● FX-10GM	
		● FX(E)-20GM	

Applicable devices and basic format

S• : Pointers P0 to P127 (in the 10GM) P0 to P255 (in the 20GM) ( Pointers used for CALL instructions should not be used for JUMP instructions.

- When the drive input condition is not satisfied, program execution jumps to the specified label.

### Example

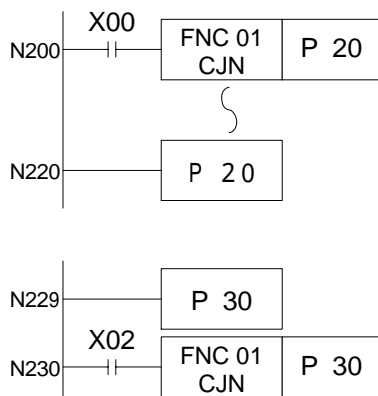

- When FNC 01 (CJN) is not driven, program execution jumps to the line marked with label P20 equivalent to the pointer No. specified in this instruction.
- If FNC 01 instruction is jumped by another jump instruction, FNC 01 is not executed.
- The part of the program skipped by the FNC 01 instruction is not executed.
- In the example shown on the left, program execution does not proceed beyond line No. N230 until X02 is turned ON. Accordingly, program execution is delayed until X02 is turned ON.



FNC 05 B R E T	<b>Bus return</b>	Applicable models	
BUS RETURN	16-bit operation    BRET 1 steps	Series name	Remarks
		● FX-10GM	
		● FX(E)-20GM	

Applicable devices and basic format	No applicable devices	<table border="1" style="margin: auto;"> <tr> <td style="text-align: center;">FNC 05 B R E T</td> </tr> </table>	FNC 05 B R E T	<ul style="list-style-type: none"> <li>When FNC 05 (BUS RETURN) instruction is executed, the instructions after that are treated as those connected to the bus.</li> </ul>
FNC 05 B R E T				

**Example**

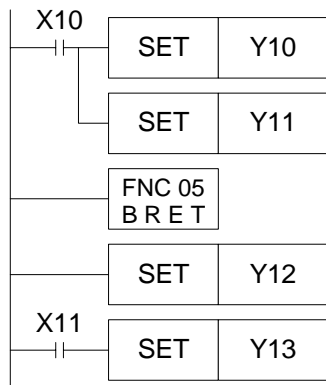

- The coils Y10 and Y11 are driven via the contact X10. However, Y12 is driven without regard to the ON/OFF status of X10.
- If the FNC 05 (BUS RETURN) instruction is not included in the program, Y12 is also driven by X10.
- Y13 is driven when X11 is ON.

**Other instructions that cause a return to the bus**

When either of the following instructions is used in the program, bus line return is automatically performed even if the BRET instruction is not included in the program.

Positioning control instructions (cod instructions).

M code instructions in AFTER mode.

Application instructions such as FNC 03 (RET), FNC 04 (JMP), FNC 08 (RPT), FNC 09 (RPE), etc. that are not used with drive contacts.

When FNC 00 (CJ) or FNC 01 (CJN) instruction is executed.





<b>FNC 12</b> <b>MOV</b> MOVE	<b>Transfer</b>	Applicable models
	16-bit operation MOV 5 steps	32-bit operation <b>D</b> MOV 8 steps
Applicable devices and basic format		
	<ul style="list-style-type: none"> <li>When the drive input is ON, the data of (S) is transmitted to (D) without any change. When the drive input is OFF, the contents of (D) remain unchanged.</li> </ul>	

Example

X22	<b>FNC 12</b> <b>MOV</b> K100    D 11	<ul style="list-style-type: none"> <li>When the X22 is turned ON, K100 is transmitted to the D11.</li> </ul>
-----	--	--

<b>FNC 13</b> <b>MMOV</b> MAGNIFY MOVE	<b>Magnification transfer</b>	Applicable models
	16-bit operation MMOV 5 steps	32-bit operation <b>D</b> MMOV 8 steps
Applicable devices and basic format		
	<ul style="list-style-type: none"> <li>The data in the 16-bit device (S) is transmitted to the 32-bit device (D) with the specified sign bit repeatedly duplicated.</li> </ul>	

Example

X23	<b>FNC 13</b> <b>MMOV</b> D 4    D 6	<ul style="list-style-type: none"> <li>When X23 is turned ON, the data in D4 is transmitted to D6 and D7.</li> </ul>
-----	---	--

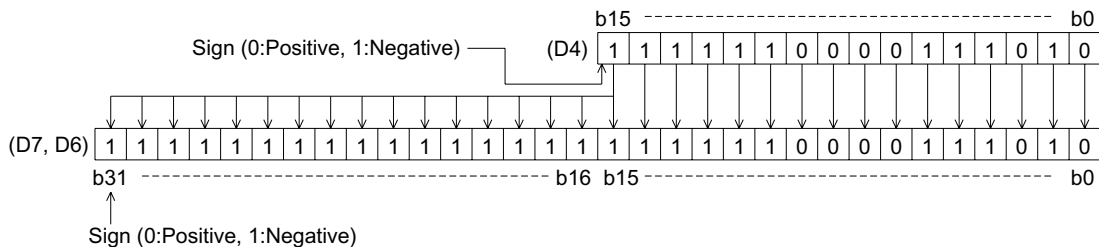

- In the example above, b15 of D4 is transmitted to b15 to b31 of (D7/D6), and the data of (D7/D6) becomes a negative value (the same as D4).

<b>FNC 14</b> <b>RMOV</b> REDUCE MOVE	<b>Reduction transfer</b> 16-bit operation RMOV 5 steps	Applicable models <table border="1" style="width: 100%; border-collapse: collapse;"> <thead> <tr> <th style="width: 50%;">Series name</th> <th style="width: 50%;">Remarks</th> </tr> </thead> <tbody> <tr> <td style="text-align: center;">● FX-10GM</td> <td></td> </tr> <tr> <td style="text-align: center;">● FX(E)-20GM</td> <td></td> </tr> </tbody> </table>	Series name	Remarks	● FX-10GM		● FX(E)-20GM	
Series name	Remarks							
● FX-10GM								
● FX(E)-20GM								

  

Applicable devices and basic format	<div style="display: flex; align-items: center;"> <div style="margin-right: 20px;">                 Word devices  <table border="1" style="border-collapse: collapse; text-align: center;"> <tr> <td style="width: 15%;">K,H</td> <td style="width: 15%;">KnX</td> <td style="width: 15%;">KnY</td> <td style="width: 15%;">KnM</td> <td style="width: 15%;">D</td> <td style="width: 15%;">V,Z</td> </tr> </table> </div> <div style="margin-right: 20px;">                 Drive input  <table border="1" style="border-collapse: collapse; text-align: center;"> <tr> <td style="width: 15%;">FNC 14</td> <td style="width: 15%;">RMOV</td> <td style="width: 15%;">S</td> <td style="width: 15%;">D</td> </tr> </table> </div> <div> <ul style="list-style-type: none"> <li>• The data in the 32-bit device (S) is transmitted to the 16-bit device (D) retaining the sign bit.</li> </ul> </div> </div> <div style="margin-top: 10px; text-align: center;"> <table style="margin: auto;"> <tr> <td style="text-align: center;">Transfer source 32-bit</td> <td style="text-align: center;">Transfer destination 16-bit</td> </tr> </table> </div>	K,H	KnX	KnY	KnM	D	V,Z	FNC 14	RMOV	S	D	Transfer source 32-bit	Transfer destination 16-bit
K,H	KnX	KnY	KnM	D	V,Z								
FNC 14	RMOV	S	D										
Transfer source 32-bit	Transfer destination 16-bit												

**Example**

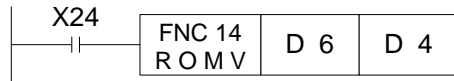

- When X24 is turned ON, the contents of D6 and D7 are transmitted to D4.

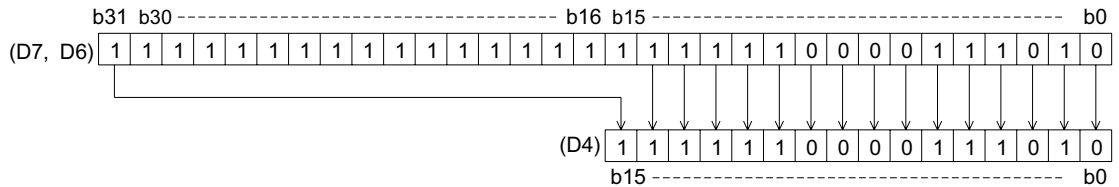

When X24 is turned ON, the most significant bit in (S) is transmitted to most significant bit in (D). Other bits are transmitted in turn from the least significant bit. b15 to b30 are ignored and not transmitted.

<b>FNC 18</b> <b>B C D</b>	<b>BCD conversion</b>	Applicable models						
BINARY CODED TO DECIMAL	<div style="display: flex; justify-content: space-between;"> <div style="border: 1px dashed black; padding: 2px; font-size: x-small;">16-bit operation BCD 5 steps</div> <div style="border: 1px dashed black; padding: 2px; font-size: x-small;">32-bit operation <input checked="" type="checkbox"/>BCD 8 steps</div> </div>	<table border="1" style="width: 100%; border-collapse: collapse; font-size: x-small;"> <thead> <tr> <th style="width: 50%;">Series name</th> <th style="width: 50%;">Remarks</th> </tr> </thead> <tbody> <tr> <td><input type="checkbox"/> FX-10GM</td> <td></td> </tr> <tr> <td><input type="checkbox"/> FX(E)-20GM</td> <td></td> </tr> </tbody> </table>	Series name	Remarks	<input type="checkbox"/> FX-10GM		<input type="checkbox"/> FX(E)-20GM	
Series name	Remarks							
<input type="checkbox"/> FX-10GM								
<input type="checkbox"/> FX(E)-20GM								

  

Applicable devices and basic format

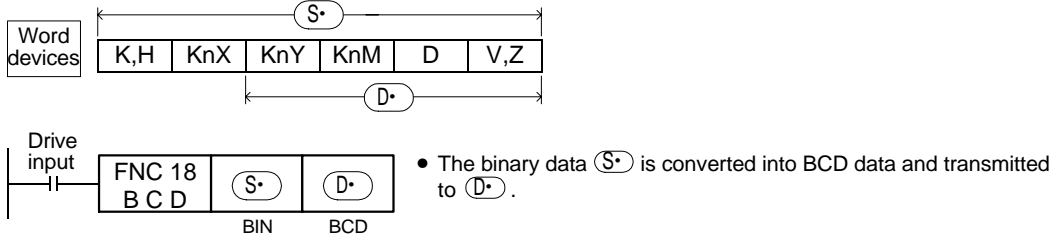

• The binary data (S) is converted into BCD data and transmitted to (D).

**Example**

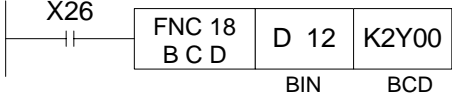

- When X26 is turned ON, D12 (binary data) is converted into BCD and transmitted to Y0 to Y7.

- The BCD instruction is not executed if the BCD conversion result is outside 0 to 9,999. The BCD instruction is not executed if the BCD conversion result is outside 0 to 99,999,99.
- The BCD instruction is used to convert binary data in the positioning unit into BCD data (for 7-segment display, etc.) to be output to external equipment.

<b>FNC 19</b> <b>B C D</b>	<b>BIN conversion</b>	Applicable models						
BINARY	<div style="display: flex; justify-content: space-between;"> <div style="border: 1px dashed black; padding: 2px; font-size: x-small;">16-bit operation BIN 5 steps</div> <div style="border: 1px dashed black; padding: 2px; font-size: x-small;">32-bit operation <input checked="" type="checkbox"/>BIN 8 steps</div> </div>	<table border="1" style="width: 100%; border-collapse: collapse; font-size: x-small;"> <thead> <tr> <th style="width: 50%;">Series name</th> <th style="width: 50%;">Remarks</th> </tr> </thead> <tbody> <tr> <td><input type="checkbox"/> FX-10GM</td> <td></td> </tr> <tr> <td><input type="checkbox"/> FX(E)-20GM</td> <td></td> </tr> </tbody> </table>	Series name	Remarks	<input type="checkbox"/> FX-10GM		<input type="checkbox"/> FX(E)-20GM	
Series name	Remarks							
<input type="checkbox"/> FX-10GM								
<input type="checkbox"/> FX(E)-20GM								

  

Applicable devices and basic format

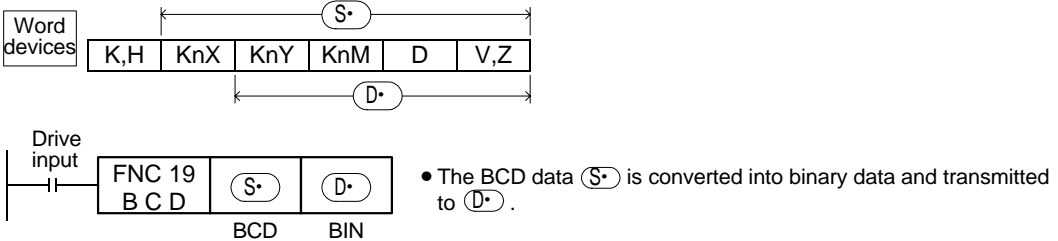

• The BCD data (S) is converted into binary data and transmitted to (D).

**Example**

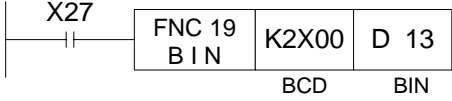

- When X27 is turned ON, BCD data in X00 to X07 is converted into binary and transmitted to D13.

- The BIN instruction is used to fetch digital switch set value (BCD data) to the positioning unit. When the source data is not BCD, this instruction is not executed.



## 6.6 Arithmetic and Logical Operations

FNC 20 ADD	<b>Addition/Subtraction</b>		Applicable models								
FNC 21 SUB	16-bit operation 7 steps	ADD SUB	32-bit operation 11 steps	<input type="checkbox"/> ADD <input type="checkbox"/> SUB	<table border="1" style="width: 100%; border-collapse: collapse;"> <tr> <th style="width: 50%;">Series name</th> <th style="width: 50%;">Remarks</th> </tr> <tr> <td style="text-align: center;">● FX-10GM</td> <td></td> </tr> <tr> <td style="text-align: center;">● FX(E)-20GM</td> <td></td> </tr> </table>	Series name	Remarks	● FX-10GM		● FX(E)-20GM	
Series name	Remarks										
● FX-10GM											
● FX(E)-20GM											

Applicable devices and basic format

	Word devices	<table style="width: 100%; border-collapse: collapse;"> <tr> <td style="width: 10%;"></td> <td style="width: 10%; text-align: center;">S1•</td> <td style="width: 10%; text-align: center;">S2•</td> <td style="width: 10%;"></td> <td style="width: 10%; text-align: center;">S1•</td> <td style="width: 10%; text-align: center;">S2•</td> <td style="width: 10%;"></td> </tr> <tr> <td style="border: 1px solid black; padding: 2px;">K,H</td> <td style="border: 1px solid black; padding: 2px;">KnX</td> <td style="border: 1px solid black; padding: 2px;">KnY</td> <td style="border: 1px solid black; padding: 2px;">KnM</td> <td style="border: 1px solid black; padding: 2px;">D</td> <td style="border: 1px solid black; padding: 2px;">V,Z</td> <td style="border: 1px solid black; padding: 2px;">D•</td> </tr> </table>		S1•	S2•		S1•	S2•		K,H	KnX	KnY	KnM	D	V,Z	D•	<b>Flags:</b> Described below. <table border="1" style="width: 100%; border-collapse: collapse; margin-top: 5px;"> <thead> <tr> <th style="width: 10%;"></th> <th style="width: 30%;">X axis, simultaneous 2-axis</th> <th style="width: 30%;">Y axis (Not 10GM)</th> <th style="width: 30%;">Subtask</th> </tr> </thead> <tbody> <tr> <td style="text-align: center;">Zero</td> <td style="text-align: center;">M9061</td> <td style="text-align: center;">M9093</td> <td style="text-align: center;">M9133</td> </tr> <tr> <td style="text-align: center;">Borrow</td> <td style="text-align: center;">M9062</td> <td style="text-align: center;">M9094</td> <td style="text-align: center;">M9134</td> </tr> <tr> <td style="text-align: center;">Carry</td> <td style="text-align: center;">M9063</td> <td style="text-align: center;">M9095</td> <td style="text-align: center;">M9135</td> </tr> </tbody> </table>		X axis, simultaneous 2-axis	Y axis (Not 10GM)	Subtask	Zero	M9061	M9093	M9133	Borrow	M9062	M9094	M9134	Carry	M9063	M9095	M9135
	S1•	S2•		S1•	S2•																												
K,H	KnX	KnY	KnM	D	V,Z	D•																											
	X axis, simultaneous 2-axis	Y axis (Not 10GM)	Subtask																														
Zero	M9061	M9093	M9133																														
Borrow	M9062	M9094	M9134																														
Carry	M9063	M9095	M9135																														

Drive input	FNC 20 ADD	S1•	S2•	D•	
	Augend	Addend	Result		

- $S1• + S2• = D•$   
A negative value is treated as two's complement.

Drive input	FNC 21 SUB	S1•	S2•	D•	
	Minuend	Subtrahend	Result		

- $S1• - S2• = D•$   
A negative value is treated as two's complement.

### Example

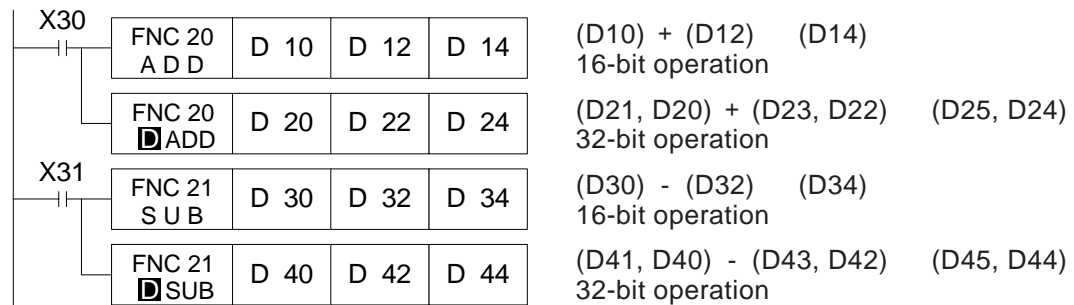

### Flag operations

As shown in the table above, selection of the special auxiliary relays used as flags varies depending on program type (for the X axis, for simultaneous 2-axis, for the Y axis and for subtasks).

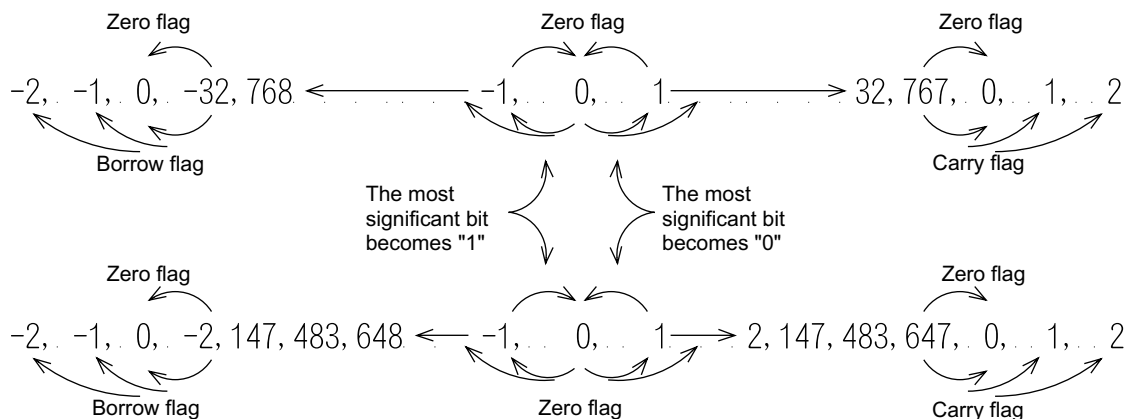

<b>FNC 22</b> <b>M U L</b>	<b>Multiplication</b>	Applicable models						
MULTIPLICATION	16-bit operation MUL 7 steps	32-bit operation <input checked="" type="checkbox"/> MUL 11 steps						
Applicable devices and basic format		<table border="1" style="width: 100%; border-collapse: collapse;"> <thead> <tr> <th style="width: 50%;">Series name</th> <th style="width: 50%;">Remarks</th> </tr> </thead> <tbody> <tr> <td style="text-align: center;"><input type="checkbox"/> FX-10GM</td> <td></td> </tr> <tr> <td style="text-align: center;"><input type="checkbox"/> FX(E)-20GM</td> <td></td> </tr> </tbody> </table>	Series name	Remarks	<input type="checkbox"/> FX-10GM		<input type="checkbox"/> FX(E)-20GM	
Series name	Remarks							
<input type="checkbox"/> FX-10GM								
<input type="checkbox"/> FX(E)-20GM								

$S1 \times S2 = D$   
 Pay careful attention to the operation result (Refer to the example below.)

**Example**

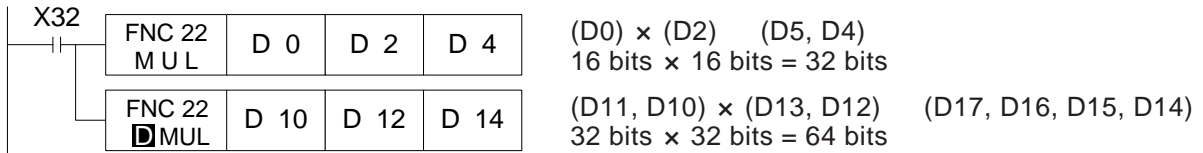

When the data of either source is a negative value, the product is also a negative value. In a 32-bit operation, the product is 64 bits. Because 64-bit data cannot be monitored, numerics handled in multiplication must be such that the multiplication product is 32 bits or less.

<b>FNC 23</b> <b>D I V</b>	<b>Division</b>	Applicable models						
DIVISION	16-bit operation DIV 7 steps	32-bit operation <input checked="" type="checkbox"/> DIV 11 steps						
Applicable devices and basic format		<table border="1" style="width: 100%; border-collapse: collapse;"> <thead> <tr> <th style="width: 50%;">Series name</th> <th style="width: 50%;">Remarks</th> </tr> </thead> <tbody> <tr> <td style="text-align: center;"><input type="checkbox"/> FX-10GM</td> <td></td> </tr> <tr> <td style="text-align: center;"><input type="checkbox"/> FX(E)-20GM</td> <td></td> </tr> </tbody> </table>	Series name	Remarks	<input type="checkbox"/> FX-10GM		<input type="checkbox"/> FX(E)-20GM	
Series name	Remarks							
<input type="checkbox"/> FX-10GM								
<input type="checkbox"/> FX(E)-20GM								

$S1 \div S2 = D \dots D + 1$   
 Pay careful attention to the operation result (Refer to the example below.)

**Example**

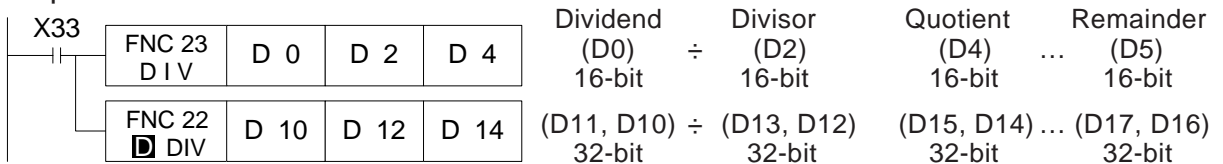

This instruction is not executed when the divisor is "0". The quotient becomes a negative value when either the dividend or the divisor is a negative value. The remainder becomes a negative value when the dividend is a negative value.

FNC 24 I N C	<b>Increment/Decrement</b>		Applicable models						
FNC 25 D E C	16-bit operation    I N C 3 steps                    D E C	32-bit operation <input checked="" type="checkbox"/> I N C 5 steps <input checked="" type="checkbox"/> D E C	<table border="1" style="width: 100%; border-collapse: collapse;"> <thead> <tr> <th style="width: 50%;">Series name</th> <th style="width: 50%;">Remarks</th> </tr> </thead> <tbody> <tr> <td style="text-align: center;"><input checked="" type="checkbox"/> FX-10GM</td> <td></td> </tr> <tr> <td style="text-align: center;"><input checked="" type="checkbox"/> FX(E)-20GM</td> <td></td> </tr> </tbody> </table>	Series name	Remarks	<input checked="" type="checkbox"/> FX-10GM		<input checked="" type="checkbox"/> FX(E)-20GM	
Series name	Remarks								
<input checked="" type="checkbox"/> FX-10GM									
<input checked="" type="checkbox"/> FX(E)-20GM									

**Applicable devices and basic format**

Word devices: K, H | KnX | KnY | KnM | D | V, Z

← D →

Drive input: FNC 24 I N C (D) +1

- Every time the instruction is executed, "1" is added to the value of (D).

Drive input: FNC 25 D E C (D) -1

- Every time the instruction is executed, "1" is subtracted from the value of (D).

Change to (D) in a 16-bit operation +1 (INC)

-32,768 — 0 — +32,767

-1 (DEC)

Change to (D) in a 32-bit operation +1 (INC)

-2,147,483,648 — 0 — +2,147,483,647

-1 (DEC)

\* The ring operations shown above are performed, but the flags do not operate.

FNC 26 W A N D	<b>Logical product (AND)/Logical sum (OR)/Logical equivalence (XOR)</b>		Applicable models						
FNC 27 W O R	16-bit operation	32-bit operation	<table border="1" style="width: 100%; border-collapse: collapse;"> <thead> <tr> <th style="width: 50%;">Series name</th> <th style="width: 50%;">Remarks</th> </tr> </thead> <tbody> <tr> <td style="text-align: center;"><input checked="" type="checkbox"/> FX-10GM</td> <td></td> </tr> <tr> <td style="text-align: center;"><input checked="" type="checkbox"/> FX(E)-20GM</td> <td></td> </tr> </tbody> </table>	Series name	Remarks	<input checked="" type="checkbox"/> FX-10GM		<input checked="" type="checkbox"/> FX(E)-20GM	
Series name	Remarks								
<input checked="" type="checkbox"/> FX-10GM									
<input checked="" type="checkbox"/> FX(E)-20GM									
FNC 28 W X O R	7 steps	11 steps							

**Applicable devices and basic format**

Word devices: K, H | KnX | KnY | KnM | D | V, Z

← S1 S2 →

← D →

Drive input: FNC26 W A N D (S1) (S2) (D)

$S1 \wedge S2 \rightarrow D$

- Logical multiplication operation is executed between each pair of bits.  
 $1 \wedge 1=1, 1 \wedge 0=0, 0 \wedge 1=0, 0 \wedge 0=0$   
 Convenient to set a certain bit to "0".

Drive input: FNC 27 W O R (S1) (S2) (D)

$S1 \vee S2 \rightarrow D$

- Logical addition operation is executed between each pair of bits.  
 $1 \vee 1=1, 1 \vee 0=1, 0 \vee 1=1, 0 \vee 0=0$   
 Convenient to set a certain bit to "1".

Drive input: FNC 28 W X O R (S1) (S2) (D)

$S1 \nabla S2 \rightarrow D$

- Logical equivalence operation is executed between each pair of bits.  
 $1 \nabla 1=0, 1 \nabla 0=1, 0 \nabla 1=1, 0 \nabla 0=0$   
 Convenient to compare between certain bits to evaluate equivalence.





**Reading a positive/negative numeric** (Not available in the FX-10GM.)

When K17 to K24 are used to specify the number of digits, negative numeric values can also be read.

**Example**

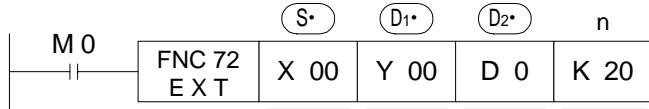

This instruction performs time-sharing reading of the data from the digital switches.

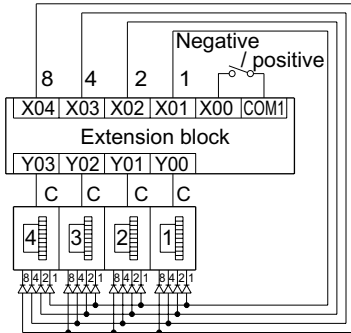

**Head input No. (Occupies 5 input points.)**

The connections in this example are as follows.

X00: Positive/negative specification input.

When the X00 is ON: Negative value.

When the X00 is OFF: Positive value

X01: Terminal 1 of DSW

X02: Terminal 2 of DSW

X03: Terminal 4 of DSW

X04: Terminal 8 of DSW

Each digit of DSW is connected via a diode (50 V, 100 mA).

**Head output No. for time-sharing operation (Occupies 4 output points.)**

Same as the description on the previous page.

**Data storage destination**

Same as the description on the previous page.

**Number of digits**

K17 (H11) to K24 (H18) are used in accordance with the number of digits from 1 to 8 (16 is added to the number of digits to determine the "K" value.).

A 32-bit instruction must be used when the number of digits is 5 to 8.

**Remarks**

The I/Os shown in the table below are required for the EXT instruction in accordance with the number of digits to be read.

Number of digits to be read	Reading a positive value.			Reading a negative value (not 10GM).			Number of data registers occupied
	Number of inputs	Number of outputs	n set value	Number of inputs	Number of outputs	n set value	
1	4	1	K1	5	1	K17	1
2		2	K2		2	K18	
3		3	K3		3	K19	
4		4	K4		4	K20	
5		5	K5		5	K21	2
6		6	K6		6	K22	
7		7	K7		7	K23	
8		8	K8		8	K24	

- To read DSW settings, the digit-switching time (Initial value: 20 msec) set to PARA. 33 is required. When a DSW is connected to the positioning unit, PARA. 33 can be set to approximately 7 msec. If programmable controller outputs are used instead of a DSW take the digit-switching time of the programmable controller into consideration and set a sufficient length of time.

<b>FNC 74</b> <b>SEGL</b>  SEVEN SEGMENT WITH LATCH	<b>7-segment time sharing display</b>  16-bit operation SEGL      32-bit operation <b>D</b> SEGL 9 steps                              14 steps	Applicable models <table border="1" style="width: 100%; border-collapse: collapse;"> <thead> <tr> <th style="width: 70%;">Series name</th> <th>Remarks</th> </tr> </thead> <tbody> <tr> <td>● FX-10GM</td> <td></td> </tr> <tr> <td>● FX(E)-20GM</td> <td></td> </tr> </tbody> </table>	Series name	Remarks	● FX-10GM		● FX(E)-20GM	
Series name	Remarks							
● FX-10GM								
● FX(E)-20GM								
Applicable devices and basic format	<table style="width: 100%;"> <tr> <td style="width: 30%;">                     Word devices                      K,H   KnX   KnY   KnM   D   V,Z                      └─┬─┘   └─┬─┘                      n1 n2                              S                 </td> <td style="width: 30%;">                     Bit devices                      X   Y   M                      └─┬─┘                      D                 </td> <td style="width: 40%; vertical-align: top;"> <ul style="list-style-type: none"> <li>The 7-segment display with a latch function is controlled using the time-sharing method.</li> </ul> </td> </tr> <tr> <td>                     Drive input                      FNC 74 SEGL   S   D   n1   n2                      └─┬─┘   └─┬─┘   └─┬─┘   └─┬─┘                      Display data   Head output No.   Number of digits   Logic                 </td> <td colspan="2"></td> </tr> </table>		Word devices K,H   KnX   KnY   KnM   D   V,Z └─┬─┘   └─┬─┘ n1 n2                              S	Bit devices X   Y   M └─┬─┘ D	<ul style="list-style-type: none"> <li>The 7-segment display with a latch function is controlled using the time-sharing method.</li> </ul>	Drive input FNC 74 SEGL   S   D   n1   n2 └─┬─┘   └─┬─┘   └─┬─┘   └─┬─┘ Display data   Head output No.   Number of digits   Logic		
Word devices K,H   KnX   KnY   KnM   D   V,Z └─┬─┘   └─┬─┘ n1 n2                              S	Bit devices X   Y   M └─┬─┘ D	<ul style="list-style-type: none"> <li>The 7-segment display with a latch function is controlled using the time-sharing method.</li> </ul>						
Drive input FNC 74 SEGL   S   D   n1   n2 └─┬─┘   └─┬─┘   └─┬─┘   └─┬─┘ Display data   Head output No.   Number of digits   Logic								

**Displaying a positive numeric**

**Example**

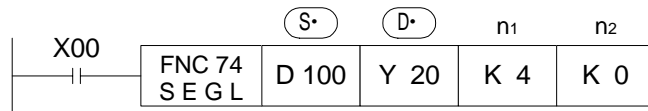

Time-sharing outputs are used for the 7-segment display with the latch function.

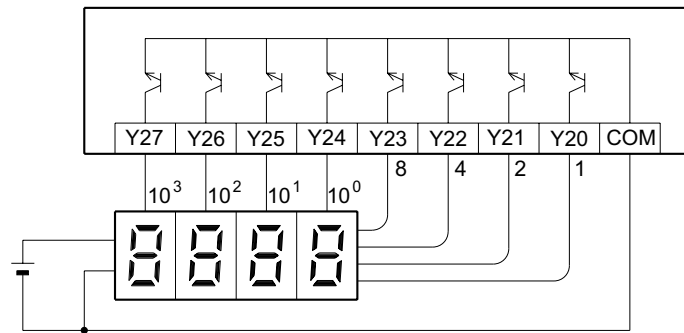

- The internal binary data is converted into BCD data, then output using the time-sharing method.
- This instruction is processed in accordance with an operation cycle. It takes 12 operation cycles to display 4 digits. This instruction can be used only twice.

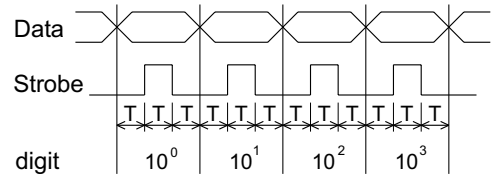

T: Subtask operation cycle

Device No. in which the data to be displayed is saved.

In this example, it is the data register D100. In the case of a 32-bit instruction, it would be D101 and D100.

Head No. for data output.

In this example, the output No. are as follows.

- Y20: To the terminal for BCD input 1
- Y21: To the terminal for BCD input 2
- Y22: To the terminal for BCD input 4
- Y23: To the terminal for BCD input 8
- Y24: To 10<sup>0</sup> digits strobe input
- Y25: To 10<sup>1</sup> digits strobe input
- Y26: To 10<sup>2</sup> digits strobe input
- Y27: To 10<sup>3</sup> digits strobe input

**Number of digits**

K1 to K4 are used with 16-bit instructions, and K5 to K8 are used with 32-bit instructions. The same number of strobe signal outputs as the specified number of digits is required.

Because in the FX-10GM, there are only up to 2 digits (K2) available for display use this instruction to display the program No. being executed, etc.

**Logic parameter**

Refer to "7-segment display logic" on the next page.

**Displaying a positive/negative numeric**

When K17 (H11) to K24 (H18) are used to specify the number of digits, negative numeric values can also be read.

**Example**

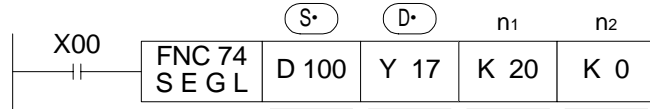

This instruction displays the 7-segment display.

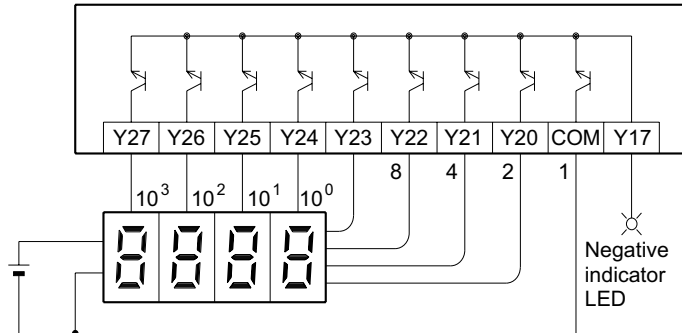

**Number of digits**

K17 (H11) to K24 (H18) are used in accordance with the number of digits from 1 to 8 (16 is added to the number of digits to determine the "K" value.).

**7-segment display logic**

Data input: "Positive logic" indicates that the input data is expressed as BCD at the high level. "Negative logic" indicates that the input data is expressed as BCD at the low level. Strobe signal: "Positive logic" indicates that data is latched and held when the signal level is high. "Negative logic" indicates that data is latched and held when the signal level is low.

**Display data device No.**

Same as on the previous page.

**Head No. for data output**

Y17: For identifying positive/negative.

When the Y17 is ON: Negative value.

When the Y17 is OFF: Positive value.

Y20: Same with the previous page.

Y27: (I/Os are octal, so Y18 and Y19 are not available.)

**Logic parameters**

Refer to the table below.

Select the following parameter setting in accordance with the 7-segment display logic.

Data input	Strobe signal	n <sub>2</sub>
Negative	Negative	K0
	Positive	K1
Positive	Negative	K2
	Positive	K3

**Remarks**

The I/Os shown in the table below are required for the SEGL instruction in accordance with the number of digits to be displayed.

Number of digits to be read	Reading a positive value		Reading a negative value		Number of data registers occupied
	Number of outputs	"n1" set value	Number of outputs	"n1" set value	
1	1	K1	1	K17	1
2	2	K2	2	K18	
3	3	K3	3	K19	
4	4	K4	4	K20	
5	5	K5	5	K21	2
6	6	K6	6	K22	
7	7	K7	7	K23	
8	8	K8	8	K24	

↑ Set values up to K2 are available in the 10GM.

↑ K17 only is available in the 10GM.



## 6.8 Other Instructions

FNC 90 OUT	<b>Output</b>	Applicable models	
OUT	16-bit operation    OUT 3 steps	Series name	Remarks
		● FX-10GM	
		● FX(E)-20GM	

Bit devices

X	Y	M
<div style="border: 1px solid black; border-radius: 50%; width: 20px; height: 20px; margin: 0 auto; display: flex; align-items: center; justify-content: center;">D•</div>		

Drive input

FNC 90  
OUT

- This is an ordinary coil instruction. When this instruction is driven with the contact turned ON, the output is turned ON. When this instruction is driven with the contact turned OFF, the output is turned OFF.

### Example

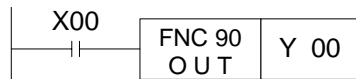

- Y00 is output if X00 is ON when the program shown on the left is executed. Y00 is turned OFF when X00 is OFF.
- If there is no contact instruction for drive input before the FNC 90 (OUT) instruction (that is, when FNC 90 instruction is directly given from the bus), Y00 continues to be ON.

FNC 92 X A B	<b>Absolute position detection</b>	Applicable models									
FNC 93 Y A B	16-bit operation    XAB 1 steps                YAB	<table border="1" style="width: 100%; border-collapse: collapse;"> <thead> <tr> <th style="width: 10%;"></th> <th style="width: 60%;">Series name</th> <th style="width: 30%;">Remarks</th> </tr> </thead> <tbody> <tr> <td style="text-align: center;">●</td> <td>FX-10GM</td> <td></td> </tr> <tr> <td style="text-align: center;">●</td> <td>FX(E)-20GM</td> <td></td> </tr> </tbody> </table>		Series name	Remarks	●	FX-10GM		●	FX(E)-20GM	
	Series name	Remarks									
●	FX-10GM										
●	FX(E)-20GM										

Applicable devices: Y, M (specified by PARA.50 and PARA.51)

Applicable devices and basic format

Drive input FNC 92 X A B

- X axis absolute position detection.
- ABS sensing is automatically performed when the power is turned ON. However, this instruction allows it to be performed at any other time. Each time this instruction is executed, the present value is read from the servo amplifier and saved in the present value register. This instruction is only available when ABS sensing is enabled by PARAs 50 to 52.

Drive input FNC 93 Y A B

- Y axis absolute position detection. (Not available in the FX-10GM.)

**Example**

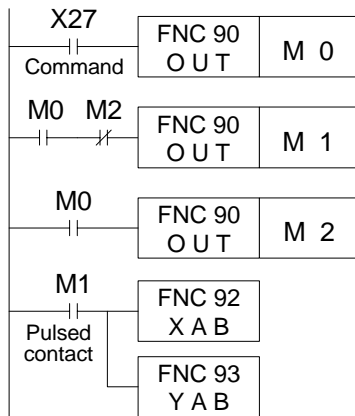

- To allow repeated execution and yet execute this instruction only once, a pulsed signal is required. An example of a pulsed signal is shown below. When the command input is X, replace it with an M. This establishes a direct method for controlling the input and output when the instruction is executed.
- This instruction is usually used in the subtask program O100.

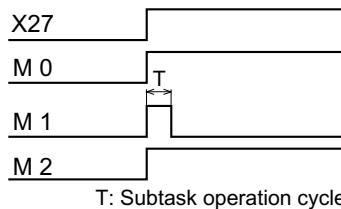

## 7. Communication with Programmable Controller

When the FX-10GM/FX-20GM positioning unit is connected to the FX/FX<sub>2c</sub> Series programmable controller, positioning data such as the travel, the operation speed, etc., can be set and the present position can be monitored. This section explains the communication with the programmable controller to perform these operations.

### 7.1 Outline

Communication with the programmable controller is performed using the FROM/TO instruction of the programmable controller via buffer memories (BFM) inside the positioning unit.

- The schematic diagram below shows the communication between the programmable controller and the positioning unit. (For system configuration, refer to Section 1.)

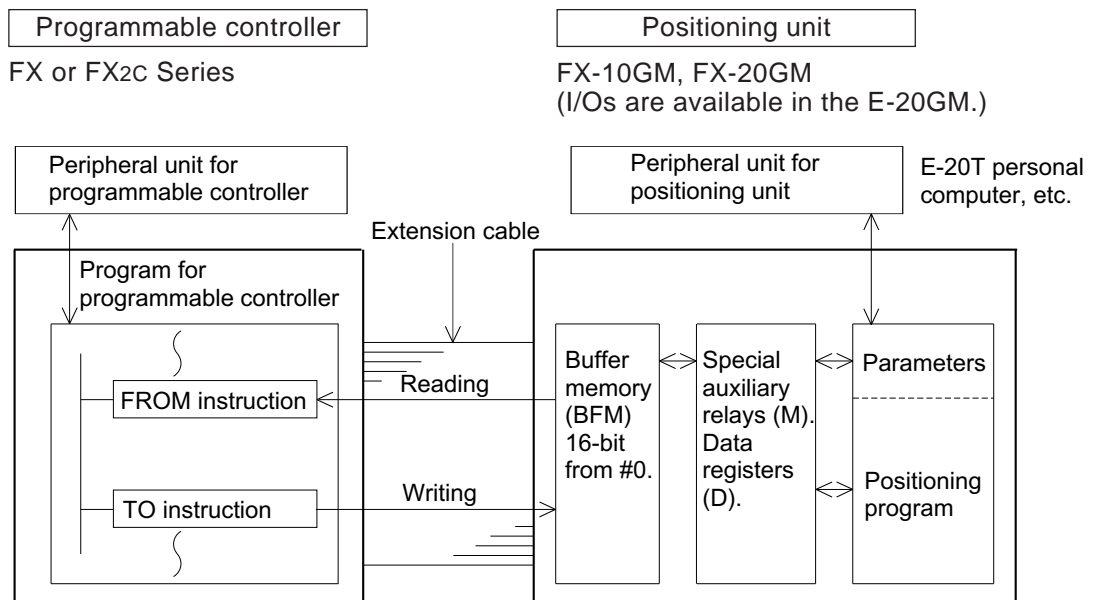

FROM instruction: Reads the contents of the BFM to the programmable controller.

TO instruction: Writes the contents of the programmable controller to the BFM.

- Between the programmable controller and the buffer memories in the positioning unit, communication is performed when the FROM or TO instruction in the sequence program is executed. At this time, the positioning unit may be in the MANU or AUTO mode.
- The buffer memories interlock with the special Ms and the special Ds in the positioning unit. When the contents of the buffer memories change, the contents of the special Ms and the special Ds also change. The positioning unit automatically performs communication between them.

## 7.2 Buffer Memories

### 7.2.1 Configuration of the buffer memories

The buffer memories correspond to the device memories such as parameters, various special Ms and various special Ds as shown in the configuration diagram on the previous page. (For details, refer to the next page.)

#### Configuration of the buffer memories

- The buffer memory No. is indicated as "#". One point consists of 16-bit data.
- Bit devices such as auxiliary relays, I/O relays, etc. in the positioning unit and word devices such as data registers, parameters, etc. are assigned to 16-bit data in the buffer memories.

#### Bit devices

- Each bit of the buffer memories to which bit devices are assigned operates differently.

#### Example

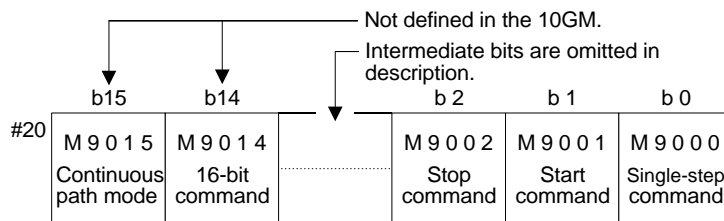

The figure above shows the buffer memory #20. The special auxiliary relays M9000 to M9015 are assigned to #20. For example, M9001 (X axis start command) is assigned to Bit 1 of #20. When a sequence program is created so that this bit is turned ON by the TO instruction (writing to the buffer memories), the start command is given.

#### Word devices

- The buffer memory to which a word device is assigned expresses a single value in 16 bits or 32 bits.

#### Example

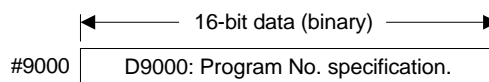

The figure above shows the buffer memory #9000 to which D9000 is assigned. For example, when data is written to #9000 using the TO instruction, the program No. can be specified. Word devices are easy to follow because the buffer memory No. is equivalent to the device No. of the special Ds.

**D** is added to the FROM/TO instruction when 32-bit data, such as the present position, is included in a program. (By turning ON M9014, the 32-bit general purpose registers and file registers can be handled as 16-bit data.) . . . Refer to the next page.

### 7.2.2 FROM/TO instructions

The buffer memories are classified into independent 16-bit type **S** and consecutive 32-bit type **D** as shown in the list on the next page.

#### M9014

- By turning ON special auxiliary relay M9014 (BFM #20, b14), 32-bit buffer memories are treated as separate 16-bit types. This allows the TO instruction (without **D**) to send 16-bit data to each BFM separately. However, this operation does not apply to the special data registers D9000 onwards.

#### Example

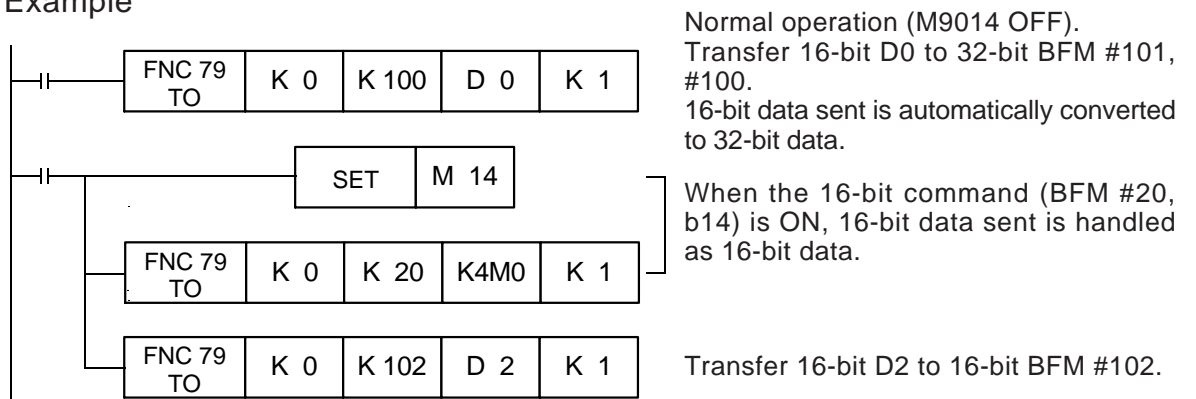

### 7.2.3 Assignment of buffer memories

Various devices and parameters inside the positioning unit are assigned as shown in the table below; the same data is saved in buffer memory and the corresponding devices.

For details of special Ms, special Ds and parameters, refer to Section 4. In the FX-10GM, the buffer memories for unavailable devices such as special Ms, special Ds and parameters for the Y axis are not used.

**Table:7.1 Assignment of buffer memories**

BFM No.	Corresponding devices		BFM No.	Corresponding devices		
# 0	D9000	These correspond to the special data registers BFM #9000 to #9019. <b>S</b> or <b>D</b> .	#101, #100	D101, D100	General purpose registers. File registers <b>D</b> .	
# 1	D9001		#103, #102	D103, D102		
}	}		}	}		
# 19	D9019		#6999, #6998	D6999, D6998		
# 20	M9015 to M9000	Special auxiliary relays <b>S</b>	#7000	Not defined.		
# 21	M9031 to M9016		}	#8999		
# 22	M9047 to M9032			#9000	D9000	These correspond to the special data registers BFM #0 to #19. <b>S</b> or <b>D</b> .
# 23	M9063 to M9048			#9001	D9001	
# 24	M9079 to M9064			}	}	
# 25	M9095 to M9080			#9019	D9019	These double correspond to the special data registers BFM #0 to #19. <b>S</b> or <b>D</b> .
# 26	M9111 to M9096			#9020	D9020	
# 27	M9127 to M9112			#9021	D9021	
# 28	M9143 to M9128			}	}	
# 29	M9159 to M9144			#9199	D9199	X axis parameters <b>D</b> .
# 30	M9175 to M9160			#9200	D9200	
# 31	Not defined.			#9201	D9201	
# 32	X07 to X00	Input relays <b>S</b>	}	}	Y axis parameters <b>D</b> .	
# 33	Not defined.			#9339		D9339
# 34	"			#9400		D9400
# 35	"			#9401	D9401	
}	}			}	}	
# 47	X377 to X360	Output relays <b>S</b>	#9599	D9599		
# 48	Y07 to Y00					
# 49	Not defined.					
# 50	"					
# 51	"					
}	}	Auxiliary relays <b>S</b>				
# 63	Not defined.					
# 64	M15 to M0					
# 65	M31 to M16					
}	}					
# 95	M511 to M496					
# 65	Not defined					
}						
# 99						

**Remarks**

- The FX Series (Ver. 3.07 manufactured from November, 1994 or later) and the FX2c Series programmable controllers are equipped with an increased number of transfer points for the FROM/TO instructions and the head BFM No. ranging from #0 to #9599 can be used freely for transfer.
- The conventional FX Series programmable controller can only use BFMs #0 to #31 for transfer.

## 7.3 Functions Enabled by the Programmable Controller

This section explains examples of the basic functions available in the programmable controller such as specification of the program No., operation commands, reading of the present value, etc.

Specifying the program No.	Section 7.3.1
Operation commands (start/stop)	Section 7.3.2
Reading the present value	Section 7.3.3
Setting the travel and speed	Section 7.3.4
Reading M codes	Section 7.3.5
Reading/Changing the parameters	Section 7.3.6

### 7.3.1 Specifying the program No.

Specify the program No. to be executed from the programmable controller.

#### Buffer memory No.

#0 or #9000: Simultaneous 2-axis,  
X-axis (10GM).

#10 or #9010: Y-axis  
Either can be set.

- When specifying a program from a programmable controller, set PARA. 30 (program No. specification method) to "3".

#### Program example

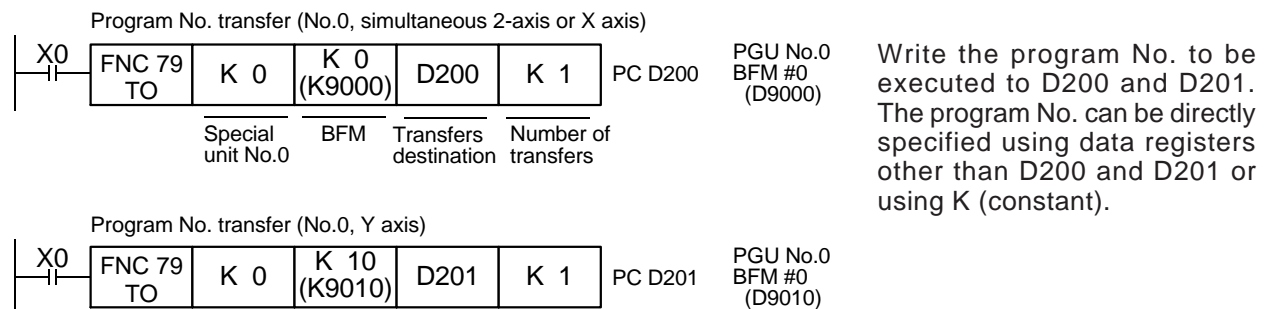

#### Data change timing

The positioning unit tries to read the program No. to be executed when the start command is given. Accordingly, the values set before the start command is given are valid regardless of the mode (MENU or AUTO). The BFM can be changed even after the start command is given. However, the new program No. set can not be executed until after the positioning program is finished at "END" and the start command is given again.

### 7.3.2 Operation commands (start/stop)

Give various operation commands from the programmable controller.

#### Buffer memory No.

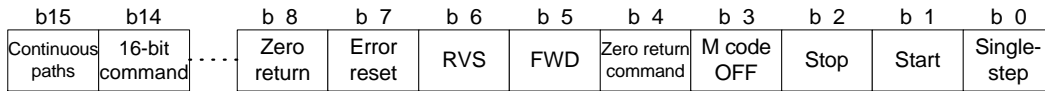

b13 to b9 of #20 and #21 are not defined. Only b0, b1, b2 and b7 of #27 (subtask) are defined. The figure above indicates the bit assignment in #20 (simultaneous 2-axis, X axis), #21 (Y axis) and #27 (subtask).

#### Program example

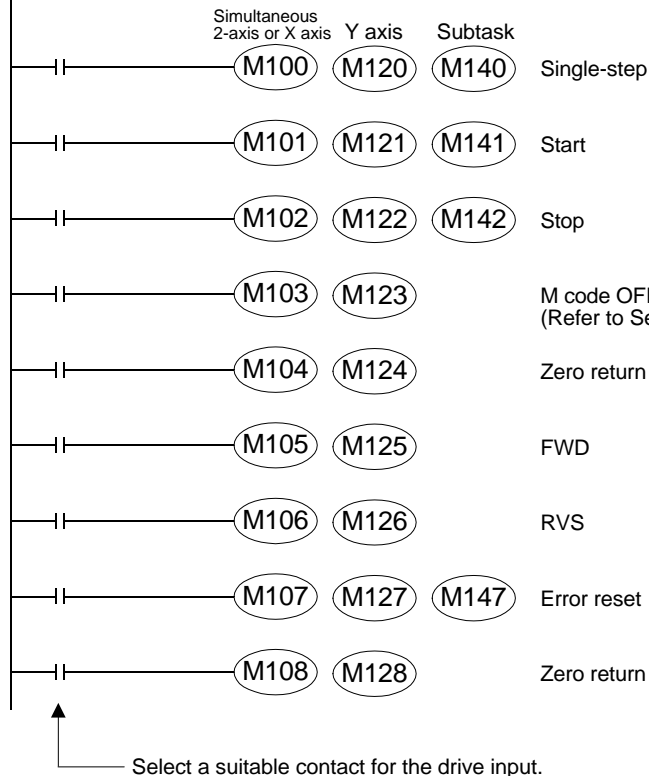
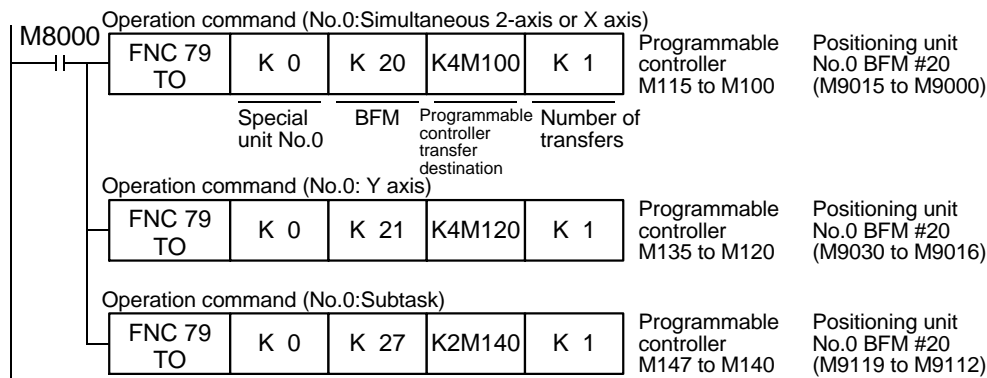

#### Input timing

The single-step, start, stop, zero return, FWD and RVS commands are processed in parallel with the external terminals of the positioning unit. Select a suitable contact for the drive input.



### 7.3.3 Reading the present value

Read the present value to the programmable controller.

#### Buffer memory No.

#5, #4 or #9005, #9004: X axis (10GM)

#15, #14 or #9015, #9014: Y axis

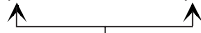

The same present position is saved.

The present position is saved as 32-bit data.

#### Program example

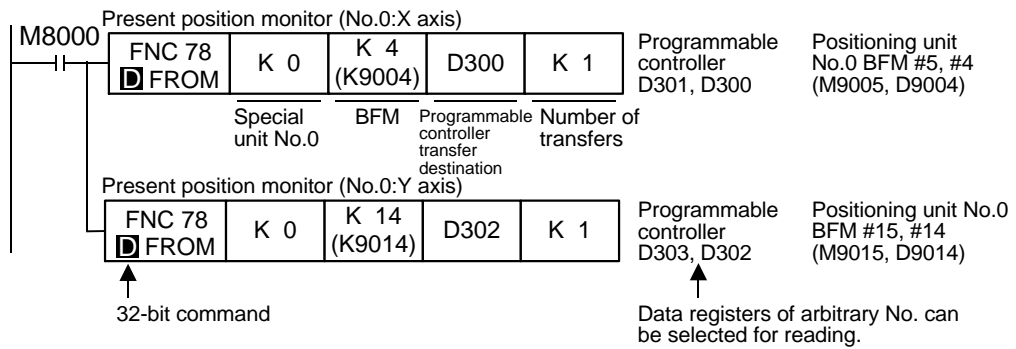

#### Data reading timing

- The present position can be read without regard to the mode (AUTO or MANU) or the status (BUSY or READY) of the positioning unit.

### 7.3.4 Setting the travel and the operation speed

Set the positioning data such as the travel and operation speed from the programmable controller.

#### Buffer memory No.

#100 ~ #6999..... FX-20GM	] These buffer memories are always handled as 32-bit data. Refer to the positioning program example shown below.
#100 ~ #1999	
#4000 ~ #5999 ) ... FX-10GM	

#### Program example

- Write the set values in the D51, the D50 and the D100 to the BFM.

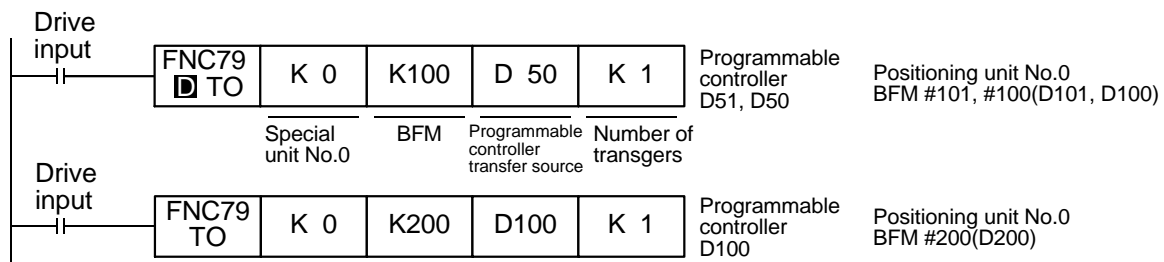

#### Positioning program example

In the positioning program, the travel, the operation speed, etc. are specified indirectly (Refer to Section 5.1.2.).

Only travel and speed are shown in this example. In addition, all the devices such as the radius, the center point, etc. that can be specified indirectly can be set from the programmable controller.

- |   |  |
|---|--|
| <pre> } cod 00 (DRV) x DD100; } SET M9014; cod 00 (DRV) x D200; SET M9014; } </pre> | <ul style="list-style-type: none"> <li>• The travel is specified by D101 and D100 (32-bit data). ("DD" specifies 32 bits.) The speed is specified as "fDDOOO".<br/>Data register No.</li> <li>• By turning ON M9014, 16-bit data can be written to the 32-bit registers using the TO instruction.</li> <li>• The travel is specified by D200 (16-bit data). The speed is specified as fDOOO.</li> <li>• After the M9014 is turned OFF, 16-bit data is written as 32-bit data.</li> </ul> |
|---|--|

#### Data change timing

- The data can be written to the buffer memories without regard to the mode (AUTO or MANU) or the status (BUSY or READY) of the positioning unit. However, because the positioning unit reads the travel and the speed set when the program is executed (when the cod instruction is executed in the example above), the set data must be written to the buffer memories before the instruction is executed. The data written while or after the instruction is executed becomes valid when the instruction is executed next time.

### 7.3.5 Reading M codes

Read out M codes to the programmable controller to drive auxiliary equipment.

#### Buffer memory No.

- The table below shows the buffer memories related to the M codes.

	Simultaneous 2-axis, X axis		Y axis	
	Buffer memory	Special M/D	Buffer memory	Special M/D
M code ON signal	#23(b3)	M9051	#25(b3)	M9083
M code OFF command	#20(b3)	M9003	#21(b3)	M9019
M code No.	#9003	D9003	#9013	D9013

\* The X axis only is available in the FX-10GM.

#### Operations of the M codes

- Each M code is driven in AFTER mode or WITH mode (Refer to Section 5.1.3.). In either mode, when the M code is driven, the M code ON signal is turned ON and the M code No. is saved in the appropriate special data register (interlocking with the buffer memory). The M code ON signal remains ON until the M code OFF signal is turned ON.
- The diagram below shows the communication between the programmable controller and the M codes.

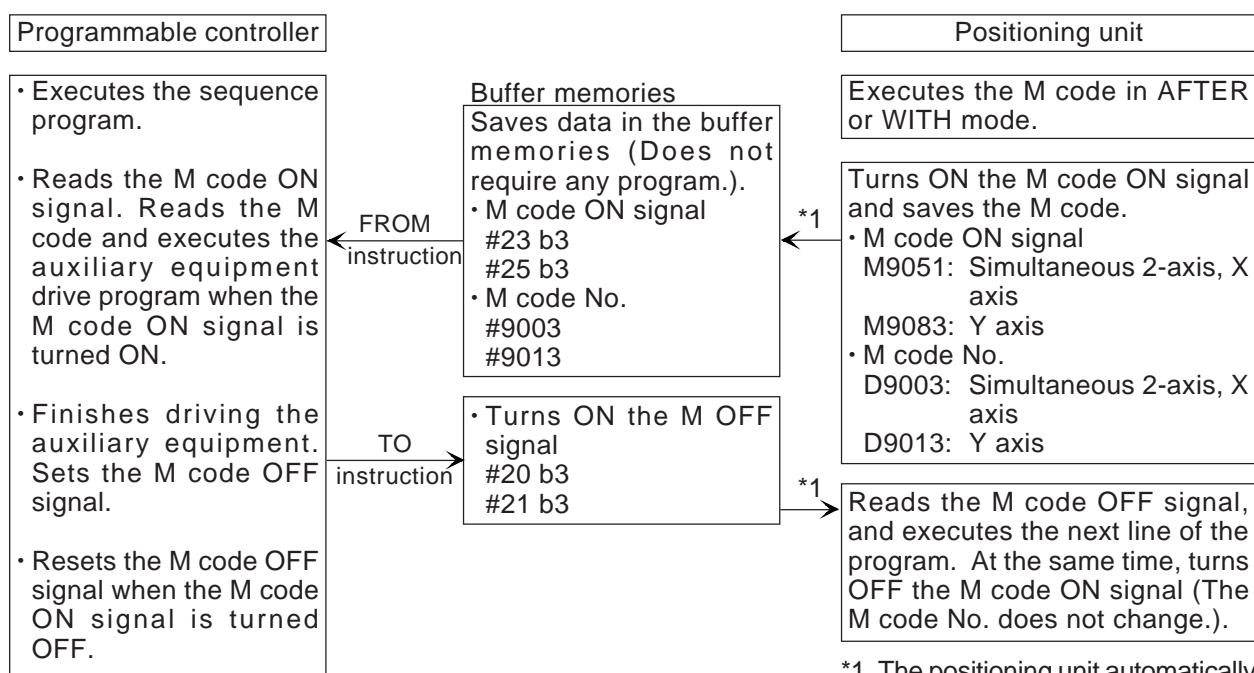

\*1 The positioning unit automatically reads from or writes to the buffer memories, the special auxiliary relays and the special data registers.

**Sequence program example** Example for the X axis

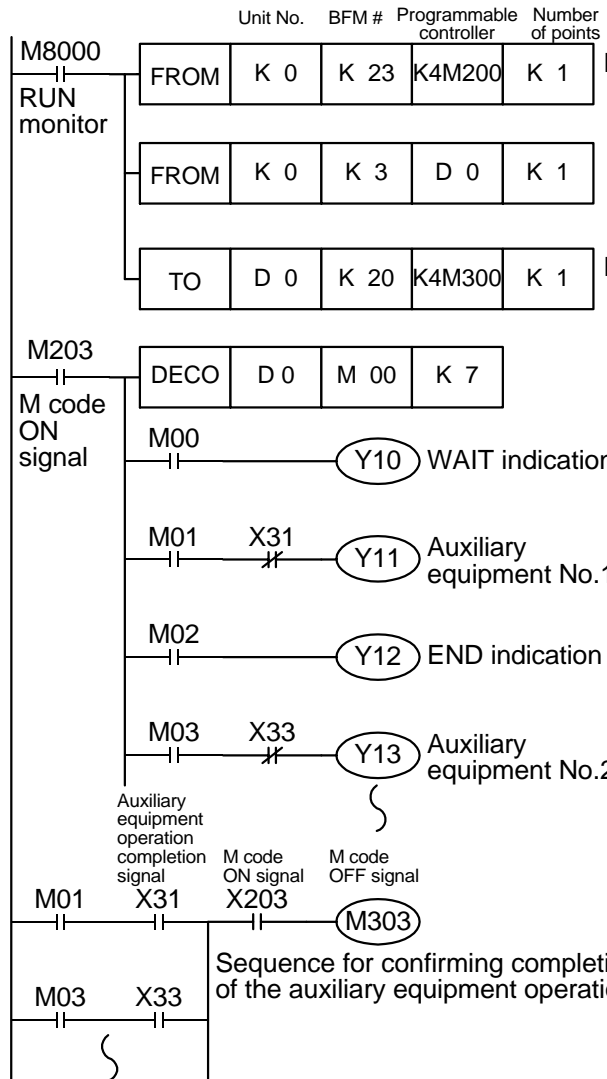

- When an M code is executed in the positioning unit, D9003 (M code No., 0 to 99) and M9051 (M code ON signal) are set and transmitted to D0 and M203 in the programmable controller.
- The programmable controller decodes them, and turns ON the specified auxiliary drive output.
- In this example, when the M code m\*\* (\*\* = 00 to 99) is executed, the auxiliary relay M\*\* is turned ON in the programmable controller.
- The programmable controller confirms the operation of the auxiliary equipment, then drives M303 (M code OFF command).
- When receiving the M code OFF command (M303 in the programmable controller M9003 in the positioning unit), the positioning unit turns OFF M9051 (M code ON signal) and proceeds to the next instruction. In the programmable controller, M203 is turned OFF.

**Positioning program example**

```

    }
cod 00 (DRV) x1000 m01;
    }
    m03;
    }
    m00; (WAIT)
  
```

- This is an M code drive command in WITH mode. The M code 01 is saved in BFM. In the example above, Y11 is driven.
- This is an M code drive command in AFTER mode. The M code 03 is saved in BFM. In the example above, Y13 is driven.
- When the WAIT instruction is executed, M code 00 is saved in BFM. In the example above, Y10 is driven.

**Data reading timing**

- The data can be read without regard to the mode (AUTO or MANU) or the status (BUSY or READY) of the positioning unit. However, it is recommended to drive the auxiliary equipment when the M code ON signal is turned ON as shown in the sequence program example above because the M code No. is only read when an M code drive instruction is executed in the positioning program.

### 7.3.6 Reading/Changing the parameters

Read or change the contents of the parameters in the positioning unit. The system parameters cannot be changed.

#### Buffer memory No.

#9200 to #9513

(X axis only in the FX-10GM. Also, some parameters are not available. For details, refer to Section 4.)

#### Sequence program example

- Change the acceleration/deceleration time of the X axis.

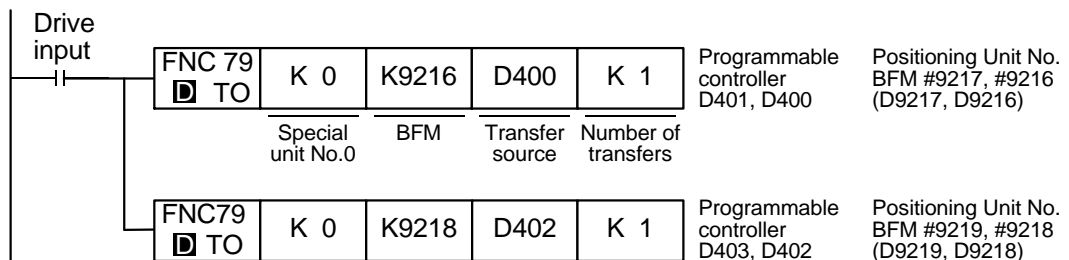

#### Data change timing

- The data can be written to the buffer memories without regard to the mode (AUTO or MANU) of the positioning unit. However, if some parameters are changed during operation, correct positioning may not be realized. Make sure to change the parameters before starting operation (that is, before entering the start input). The contents of the parameters are reset to those set by a peripheral unit when the power of the positioning unit is turned OFF.

# MEMO

## 8. CONNECTION EXAMPLES WITH MOTOR

This section shows the examples of connection with the drive unit of a stepping motor or servo motor.

When connecting a motor drive unit, make sure to refer to the power supply specifications and the I/O specifications described in Section 2 and observe the cautions.

- I/O connection of the FX-10GM with a stepping motor ..... Refer to page 8-2.
- I/O connection of the FX-10GM with a MR-C servo motor ..... Refer to page 8-3.
- I/O connection of the FX-10GM with a MR-J servo motor ..... Refer to page 8-4.
- I/O connection of the FX-10GM with a MR-J2 servo motor ..... Refer to page 8-5.
- I/O connection of the FX-10GM with a MR-H servo motor ..... Refer to page 8-6.
- I/O connection of the FX(E)-20GM with a stepping motor ..... Refer to page 8-7.
- I/O connection of the FX(E)-20GM with a MR-C servo motor ..... Refer to page 8-8.
- I/O connection of the FX(E)-20GM with a MR-J servo motor ..... Refer to page 8-9.
- I/O connection of the FX(E)-20GM with the MR-J2 servo motor ..... Refer to page 8-10.
- I/O connection of the FX(E)-20GM with the MR-H servo motor ..... Refer to page 8-11.

I/O connection example

Figure:8.1 When the FX-10GM is connected to a stepping motor.

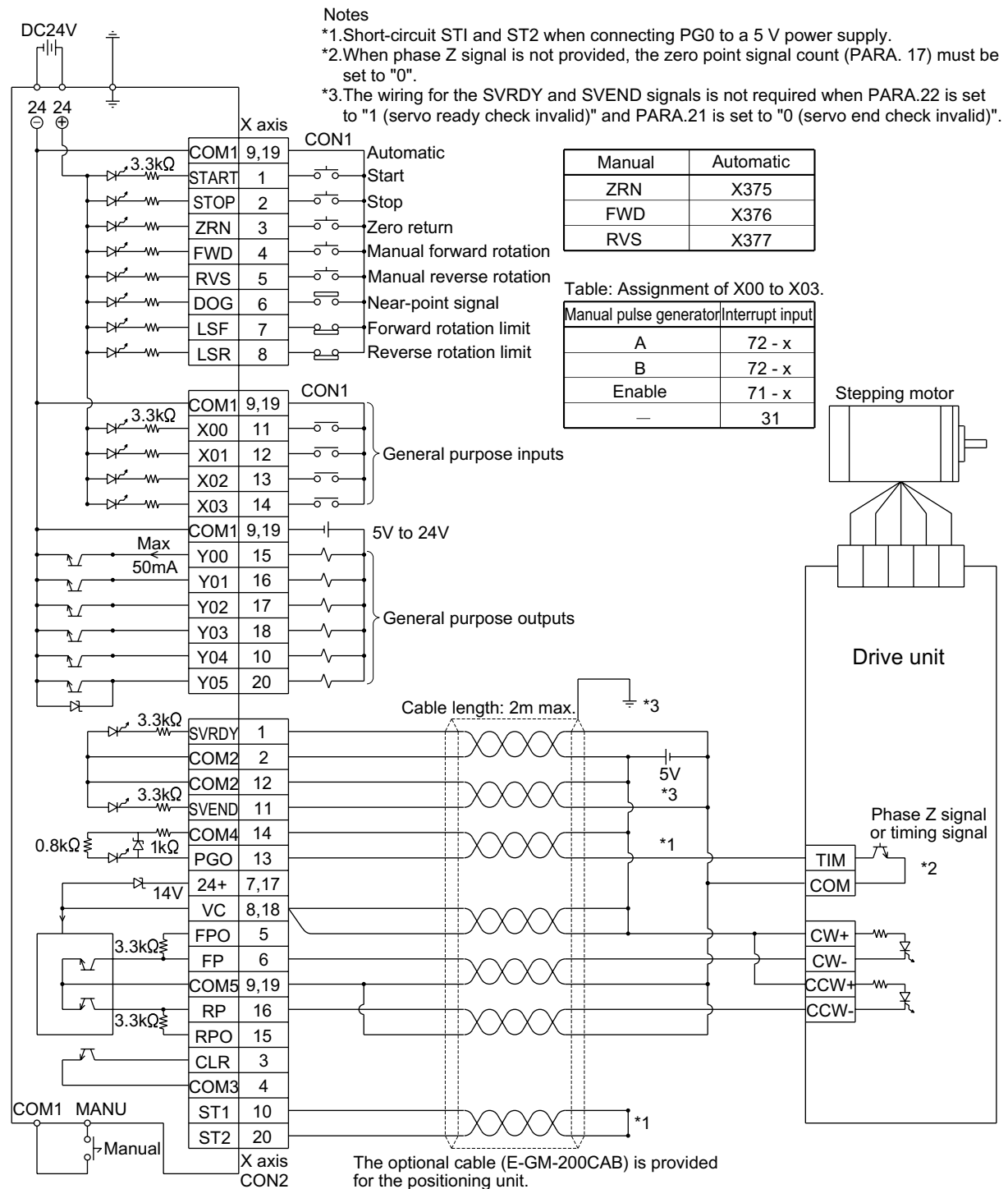



I/O connection example

Figure:8.2 When the FX-10GM is connected to a MR-C servo motor.

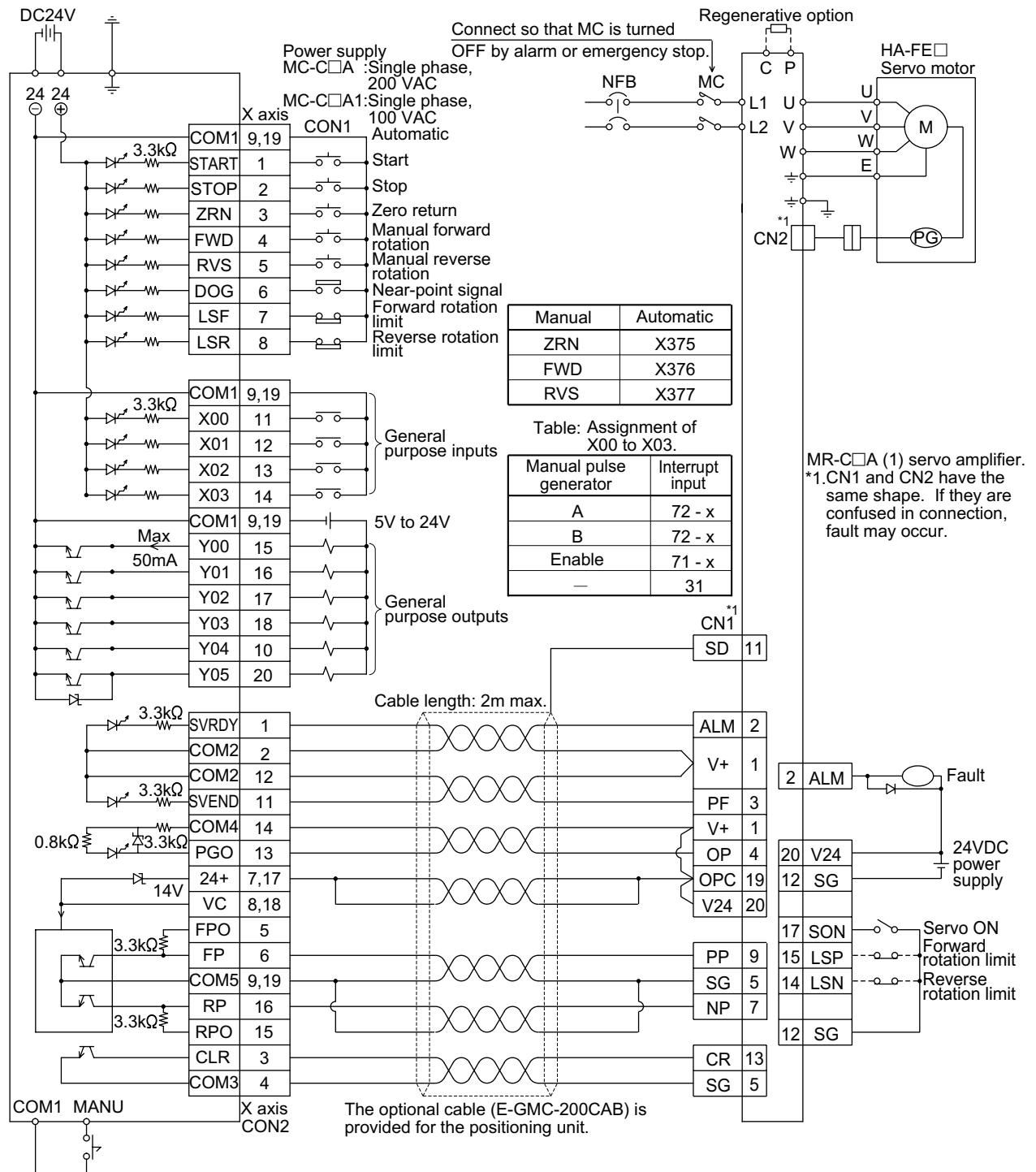

I/O connection example

Figure:8.3 When the FX-10GM is connected to a MR-J servo motor.

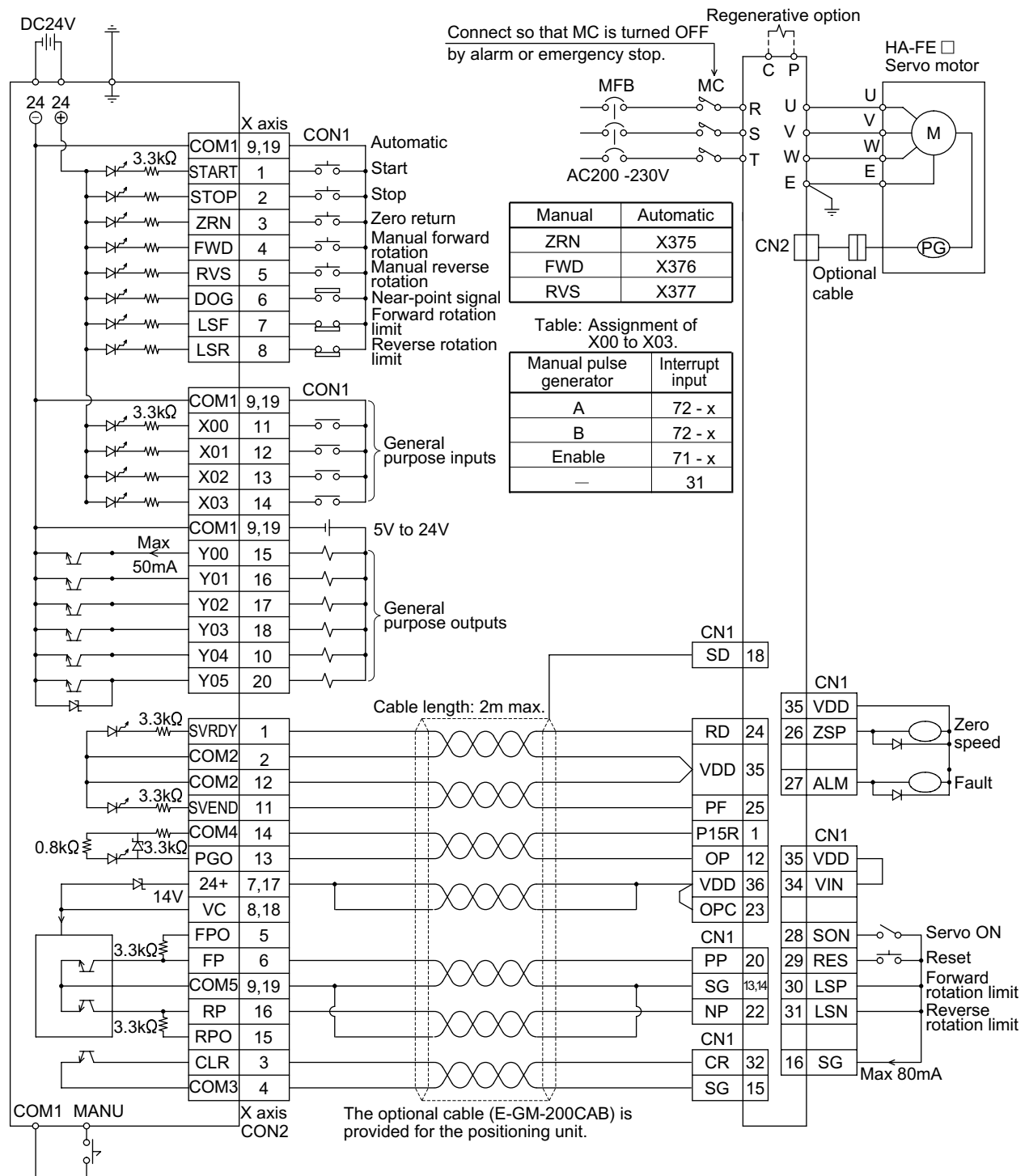

I/O connection example

Figure:8.4 When the FX-10GM is connected to a MR-J2 servo motor.

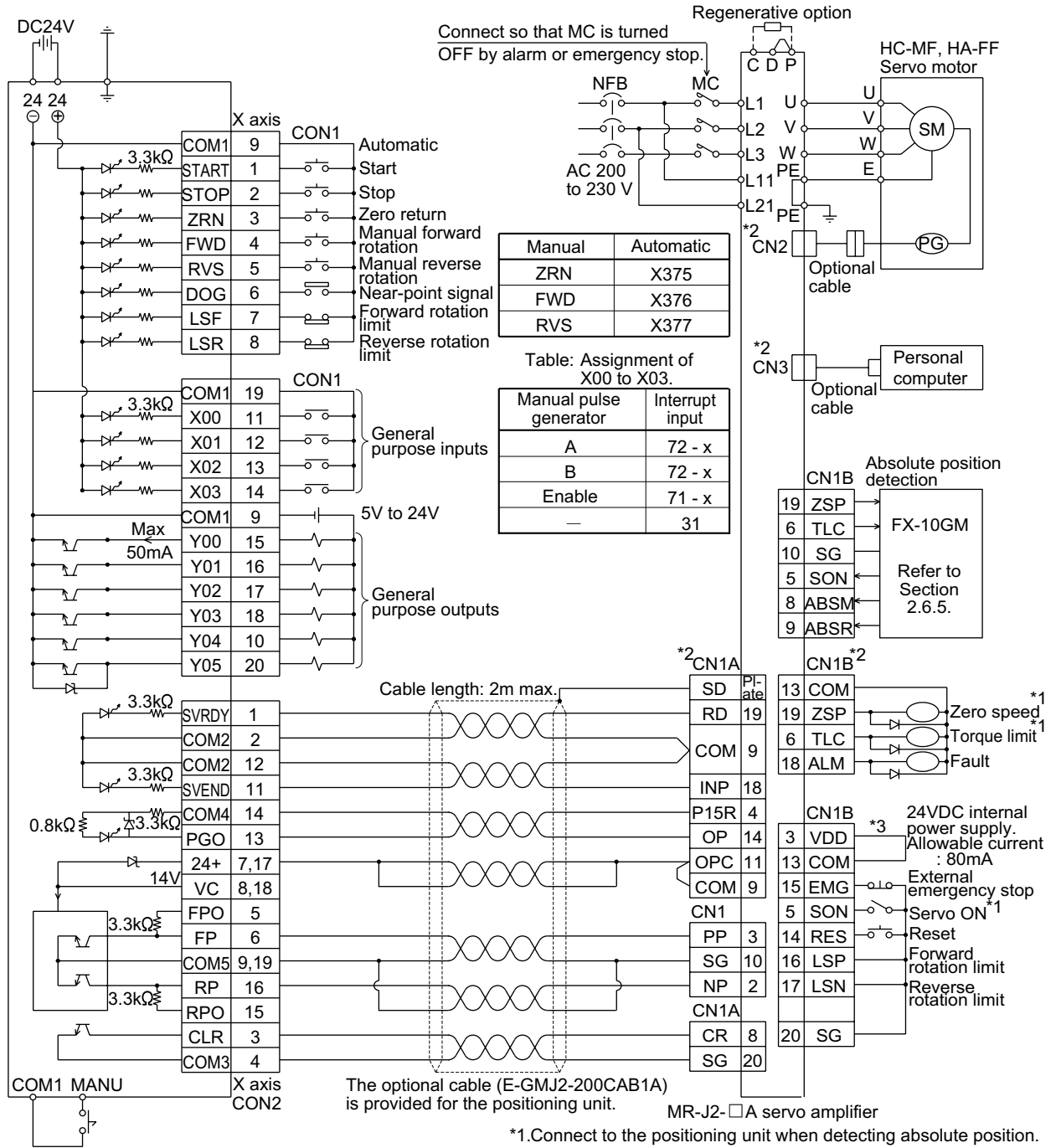

\*1. Connect to the positioning unit when detecting absolute position.  
 \*2. CN1A, CN1B, CN2 and CN3 have the same shape. If they are confused in connection, fault may occur.  
 \*3. Connect when using the internal power supply.

I/O connection example

Figure:8.5 When the FX-10GM is connected to a MR-H servo motor.

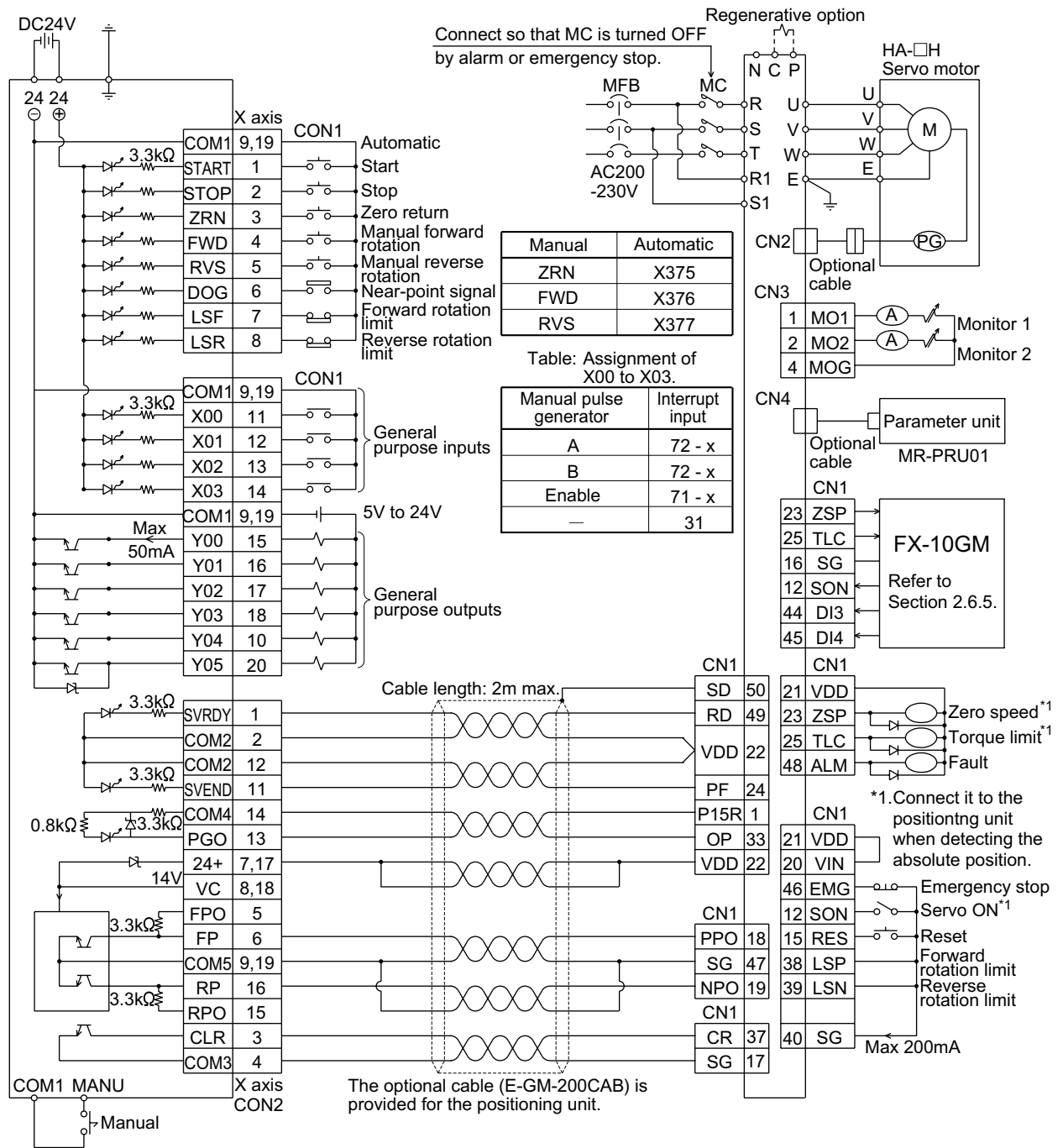

I/O connection example

Figure:8.6 When the FX(E)-20GM is connected to a stepping motor.

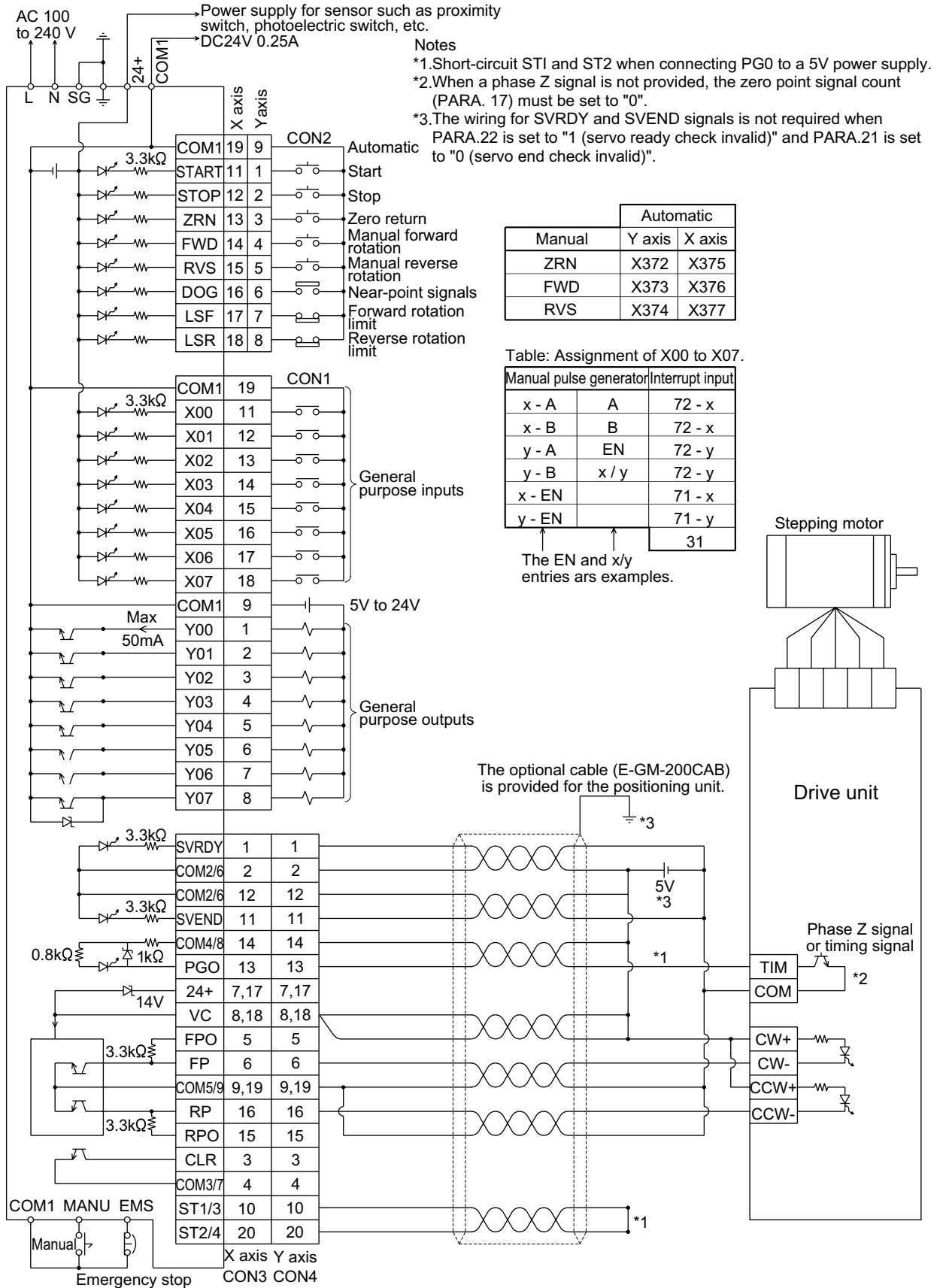

I/O connection example

Figure:8.7 When the FX(E)-20GM is connected to a MR-C servo motor.

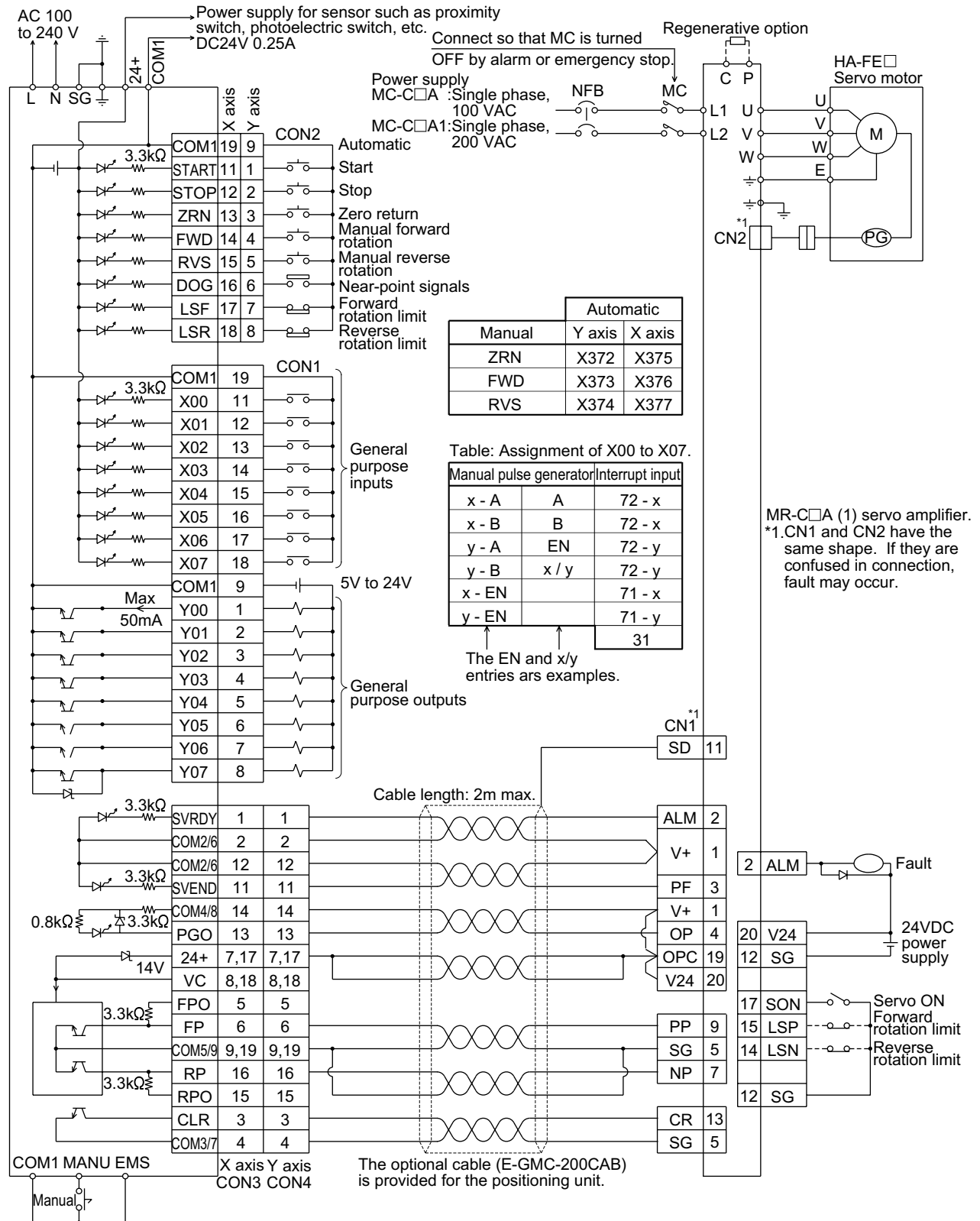



I/O connection example

Figure:8.9 When the FX(E)-20GM is connected to the MR-J2 servo motor.

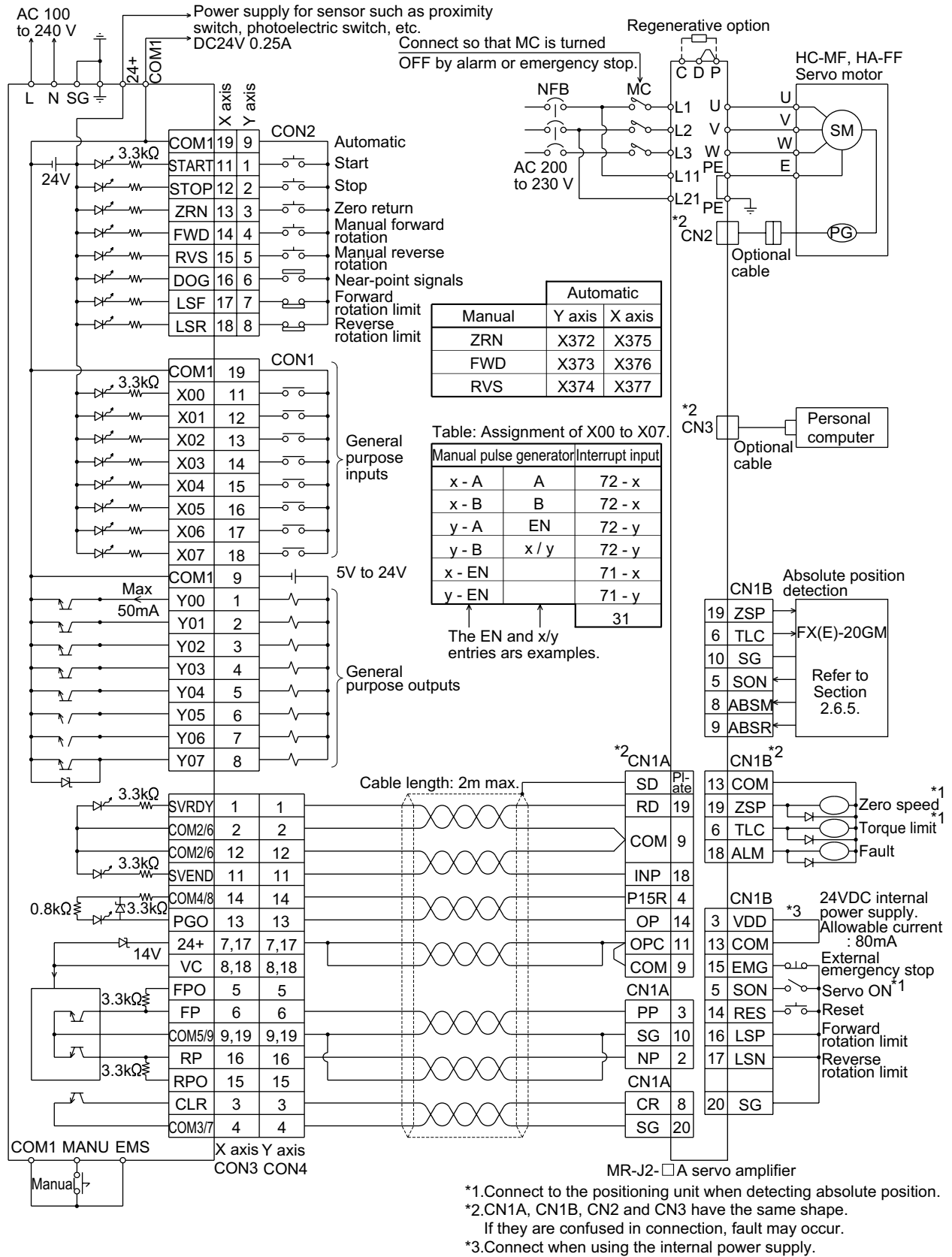



I/O connection example

Figure:8.10 When the FX(E)-20GM is connected to the MR-H servo motor.

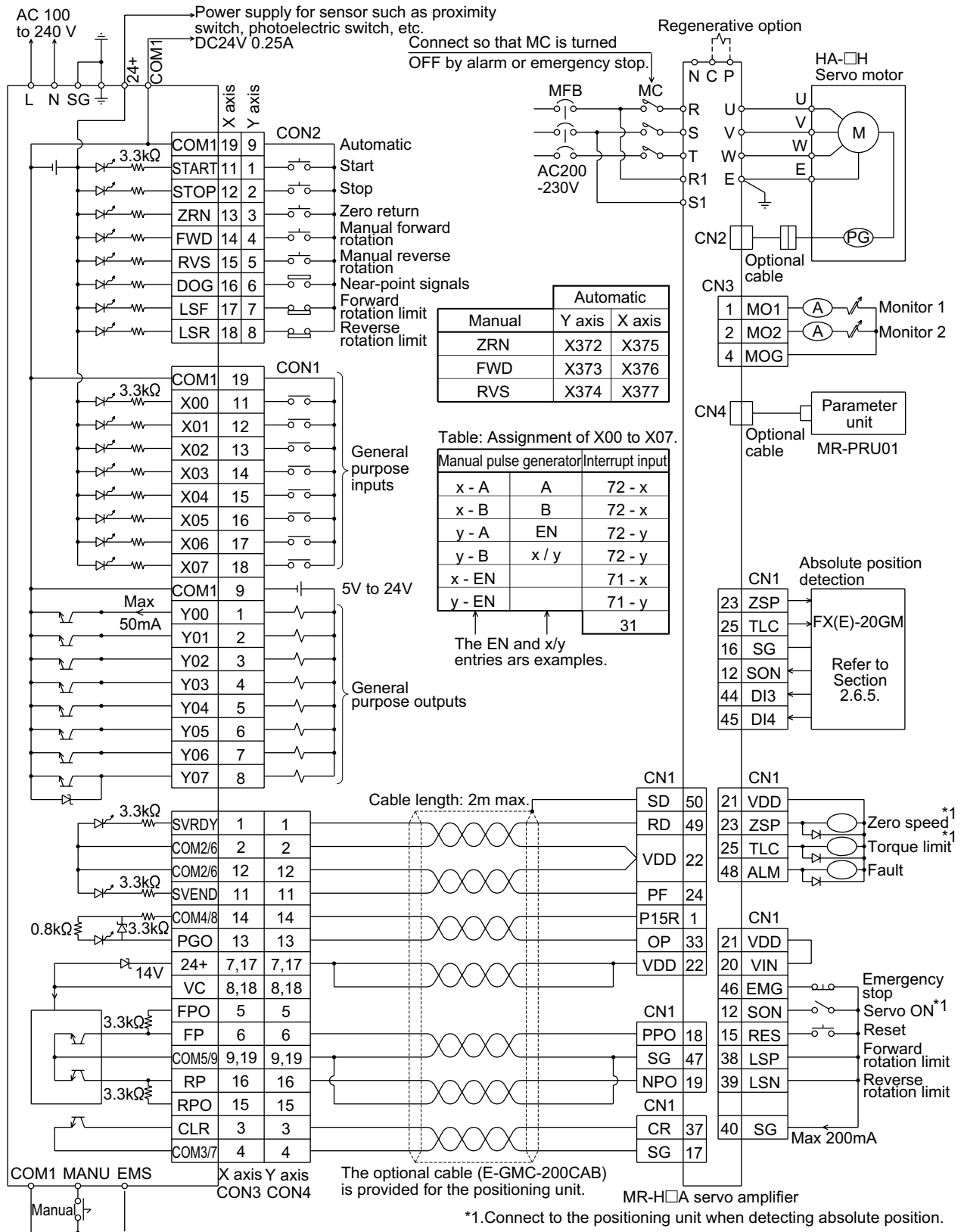

# MEMO

## 9. SUPPLEMENTAL ITEMS

This section explains the extended functions of the FX-10GM/FX(E)-20GM.

- Compensation ignore function added for incremental drive. ... Section 9.1
- Teaching function added in AUTO mode. .... Section 9.2
- Positioning using the table method (FX-10GM). .... Section 9.3

### 9.1 Compensation ignore function added for incremental drive

Applicable products and versions

**Table:9.1** *Applicable products and versions*

Product model name	Applicable version
Single-axis positioning unit FX-10GM.	Ver. 1.20 shipped in Sep. 1996 or later (Serial No. 69****).
Two-axis positioning unit FX-20GM, E-20GM.	Ver. 3.10 shipped in Aug. 1996 or later (Serial No. 68****).

Description

- New special auxiliary relays M9163 (X axis) and M9164 (Y axis) are provided. While these relays are turned ON, compensation using cod 73, cod 74 and cod 75 are ignored and operation is performed without compensation during incremental drive (while cod 91 INC instruction is executed).

## 9.2 Teaching function added in AUTO mode

Applicable products and versions

**Table:9.2 Applicable products and versions**

Product model name	Applicable version
Single-axis positioning unit FX-10GM.	Ver. 1.20 shipped in Sep. 1996 or later (Serial No. 69****).
Two-axis positioning unit FX-20GM, E-20GM.	Ver. 3.10 shipped in Aug. 1996 or later (Serial No. 68****).
Teaching panel E-20TP.	Ver. 1.20 shipped in Aug. 1996 or later (Serial No. 68****).

The software for personal computers (FX-PCS-KIT-GM-EE) is not equipped with the teaching function in the AUTO mode (The teaching function is available in the MANU mode.).

### Description

- **Outline**  
The conventional teaching function is valid while the positioning unit is in MANU mode. In the models of the versions shown in the table above, the teaching function is valid also in AUTO mode.  
The teaching function sets the present value, changed by manual operation (JOG+, JOG-) performed from the teaching panel E-20TP, as the target value (address value) in the program.
- **Special auxiliary relay (M9161) added.**  
The special auxiliary relay (M9161) must be turned ON to perform teaching in AUTO mode. While M9161 is turned ON, teaching is enabled in AUTO mode from the E-20TP.  
M9161 can be turned ON using the forced ON/OFF function of the teaching panel or in the program as shown below.

Program example:

```
Ox10, No. .... X axis, Y axis (O, Ox, Oy) or subtask (O100) program
SET M9161; ..... Teaching is valid in the AUTO mode.
      )
      ( Once M9161 is turned ON using the SET instruction, teaching is
        valid in AUTO mode until the power is turned OFF.
```

## 9.3 Positioning using the table method (FX-10GM)

In the Single-axis positioning unit FX-10GM of the following version, a new function is added so that positioning is enabled using the FROM/TO instructions of the PC. This function allows positioning control operations using peripheral equipment for the PC even when peripheral equipment dedicated to the positioning unit is not available.

Applicable products and versions

**Table:9.3** *Applicable products and versions*

Product model name	Applicable version
Single-axis positioning unit FX-10GM.	Ver. 1.30 shipped in Oct. 1996 or later (Serial No. 6X****).
PC FX or FX2C Series	Ver. 2.00 shipped in Apr. 1991 or later (Serial No. 14****). All products of FX2C Series

### Outline of the table function

When the special auxiliary relay M9165 of the FX-10GM is turned ON, positioning control using the table method becomes valid.

A maximum of 100 table entries are provided. Each entry holds four types of information: command code (corresponding to the instruction), position data (address), speed data and M code value. The information is saved in the general-purpose registers of the positioning unit. Two data registers (32 bits) are used to save one piece of information.

The data register No. and the table entry No. (described later) are fixed. D1000 is assigned to entry No. 0. (One hundred entries No. 0 to 99 are available.)

When the positioning data is written to the assigned data registers using the TO instruction and operation is started, positioning is performed based on the written information.

Declaration of table method

- To use the table method, the special auxiliary relay M9165 of the FX-10GM must be turned ON.

M9165 ..... Table method function valid (Buffer memory #30 b5)

Sequence program example (switches M9165 ON):

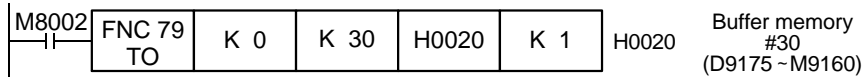

- Once M9165 is turned ON, it remains ON until the power is turned OFF. Accordingly, once the table method is declared, it remains valid until the power is turned OFF.

Assignment of table data

- When the table method becomes valid, the data registers D1000 to D1999 of the FX-10GM are assigned as the positioning data storage registers. (The data is not backed up by the battery.)
- One hundred entries No. 0 to 99 are provided. Four types of information, command code, position data, speed data and M code, are assigned to each entry. Two data registers (32 bits) are allocated for each piece of information. Accordingly, each entry occupies eight data registers.

Operation instruction is specified.

Travel address is specified.

Operation speed is specified.

M code is specified.

Entry No.	Command code	Position data	Speed data	M code
Nb. 0	D1000, D1001	D1002, D1003	D1004, D1005	D1006, D1007
Nb. 1	D1010, D1011	D1012, D1013	D1014, D1015	D1016, D1017
Nb. 2	D1020, D1021	D1022, D1023	D1024, D1025	D1026, D1027
⋮				
Nb. 98	D1980, D1981	D1982, D1983	D1982, D1983	D1986, D1987
Nb. 99	D1990, D1991	D1992, D1993	D1992, D1993	D1996, D1997

100 entries (No. 0 to 99) are available.

(For a full table list, refer to pages 9-13 and 9-14.)

The data register No. are allocated according to each entry No.  
 (For example, entry No. 58 is assigned to D1580 to D1587).

The data registers are changed in accordance with the M9165 state as shown in the table below.

M9165 state	Parameter buffer (D9000 onward)	Data registers (D0 to D1999)
ON	Not changed by changeover between MANU and AUTO.	Not changed by changeover between MANU and AUTO.
OFF	Initialized when MANU is changed to AUTO.	Cleared to 0 when AUTO is changed to MANU.

Setting of positioning data

- Command code

Specify the operation such as high-speed positioning (DRV), returning to the mechanical zero point (DRVZ), etc. which corresponds to a positioning instruction as the command code.

Command code	Description	Command code	Description
0	High-speed positioning.	71	Interrupt jog feed at one-step speed.
1	Multi speed operation.	72	Interrupt jog feed at two-step speed. (Two entries are used.)
4	Timer.		
9	Servo end check.	73	Travel compensation.
28	Returning to mechanical zero point.	76	Cancel of compensation.
29	Setting of electrical zero point.	90	Specification of absolute address.
30	Returning to electrical zero point.	91	Specification of incremental address.
31	Interrupt stop (Remaining distance is ignored).	92	Change of present value.

This number determines the positioning operation.  
This value is equivalent to the cod No. (Refer to Chapter 5.).

WAIT instruction (m00)

When “1” is added at the head of the two-digit command code, the WAIT instruction (m00) is included in the operation.

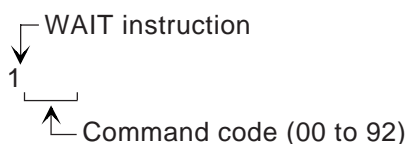

Example

171: When the command code is set to “171”, interrupt jog feed is performed, then the unit enters the WAIT (m 00) state and waits for start.

END instruction (m 02)

When “2” is added at the head of the two-digit command code, the END instruction (m 02) is included in the operation.

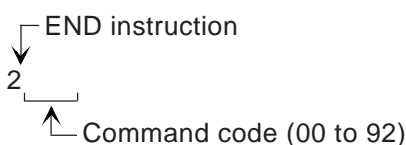

Example

231: When the command code is set to “231”, interrupt stop is performed, then the unit performs the END (m 02) command.

- **Position data**  
Set the travel distance or address as the position data.  
Some instructions do not require position data to be set. Refer to the list below.  
The setting range is equivalent to that for the cod instructions. Refer to Section 5.
- **Speed data**  
Set the operation speed for positioning as the speed data.  
The setting range is equivalent to that for the cod instructions. Refer to Section 5.
- **M code**  
The M code is output to the PC in either WITH or AFTER mode. The M code output in AFTER mode (where the m code is output after the positioning operation is completed) or WITH mode (where the m code is output at the same time as the positioning operation is performed) can be set.  
Setting           0:           The m code is not output.  
                  1 to 99:       The m code is output in AFTER mode.  
                 100 to 199: The m code is output in WITH mode.

**Positioning data list**

The table below shows the list of information set for each command code. The items marked with “O” are required to be set. When a value is entered for an item indicated as “Undefined”, it is ignored.

The command code “72” indicates interrupt jog feed at two-step speed, and uses two entries because two speeds are required to be set (Refer to the next page.).

Command code	Position data	Speed data	M code	Remarks
0		1		High-speed positioning.
1				Multi speed operation.
4		Undefined		Timer.
9	Undefined	Undefined		Servo end check.
28	Undefined	Undefined		Return to mechanical zero point.
29	Undefined	Undefined		Setting of electrical zero point.
30	Undefined	Undefined		Return to electrical zero point.
31				Interrupt stop (Remaining distance is neglect)
71				Interrupt jog feed at one-step speed.
72			Undefined	Interrupt jog feed at two-step speed.
Undefined	Undefined			(Two entries are used.)
73		Undefined		Travel compensation.
76	Undefined	Undefined		Cancel of compensation.
90	Undefined	Undefined		Specification of absolute address.
91	Undefined	Undefined		Specification of incremental address.
92		Undefined		Change of present value.

1 When the speed data is set to “0”, the command code (0) is ignored and the next entry is executed.



### Cautions on command codes

#### 1. Handling of command code 0 (high-speed positioning)

When the speed is set to "0" no processing is performed and the entry is skipped. Though the speed can be omitted in the cod 00 instruction, it cannot be omitted in the table method.

#### 2. Handling of command code 72 (interrupt jog feed at two-step speed)

When 72 (interrupt jog feed at two-step speed) is set, two speed commands are required. Make sure to use two entries.

Table No.0	72	] Two entries make one positioning operation.
Table No.1	72	
⋮		
Table No.10	72	] Even if only one entry is set for "72" the next entry (No. 11) is regarded as the second-step speed of "72".
Table No.11	01	

#### 3. Error information

Appropriate error codes are generated in the same way as positioning using instructions.

For the meaning of errors and the troubleshooting procedures, refer to Section 3.4.

### Handling of parameters

- The positioning parameters and the I/O control parameters can be written from the PC. (The system parameters cannot be changed.)
- When the power is turned ON, the initial values (default values) are set to the parameters. When the parameter data is changed from the PC, the corresponding parameters are changed. When the power is turned OFF, the parameters are returned to the initial values. Make sure to set the parameters as necessary after the power is turned ON.
- For the parameter change procedures, refer to pages 4-31, 32 and page 7-11.

**Table method operation**

- In the table method operation, the special data register D9000 specifies the start (first) table entry No. When the start input is given, the commands are executed in turn starting with the table entry No. saved in D9000.

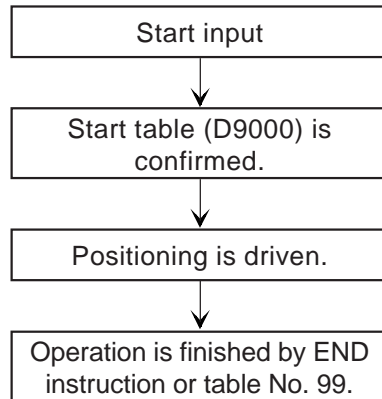

- When the external start terminal or M9001 is turned ON, the table program is executed.
- When the start input is turned ON, the positioning unit confirms the contents of the start entry (D9000) and executes from the specified entry No.
- The commands are executed in turn from the start entry to entry No. 99. If the END instruction (Command code: 2 ) is present, the operation finishes there. If the END instruction is not present, the operation finishes at entry No. 99.

- The following special auxiliary relays and data registers are related to start and stop of the table method operation.

	Special M/D	Buffer memory (BFM)
Start	M9001	#20 b1 or external start input
Stop	M9002	#20 b2 or external stop input
Start entry No.	D9000	#0 or #9000
Activated start entry No.	D9001	#1 or #9001
Entry No. being executed.	D9002	#2 or #9002

Program example

- An example program using the table method is described below.

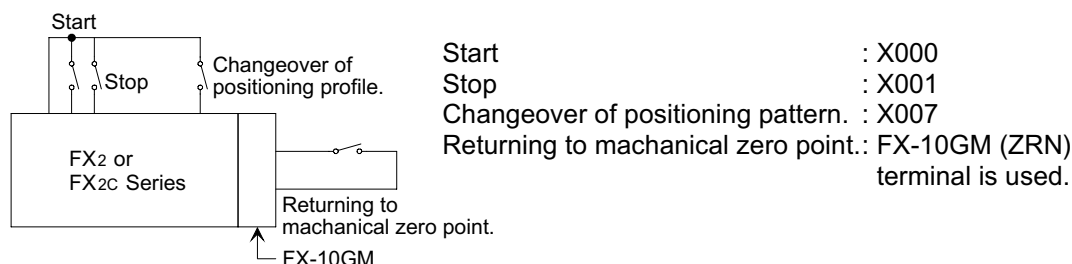

Contents of operation

- The positioning control profiles 1 or 2 shown below can be performed.
- When the profile change over input X007 is OFF, profile 1 is executed. When the X007 is ON, profile 2 is executed.
- Return to mechanical zero point should be done by manual operation (External ZRN terminal input: ON) before the table program is executed.

Profile 1: Operation in the incremental drive method.

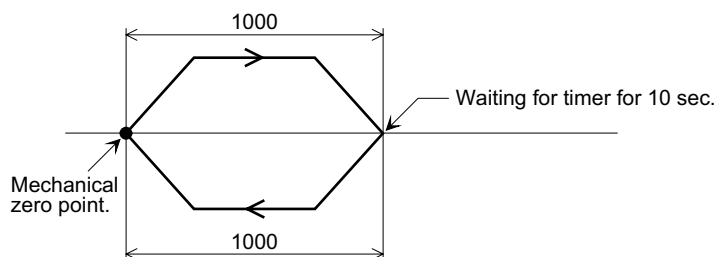

Table:9.4

Entry No.	Command code	Position data	Speed data	M code	Remarks	
0	Data register	D1001, D1000	D1003, D1002	D1005, D1004	D1007, D1006	Incremental (INC) address is specified
	Set value	K91	K0 (Undefined.)	K0 (Undefined.)	K0 (Not required to be set.)	
1	Data register	D1011, D1010	D1013, D1012	D1015, D1014	D1017, D1016	High-speed feed to +1000 position. Speed: 2000
	Set value	K0	K1000	K2000	K0 (Not required to be set.)	
2	Data register	D1021, D1020	D1023, D1022	D1025, D1024	D1027, D1026	Waiting for timer for 10 sec. M code 10 is output simultaneously.
	Set value	K4	K1000	K0 (Undefined.)	K110	
3	Data register	D1031, D1030	D1033, D1032	D1035, D1034	D1037, D1036	High-speed feed to -1000 position (zero)
	Set value	K0	K-1000	K2000	K0 (Not required to be set.)	
4	Data register	D1041, D1040	D1043, D1042	D1045, D1044	D1047, D1046	Waiting for timer for 5 sec. END state.
	Set value	K204	K500	K0 (Undefined.)	K0 (Not required to be set.)	

Profile 2: Operation in the absolute drive method (Operation is same as described on page 5-16.)

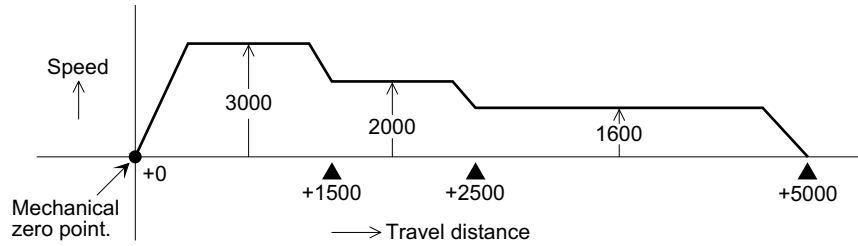
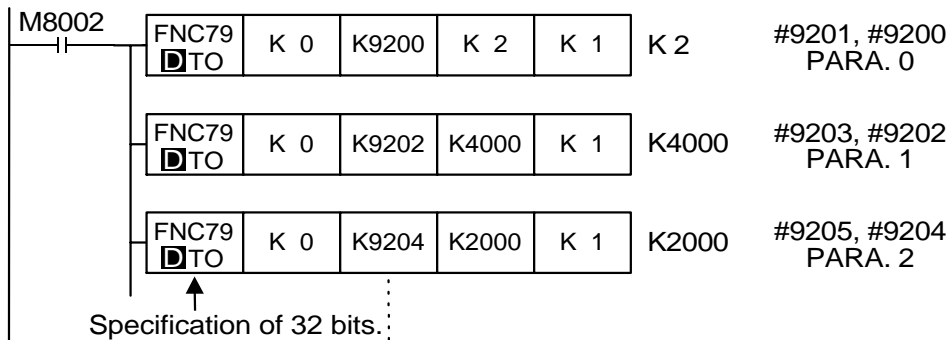

Table:9.5

Entry No.	Command code	Position data	Speed data	M code	Remarks	
10	Data register	D1101, D1100	D1103, D1102	D1105, D1104	D1107, D1106	Absolute (ABS) address is specified
	Set value	K90	K0 (Undefined)	K0 (Undefined)	K0 (Not required to be set.)	
11	Data register	D1111, D1110	D1113, D1112	D1115, D1114	D1117, D1116	Multi speed operation is started. Unit travels at speed 3000 up to +1500 position.
	Set value	K1	K1500	K3000	K0 (Not required to be set.)	
12	Data register	D1121, D1120	D1123, D1122	D1125, D1124	D1127, D1126	Multi speed operation is performed. Unit travels at speed 2000 up to +2500 position.
	Set value	K1	K2500	K2000	K0 (Not required to be set.)	
13	Data register	D1131, D1130	D1133, D1132	D1135, D1134	D1137, D1136	Multi speed operation is finished. Unit travels at speed 1600 up to +5000 position.
	Set value	K201	K5000	K1600	K0 (Not required to be set.)	

- Changing the parameters  
The set values of the positioning parameters (No. 0 to 26) can be changed. When the power is turned ON, the initial values (described on page 4-16) <sup>1</sup> are restored. Write the parameters to be changed using the TO instruction.



Only parameters to be changed need to be written.

1 If the parameters have been changed by the E-20TP or the FX-PCS-KIT-GM/AT-EE (software for personal computers), these values are restored at power ON.

- Declaring the table method.  
Turn ON the special auxiliary relay M9165 so that positioning control using the table method becomes valid.

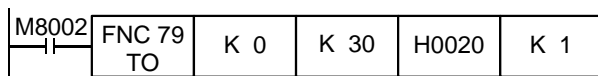

**Specifying the start point**

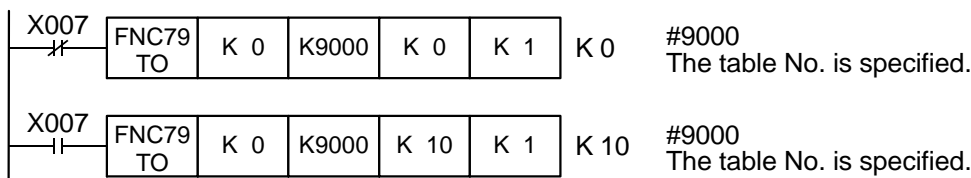

- Setting the operation mode.  
Set the commands for start/stop, return to the mechanical zero point (ZRN), manual forward movement (FWD) and manual backward movement (RVS). These commands can also be given from the input terminal of the FX-10GM. Both the commands from the program and the commands from the input terminal are processed in parallel and become valid inside the 10GM.

**Operation mode commands**

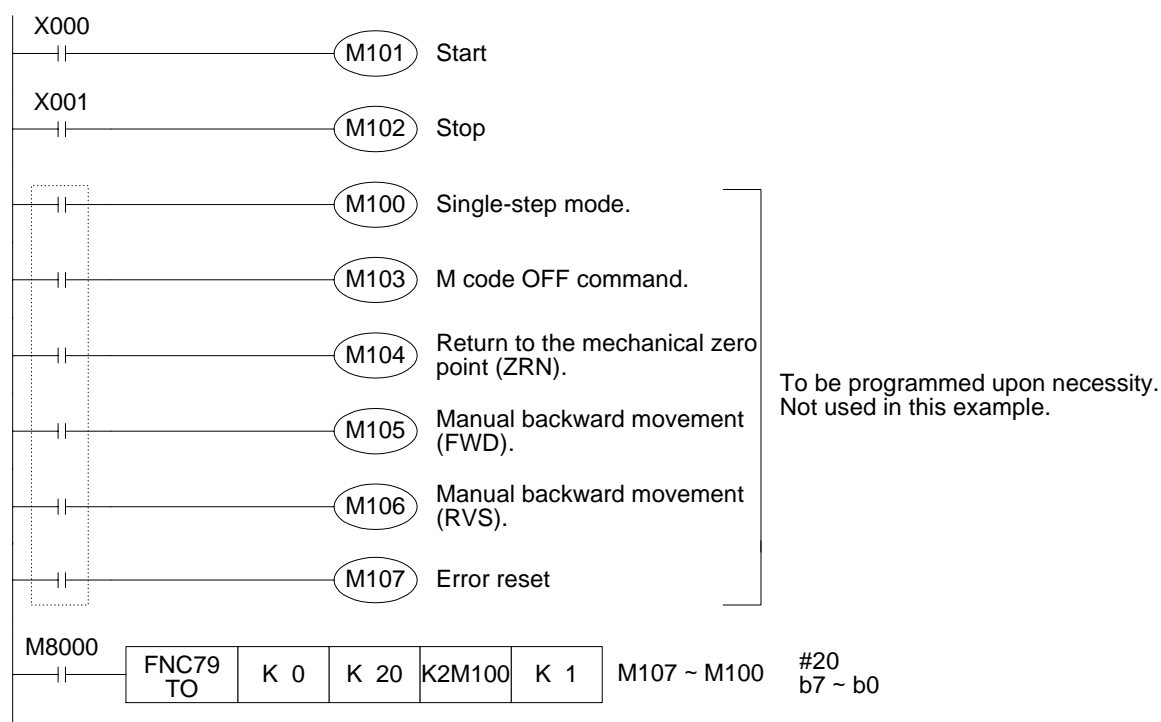

### Setting the table entries

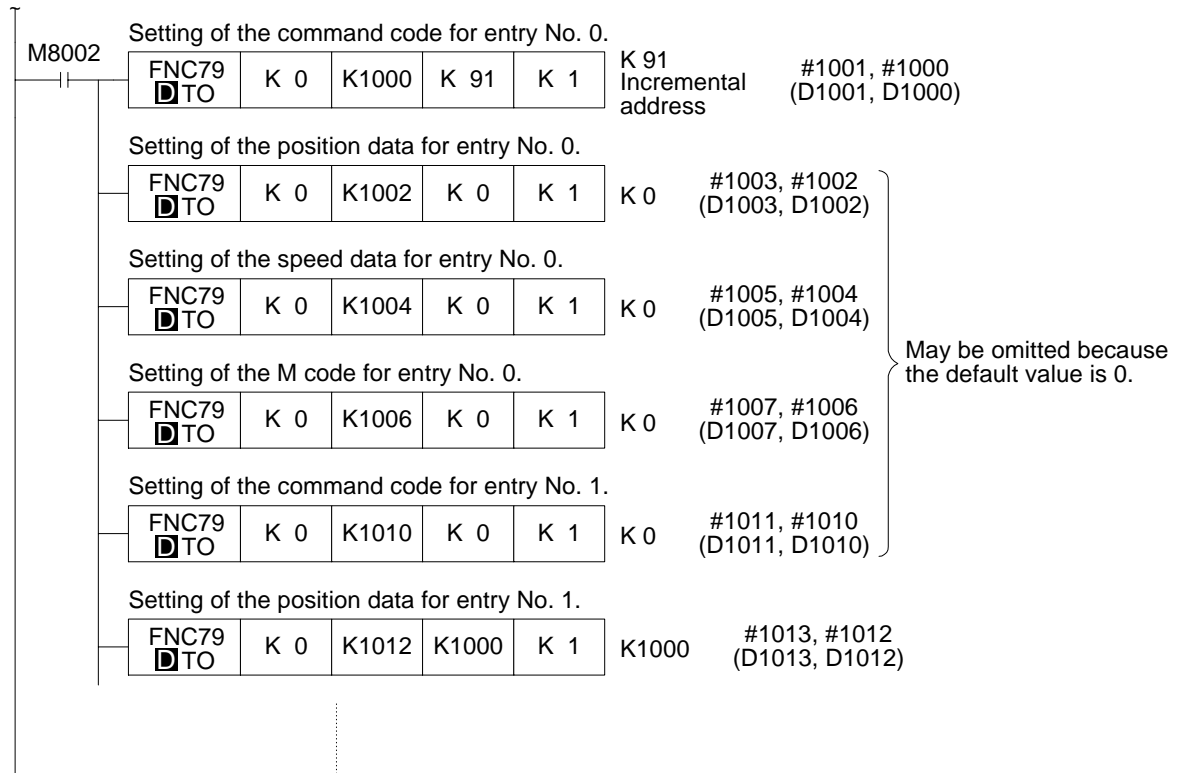

Note: While the table is initialised, the watchdog timer (WDT) may be activated and a CPU error may occur. In this case, set a large value to the register D8000 (watchdog timer) and insert the FNC 07 (WDT) instruction in the program so that the WDT is refreshed within 100 ms.

Table:9.6 Table information list

Entry No.	Command code	Position data	Speed data	M code
0	D1001, D1000	D1003, D1002	D1005, D1004	D1007, D1006
1	D1011, D1010	D1013, D1012	D1015, D1014	D1017, D1016
2	D1021, D1020	D1023, D1022	D1025, D1024	D1027, D1026
3	D1031, D1030	D1033, D1032	D1035, D1034	D1037, D1036
4	D1041, D1040	D1043, D1042	D1045, D1044	D1047, D1046
5	D1051, D1050	D1053, D1052	D1055, D1054	D1057, D1056
6	D1061, D1060	D1063, D1062	D1065, D1064	D1067, D1066
7	D1071, D1070	D1073, D1072	D1075, D1074	D1077, D1076
8	D1081, D1080	D1083, D1082	D1085, D1084	D1087, D1086
9	D1091, D1090	D1093, D1092	D1095, D1094	D1097, D1096
10	D1101, D1100	D1103, D1102	D1105, D1104	D1107, D1106
11	D1111, D1110	D1113, D1112	D1115, D1114	D1117, D1116
12	D1121, D1120	D1123, D1122	D1125, D1124	D1127, D1126
13	D1131, D1130	D1133, D1132	D1135, D1134	D1137, D1136
14	D1141, D1140	D1143, D1142	D1145, D1144	D1147, D1146
15	D1151, D1150	D1153, D1152	D1155, D1154	D1157, D1156
16	D1161, D1160	D1163, D1162	D1165, D1164	D1167, D1166
17	D1171, D1170	D1173, D1172	D1175, D1174	D1177, D1176
18	D1181, D1180	D1183, D1182	D1185, D1184	D1187, D1186
19	D1191, D1190	D1193, D1192	D1195, D1194	D1197, D1196
20	D1201, D1200	D1203, D1202	D1205, D1204	D1207, D1206
21	D1211, D1210	D1213, D1212	D1215, D1214	D1217, D1216
22	D1221, D1220	D1223, D1222	D1225, D1224	D1227, D1226
23	D1231, D1230	D1233, D1232	D1235, D1234	D1237, D1236
24	D1241, D1240	D1243, D1242	D1245, D1244	D1247, D1246
25	D1251, D1250	D1253, D1252	D1255, D1254	D1257, D1256
26	D1261, D1260	D1263, D1262	D1265, D1264	D1267, D1266
27	D1271, D1270	D1273, D1272	D1275, D1274	D1277, D1276
28	D1281, D1280	D1283, D1282	D1285, D1284	D1287, D1286
29	D1291, D1290	D1293, D1292	D1295, D1294	D1297, D1296
30	D1301, D1300	D1303, D1302	D1305, D1304	D1307, D1306
31	D1311, D1310	D1313, D1312	D1315, D1314	D1317, D1316
32	D1321, D1320	D1323, D1322	D1325, D1324	D1327, D1326
33	D1331, D1330	D1333, D1332	D1335, D1334	D1337, D1336
34	D1341, D1340	D1343, D1342	D1345, D1344	D1347, D1346
35	D1351, D1350	D1353, D1352	D1355, D1354	D1357, D1356
36	D1361, D1360	D1363, D1362	D1365, D1364	D1367, D1366
37	D1371, D1370	D1373, D1372	D1375, D1374	D1377, D1376
38	D1381, D1380	D1383, D1382	D1385, D1384	D1387, D1386
39	D1391, D1390	D1393, D1392	D1395, D1394	D1397, D1396
40	D1401, D1400	D1403, D1402	D1405, D1404	D1407, D1406
41	D1411, D1410	D1413, D1412	D1415, D1414	D1417, D1416
42	D1421, D1420	D1423, D1422	D1425, D1424	D1427, D1426
43	D1431, D1430	D1433, D1432	D1435, D1434	D1437, D1436
44	D1441, D1440	D1443, D1442	D1445, D1444	D1447, D1446
45	D1451, D1450	D1453, D1452	D1455, D1454	D1457, D1456
46	D1461, D1460	D1463, D1462	D1465, D1464	D1467, D1466
47	D1471, D1470	D1473, D1472	D1475, D1474	D1477, D1476
48	D1481, D1480	D1483, D1482	D1485, D1484	D1487, D1486
49	D1491, D1490	D1493, D1492	D1495, D1494	D1497, D1496

Entry Nb.	Command code	Position data	Speed data	M code
50	D1501, D1500	D1503, D1502	D1505, D1504	D1507, D1506
51	D1511, D1510	D1513, D1512	D1515, D1514	D1517, D1516
52	D1521, D1520	D1523, D1522	D1525, D1524	D1527, D1526
53	D1531, D1530	D1533, D1532	D1535, D1534	D1537, D1536
54	D1541, D1540	D1543, D1542	D1545, D1544	D1547, D1546
55	D1551, D1550	D1553, D1552	D1555, D1554	D1557, D1556
56	D1561, D1560	D1563, D1562	D1565, D1564	D1567, D1566
57	D1571, D1570	D1573, D1572	D1575, D1574	D1577, D1576
58	D1581, D1580	D1583, D1582	D1585, D1584	D1587, D1586
59	D1591, D1590	D1593, D1592	D1595, D1594	D1597, D1596
60	D1601, D1600	D1603, D1602	D1605, D1604	D1607, D1606
61	D1611, D1610	D1613, D1612	D1615, D1614	D1617, D1616
62	D1621, D1620	D1623, D1622	D1625, D1624	D1627, D1626
63	D1631, D1630	D1633, D1632	D1635, D1634	D1637, D1636
64	D1641, D1640	D1643, D1642	D1645, D1644	D1647, D1646
65	D1651, D1650	D1653, D1652	D1655, D1654	D1657, D1656
66	D1661, D1660	D1663, D1662	D1665, D1664	D1667, D1666
67	D1671, D1670	D1673, D1672	D1675, D1674	D1677, D1676
68	D1681, D1680	D1683, D1682	D1685, D1684	D1687, D1686
69	D1691, D1690	D1693, D1692	D1695, D1694	D1697, D1696
70	D1701, D1700	D1703, D1702	D1705, D1704	D1707, D1706
71	D1711, D1710	D1713, D1712	D1715, D1714	D1717, D1716
72	D1721, D1720	D1723, D1722	D1725, D1724	D1727, D1726
73	D1731, D1730	D1733, D1732	D1735, D1734	D1737, D1736
74	D1741, D1740	D1743, D1742	D1745, D1744	D1747, D1746
75	D1751, D1750	D1753, D1752	D1755, D1754	D1757, D1756
76	D1761, D1760	D1763, D1762	D1765, D1764	D1767, D1766
77	D1771, D1770	D1773, D1772	D1775, D1774	D1777, D1776
78	D1781, D1780	D1783, D1782	D1785, D1784	D1787, D1786
79	D1791, D1790	D1793, D1792	D1795, D1794	D1797, D1796
80	D1801, D1800	D1803, D1802	D1805, D1804	D1807, D1806
81	D1811, D1810	D1813, D1812	D1815, D1814	D1817, D1816
82	D1821, D1820	D1823, D1822	D1825, D1824	D1827, D1826
83	D1831, D1830	D1833, D1832	D1835, D1834	D1837, D1836
84	D1841, D1840	D1843, D1842	D1845, D1844	D1847, D1846
85	D1851, D1850	D1853, D1852	D1855, D1854	D1857, D1856
86	D1861, D1860	D1863, D1862	D1865, D1864	D1867, D1866
87	D1871, D1870	D1873, D1872	D1875, D1874	D1877, D1876
88	D1881, D1880	D1883, D1882	D1885, D1884	D1887, D1886
89	D1891, D1890	D1893, D1892	D1895, D1894	D1897, D1896
90	D1901, D1900	D1903, D1902	D1905, D1904	D1907, D1906
91	D1911, D1910	D1913, D1912	D1915, D1914	D1917, D1916
92	D1921, D1920	D1923, D1922	D1925, D1924	D1927, D1926
93	D1931, D1930	D1933, D1932	D1935, D1934	D1937, D1936
94	D1941, D1940	D1943, D1942	D1945, D1944	D1947, D1946
95	D1951, D1950	D1953, D1952	D1955, D1954	D1957, D1956
96	D1961, D1960	D1963, D1962	D1965, D1964	D1967, D1966
97	D1971, D1970	D1973, D1972	D1975, D1974	D1977, D1976
98	D1981, D1980	D1983, D1982	D1985, D1984	D1987, D1986
99	D1991, D1990	D1993, D1992	D1995, D1994	D1997, D1996



## 9.4 M code control during operation with multi-step speed: M9160 (FX-10GM)

M code control operations are added for a case in which operation with multi-step speed is performed in the FX-10GM.

Applicable products and versions

**Table:9.7** *Applicable products and versions*

Product model name	Applicable version
One-axis positioning unit FX-10GM	Ver. 1.10 shipped in August, 1996 or later (serial No. 68****)

Description

- Outline  
When operation with multi-step speed (cod 01 instruction) is performed while a special auxiliary relay M9160 in the FX-10GM is set to ON, the M code (with mode) can perform the following operations.
  - When an M code OFF command is not given, operation with multi-step speed is not continued but an M code OFF command is waited.
  - When an M code OFF command is set to ON, operation with multi-step speed is continued. However, when operation is located in the deceleration area, positioning for the target address of the command is performed, then a next instruction is executed.

**Use example 1:** M9160 is set to ON.

The following operation is picked up as an example.

```

N0000  Ox0, N0;
      .
      .
N0010  SET M9160;
N0011  cod01 xC f100,000 m10;
N0012  cod01 xD f200,000;
N0013  RST M9160;
      .
      .
N0020  m02(END)
    
```

In the program above, the following operation is performed.

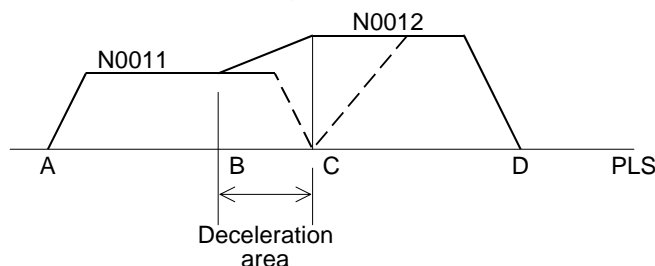

- ① When an M code OFF command is given between the points A and B, the speed is changed to the next step.
- ② When an M code OFF command is not given between the points A and C, operation is stopped at the point C and an M code OFF command is waited. When an M code OFF command is given, positioning to the point D is performed.
- ③ When an M code OFF command is given between the points B and C, operation is stopped at the point C, and positioning to the point D is immediately performed.

**Use example 2:** M9160 is set to ON.

```

N0000  Oxo, N0;
      .
      .

N0010  SET M9160;
N0011  cod01 xC f200,000 m10;
N0012  cod01 xD f200,000;
N0013  RST M9160;
      .
      .

N0020  m02(END)
    
```

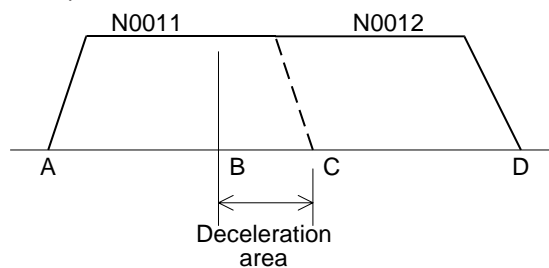

The use example 2 is similar to the use example 1.

- ① When an M code OFF command is given between the points A and B, the speed is changed to the next step.
- ② When an M code OFF command is not given between the points A and C, operation is stopped at the point C and an M code OFF command is waited. When an M code OFF command is given, positioning to the point D is performed.
- ③ When an M code OFF command is given between the points B and C, operation is stopped at the point C, and positioning to the point D is immediately performed.

**\* Caution**

In operation with multi-step speed (cod 01), operation may not be continued depending on combination of the movement quantity and the acceleration/deceleration time (parameter No. 10).

In other words, if the number of movement pulses required to change from the current operation speed to the next-step speed is not assured or if the movement period is short, operation with multi-step speed is not continued.

## 9.5 Connection with FX2N Series PC

The FX2N Series PC can be also connected.

Between the FX2N Series PC, read from and write to the buffer memory can be performed using FROM/TO instructions in the same way as the FX2/FX2C Series.

Connection with PC

- Assignment of special unit Nos. and I/O Nos. is equivalent to that in the FX2/FX2C Series. (Refer to Paragraph 1.2.2 for the FX-10GM or Paragraph 1-3-3 for the FX20GM.)
- For connection with the FX2N Series PC, a conversion cable FX2N-CNV-IF is used.

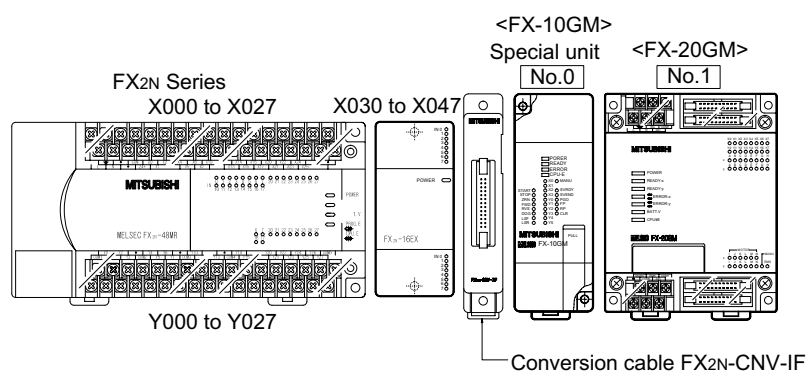

- Up to eight FX-10GM/20GM units can be connected to one FX2N Series PC.
- The cable FX2N-CNV-IF does not occupy a special unit No. nor I/O points.
- For details, refer to the FX2N Series handy manual.

## 9.6 Pulse output waveform

The following types of output pulse waveforms to a drive unit are offered. Setting by parameters is not required. Waveforms are automatically changed in accordance with the practical frequency.

① In the case of interpolation drive instruction (FX(E)-20GM)

Simultaneous 2 axes: cod 01, cod 02, cod 03, cod 31

A waveform below is obtained against the operation frequency of 1 pps to 100 kpps.

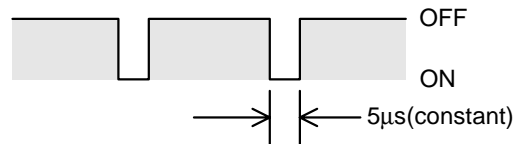

② In the case of other instructions

- When the operation frequency is 200 to 101 kpps in the FX(E)-20GM, the ON duration is fixed to 2.5 ms. As the result, the ON duration is equivalent to the OFF duration at 200 kpps.
- When the operation frequency is 100 kpps to 1 pps in the FX(E)-20GM, the ON/OFF ratio becomes 50%/50%.
- When the operation frequency is 200 kpps to 1 pps in the FX(E)-10GM, the ON/OFF ratio becomes 50%/50%.

# For parameter recording

## Positioning parameters

PARA No.	Description	X axis set value	Y axis set value
0	System of units		
1	Pulse rate		
2	Feed rate		
3	Minimum command unit		
4	Maximum speed		
5	JOG speed		
6	Bias speed		
7	Backlash compensation		
8	Acceleration time		
9	Deceleration time		
10	Interpolation time constant		
11	Pulse output format		
12	Rotation direction		
13	Zero return direction		
14	Creep speed		
15	Zero return direction		
16	Machine zero point address		
17	Zero point signal count		
18	Zero point signal count start timing		
19	DOG switch input logic		
20	Limit switch logic		
21	Error evaluation time		
22	Servo ready check		
23	Stop mode		
24	Electrical zero point address		
25	Software limit (upper)		
26	Software limit (lower)		

## I/O control parameters

PARA No.	Description	X axis set value	Y axis set value
30	Program No. specification method		
31	Head input No. for DSW time-sharing reading		
32	Head output No. for DSW time-sharing reading		
33	DSW reading interval		
34	RDY output valid		
35	RDY output No.		
36	M code external output valid		
37	M code external output No.		
38	M code OFF specification input No.		
39	Manual pulse generator		
40	Multiplying factor per pulse generated by manual pulse generator		
41	Division rate for multiplied result		
42	Head input No. for manual pulse generator enable		
43 to 49	Vacant		
50	ABS interface		
51	Head input No. for ABS		
52	Head output No. for ABS control		
53	Single-step operation		
54	Single-step mode input No.		
55	Vacant		
56	General purpose input declaration for FWD/RVS/ZRN		

## System parameters

PARA No.	Description	Value
100	Memory size	
101	File registers	
102	Battery status	
103	Battery status output No.	
104	Subtask start	
105	Subtask start input No.	
106	Subtask stop	
107	Subtask stop input No.	
108	Subtask error	
109	Subtask error output	
110	Subtask single-step/cyclic operation	
111	Subtask single-step/cyclic operation input No.	



Under no circumstances will Mitsubishi Electric be liable or responsible for any consequential damage that may arise as a result of the installation, use and/or programming of the products associated with this manual. All examples and diagrams shown in this manual are intended as an aid to understanding the text, not to guarantee operation. Mitsubishi Electric will accept no responsibility for actual use of the product based on these illustrative examples.

Owing to the very great variety of possible applications, users must satisfy themselves as to the suitability of each specific application.